



BRAKE SYSTEMS FOR CONTAINER CRANES
BRAKING UNLIMITED

Made in Germany

BRAKE SYSTEMS FOR CONTAINER CRANES

BRAKING UNLIMITED

Content

Chapter A	Thruster Disc Brakes	page 3 - 17
Chapter B	Hydraulic Disc Brakes	page 19 - 31
Chapter C	Electromagnetic Disc Brakes	page 33 - 64
Chapter D	Drum Brakes, Band Brakes	page 65 - 81
Chapter E	Couplings, Hubs, Discs, Drums	page 83 - 102
Chapter F	Monitoring Systems, Control Systems	page 103 - 117
Chapter G	Storm Brakes	page 119 - 131
Chapter H	Buffers	page 133 - 140

Disc Brake SB 28.3 / SB 23.3 with BUEL®



PINTSCH BUBENZER
is certified according to
DIN EN ISO 9001:2015

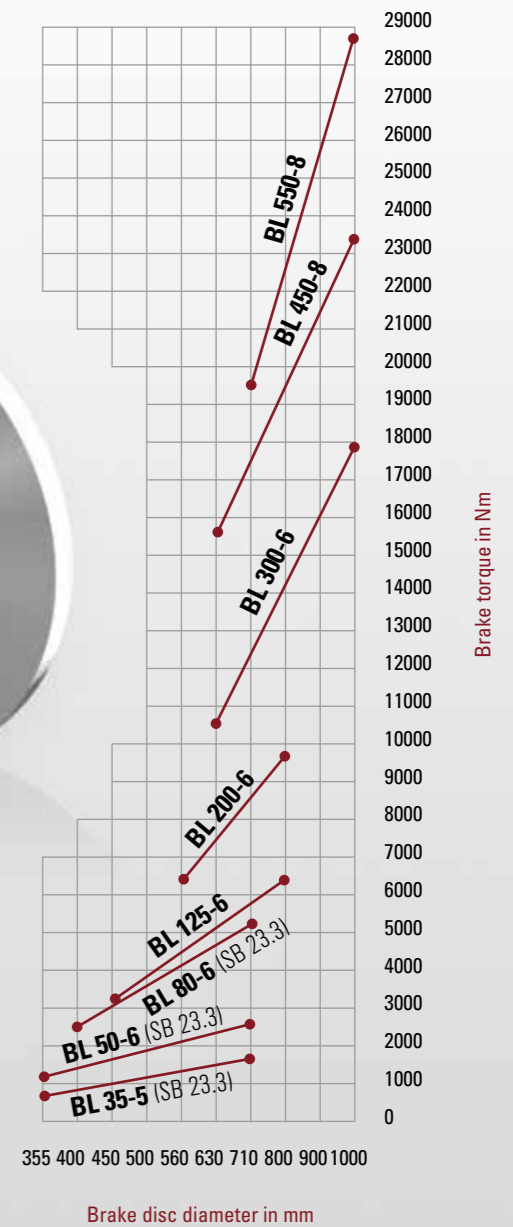

Easy Maintenance



High Performance



Reliable



Robust Design



Self-Centering

A

Description SB 28.3 / SB 23.3 with BUEL®



Main Features

- Limit switch release control
- Manual release lever with or without lock
- Self-centering of brake arms by cam disc and roller
- Automatic wear compensator
- Sintered linings for high friction speeds
- Continuously adjustable brake spring with torque scale and wear bushing enclosed in a spring tube
- Stainless steel pins and spindles
- W-execution (special anti-corrosion protection)
- Maintenance-free bushings in all hinge points
- Symmetric design
- Parallel air gap when brake is released (no tipping of the brake shoes)

Options

- Limit switch wear control
- Limit switch manual release
- Monitoring systems (e.g. VSR/CMB)
- Brake disc with hub or coupling

BUEL® Thrusters, Technical Data

Thruster Type	Power (W)	Curr. (A) at 400 V	Weight (kg)
BL 35-5	350	0,6	16
BL 50-6	450	0,7	16
BL 80-6	600	1,3	21
BL 125-6	650	1,4	24
BL 200-6	800	1,5	24
BL 300-6	900	1,6	33
BL 450-8	1200	2,0	33
BL 550-8	1250	2,1	33

Protection: max. 1.5 times of nominal current

Ordering Example

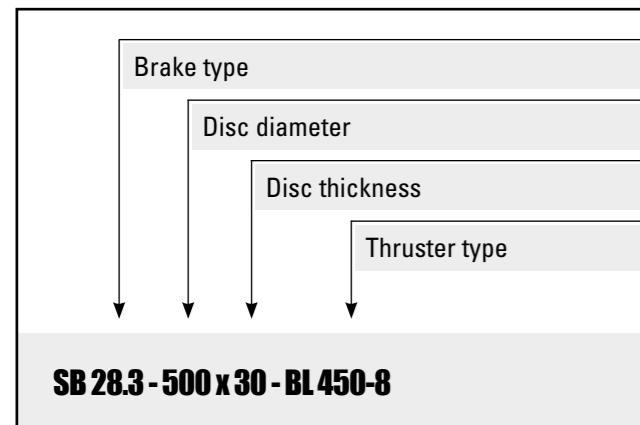

Disc Brake SB 28.3 with BUEL®

Dimensions and technical data



Rev. 03-17

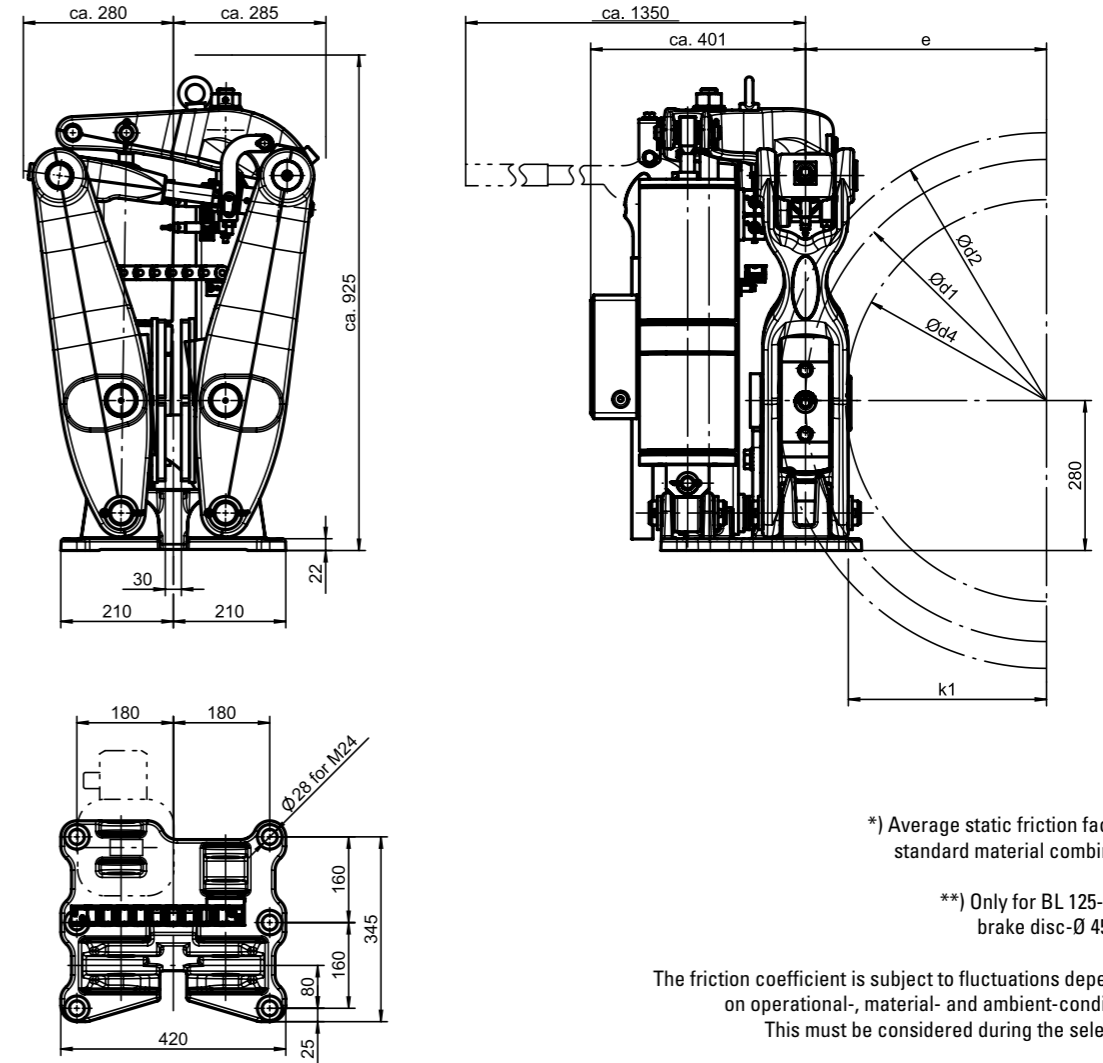

*) Average static friction factor of standard material combination

***) Only for BL 125-6 with brake disc-Ø 450 mm

The friction coefficient is subject to fluctuations depending on operational-, material- and ambient-conditions! This must be considered during the selection!

All dimensions in mm
Alterations reserved without notice

For crane brake layout use safety factors documented in the FEM 1.001, Section 1

Disc-Ø d2	Friction-Ø d1	Max. hub-Ø d4	Thruster type		BL 125-6 (Weight: 24 kg)			BL 200-6 (Weight: 24 kg)			BL 300-6 (Weight: 33 kg)			BL 450-8 (Weight: 33 kg)			BL 550-8 (Weight: 33 kg)		
			e	k1	*M _{Bmax} (Nm) at μ = 0,4	*M _{Bmin} (Nm) at μ = 0,4	*M _{Bmin} (% from M _{Bmax})	*M _{Bmax} (Nm) at μ = 0,4	*M _{Bmin} (Nm) at μ = 0,4	*M _{Bmin} (% from M _{Bmax})	*M _{Bmax} (Nm) at μ = 0,4	*M _{Bmin} (Nm) at μ = 0,4	*M _{Bmin} (% from M _{Bmax})	*M _{Bmax} (Nm) at μ = 0,4	*M _{Bmin} (Nm) at μ = 0,4	*M _{Bmin} (% from M _{Bmax})			
450	350	175 (200***)	175	95	3150	1575	50												
500	400	225	200	120	3600	1800	50												
560	460	285	230	150	4140	2070	50	6440	3220	50									
630	530	355	265	185	4770	2385	50	7420	3710	50	10600	5300	55						
710	610	435	305	225	5490	2745	50	8540	4270	50	12200	6100	55	15860	7930	50	19520	9760	50
800	700	525	350	270	6300	3150	50	9800	4900	50	14000	7000	55	18200	9100	50	22400	11200	50
900	800	625	400	320							16000	8000	55	20800	10400	50	25600	12800	50
1000	900	725	450	370							18000	9000	55	23400	11700	50	28800	14400	50



Please Note

We supply a detailed operating manual with every order. Nevertheless, we would point out that brakes are only as safe as the servicing and maintenance performed while they are in operation. The guarantee for the correct functioning of our brakes is only valid if the user adheres to the German DIN standard 15434 part 2 (drum and disc brakes, servicing and maintenance in operation), or to comparable standards in his own country.



PINTSCH BUBENZER Service

This includes the verification of the brake selection, if required. A detailed questionnaire is provided for this purpose. Installation and commissioning on-site by PINTSCH BUBENZER service engineers is possible. Drawings as DWG/DXF files for your engineering department are available upon request.

Disc Brake SB 23.3 with BUEL®

Dimensions and technical data



Rev. 03-17

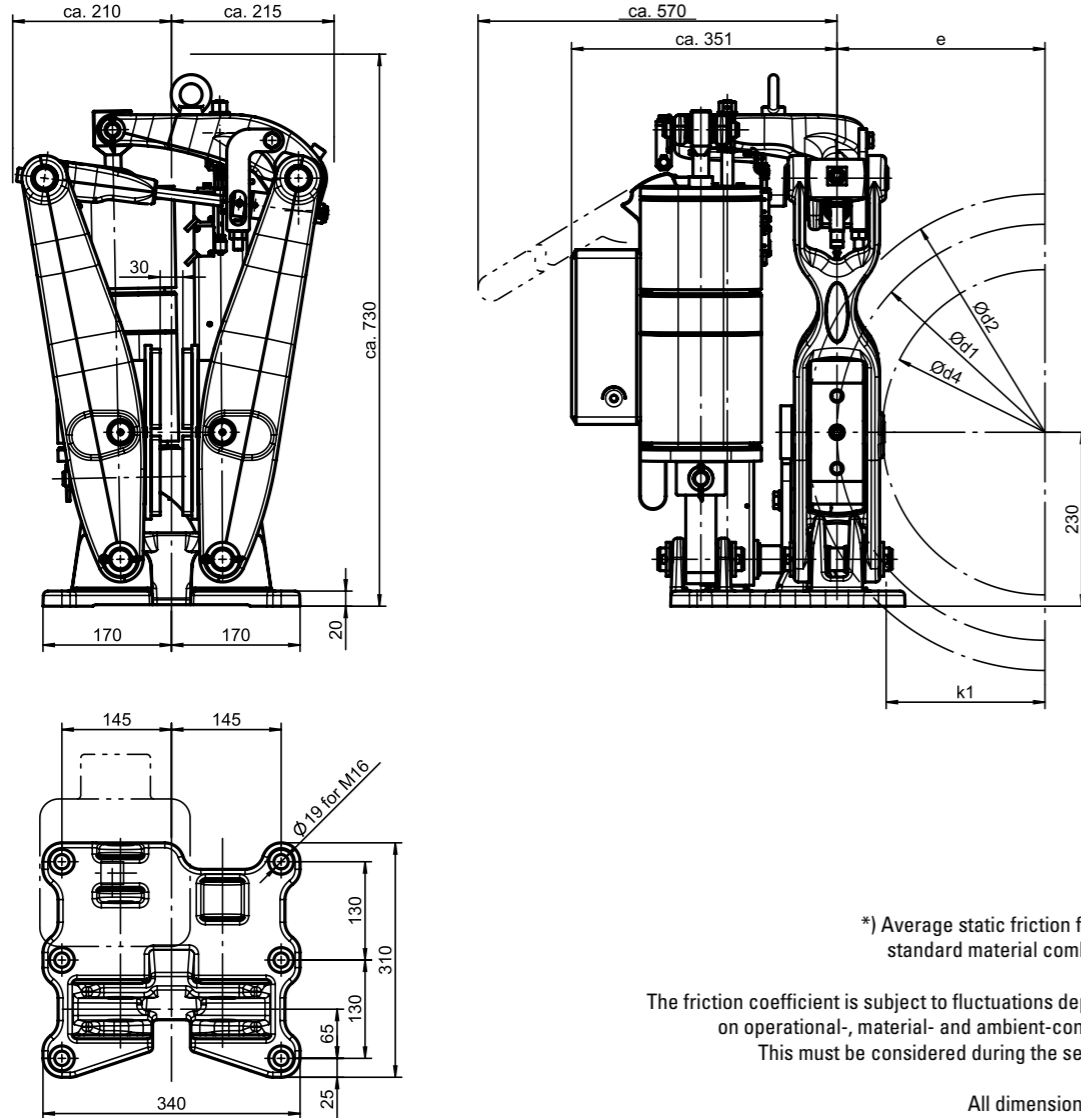

*) Average static friction factor of standard material combination

The friction coefficient is subject to fluctuations depending on operational-, material- and ambient-conditions! This must be considered during the selection!

All dimensions in mm
Alterations reserved without notice

For crane brake layout use safety factors documented in the FEM 1.001, Section 1

Weight without thruster: ca. 99 kg			Thruster type	BL 35-5 (Weight: 16 kg)			BL 50-6 (Weight: 16 kg)			BL 80-6 (Weight: 21 kg)			
Disc-Ø d2	Friction-Ø d1	Max. hub-Ø d4	Contact force in N	6845			10750			20500			
e	k1	*M _{Bmax.} (Nm) at μ = 0,4	*M _{Bmin.} (Nm) at μ = 0,4	*M _{Bmin.} (% from M _{Bmax.})	*M _{Bmax.} (Nm) at μ = 0,4	*M _{Bmin.} (Nm) at μ = 0,4	*M _{Bmin.} (% from M _{Bmax.})	*M _{Bmax.} (Nm) at μ = 0,4	*M _{Bmin.} (Nm) at μ = 0,4	*M _{Bmin.} (% from M _{Bmax.})	*M _{Bmax.} (Nm) at μ = 0,4	*M _{Bmin.} (Nm) at μ = 0,4	*M _{Bmin.} (% from M _{Bmax.})
355	275	145	137,5	72,5	755	378	50						
400	320	190	160	95	875	438	50	1375	825	60	2625	1313	50
450	370	240	185	120	1015	508	50	1590	954	60	3035	1518	50
500	420	290	210	145	1150	575	50	1805	1083	60	3445	1723	50
560	480	350	240	175	1315	658	50	2065	1239	60	3935	1968	50
630	550	420	275	210	1505	753	50	2365	1419	60	4510	2255	50
710	630	500	315	250	1725	863	50	2710	1626	60	5165	2583	50

Disc Brake SB 16 with BUEL®



PINTSCH BUBENZER
is certified according to
DIN EN ISO 9001:2015

Brake disc diameter (mm)	BL 22-5 (Nm)	BL 30-5 (Nm)	BL 35-5 (Nm)
250	~200	~250	~300
280	~220	~280	~330
315	~250	~320	~380
355	~280	~360	~430
400	~320	~400	~480
450	~360	~440	~530
500	~400	~480	~580

- Easy Maintenance
- High Performance
- Reliable
- Robust Design
- Self-Centering

Description SB 16 with BUEL®



Main Features

- Limit switch release control
- Manual release lever with or without lock
- Self-centering of brake arms by cam disc and roller
- Automatic wear compensator
- Sintered linings for high friction speeds
- Organic, non-asbestos linings for low friction speeds
- Continuously adjustable brake spring with torque scale and wear bushing enclosed in a spring tube
- Stainless steel pins and spindles
- Maintenance-free bushings in all hinge points
- Right or left-hand design
- W-execution (special anti-corrosion protection)

Options

- Limit switch wear control
- Limit switch manual release
- Monitoring systems (e.g. VSR/CMB)
- Brake disc with hub or coupling

BUEL® Thrusters, Technical Data

Thruster Type	Power (W)	Curr. (A) at 400 V	Weight (kg)
BL 22-5	150	0,4	11
BL 30-5	160	0,4	13
BL 35-5	350	0,6	16

Protection: max. 1.5 times of nominal current

Ordering Example

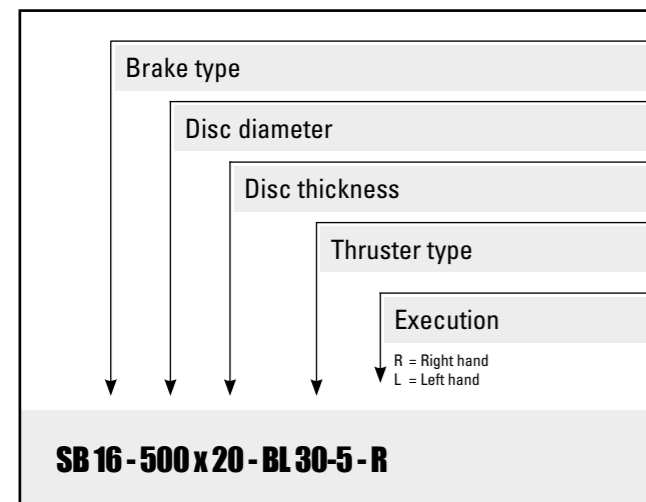

SB 16 - 500 x 20 - BL 30-5 - R

Please Note

We supply a detailed operating manual with every order. Nevertheless, we would point out that brakes are only as safe as the servicing and maintenance performed while they are in operation. The guarantee for the correct functioning of our brakes is only valid if the user adheres to the German DIN standard 15434 part 2 (drum and disc brakes, servicing and maintenance in operation), or to comparable standards in his own country.

PINTSCH BUBENZER Service

This includes the verification of the brake selection, if required. A detailed questionnaire is provided for this purpose. Installation and commissioning on-site by PINTSCH BUBENZER service engineers is possible. Drawings as DWG/DXF files for your engineering department are available upon request.

Disc Brake SB 16 with BUEL®

Dimensions and technical data



Rev. 02-17

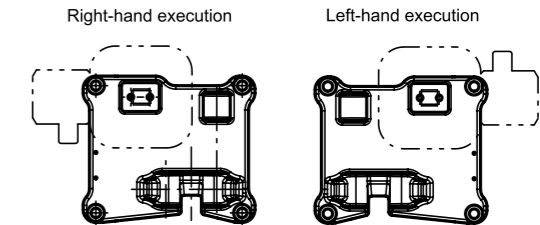
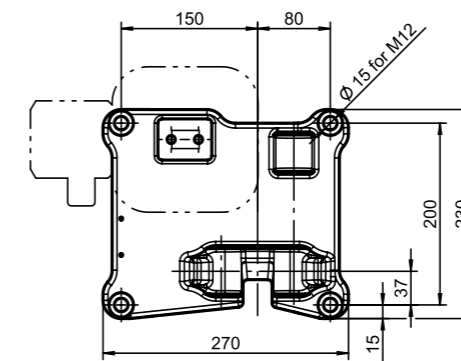
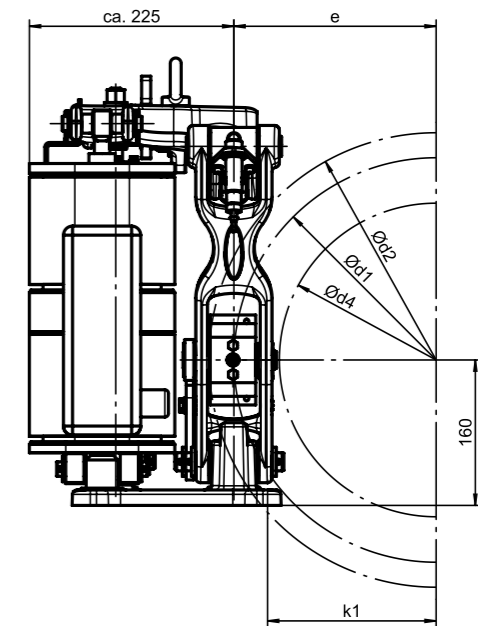
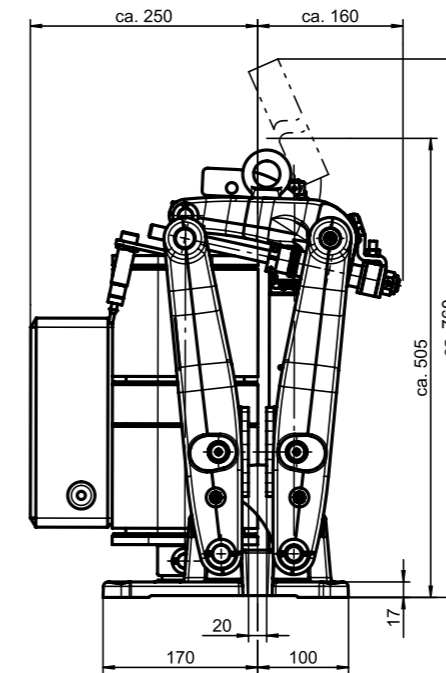

*) Average static friction factor of standard material combination

All dimensions in mm
Alterations reserved without notice

The friction coefficient is subject to fluctuations depending on operational-, material- and ambient-conditions!
This must be considered during the selection!

For crane brake layout use safety factors documented in the FEM 1.001, Section 1

Weight without thruster: ca. 37 kg			Thruster type		BL 22-5 (Weight: 11 kg)			BL 30-5 (Weight: 13 kg)			BL 35-5 (Weight: 16 kg)		
Disc-Ø d2	Friction-Ø d1	Max. hub-Ø d4	Contact force in N		2610			3400			5000 (on request)		
			e	k1	*M _{Brmax.} (Nm) at μ = 0,4	*M _{Brmin.} (Nm) at μ = 0,4	*M _{Brmin.} (% from M _{Brmax.})	*M _{Brmax.} (Nm) at μ = 0,4	*M _{Brmin.} (Nm) at μ = 0,4	*M _{Brmin.} (% from M _{Brmax.})	*M _{Brmax.} (Nm) at μ = 0,4	*M _{Brmin.} (Nm) at μ = 0,4	*M _{Brmin.} (% from M _{Brmax.})
250	195	95	97,5	60,5	205	103	50	265	133	50	390	195	50
280	225	125	112,5	75,5	235	118	50	305	153	50	450	225	50
315	260	160	130	93	270	135	50	355	178	50	520	260	50
355	300	200	150	113	315	158	50	410	205	50	600	300	50
400	345	245	172,5	135,5	360	180	50	470	235	50	690	345	50
450	395	295	197,5	160,5	410	205	50	535	268	50	790	395	50
500	445	345	222,5	185,5	465	233	50	605	303	50	890	445	50

Description SB 8



Main Features

- Compact dimensions
- Ideal for belt conveyors in combination with long stroke thrusters
- Sintered linings for high friction speeds
- Organic, non-asbestos linings for low friction speeds
- Continuously adjustable brake spring with torque scale and wear bushing enclosed in a spring tube
- Stainless steel pins and spindles
- Maintenance-free bushings in all hinge points
- Right or left-hand design

Options

- Automatic wear compensator
- Limit switch release control
- Limit switch wear control
- Limit switch manual release
- Manual release lever with or without lock
- Monitoring systems (e.g. VSR/CMB)
- Brake discs with hubs or couplings

Thrusters, Technical Data

Thruster Type	Power (W)	Curr. (A) at 400 V	Weight (kg)
BL 22-5	150	0,4	11
BL 30-5	160	0,4	13
BL 50-6	450	0,7	16
BL 80-6	600	1,3	21
BL 125-6	650	1,4	24
BL 200-6	800	1,5	24

Protection: max. 1.5 times of nominal current

Ordering Example

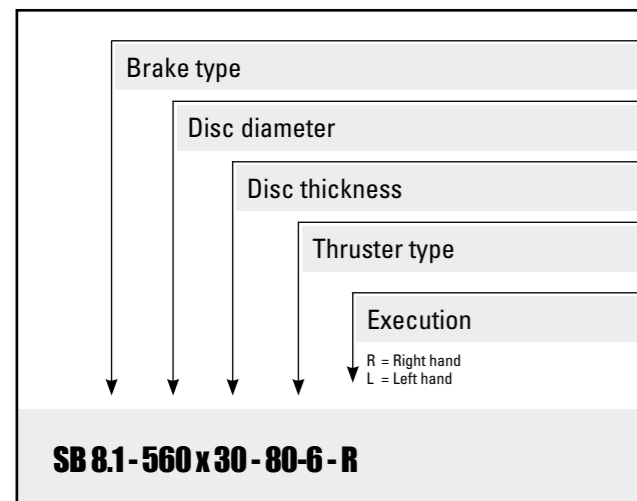

Disc Brake SB 8.11

Dimensions and technical data



Rev. 01-17

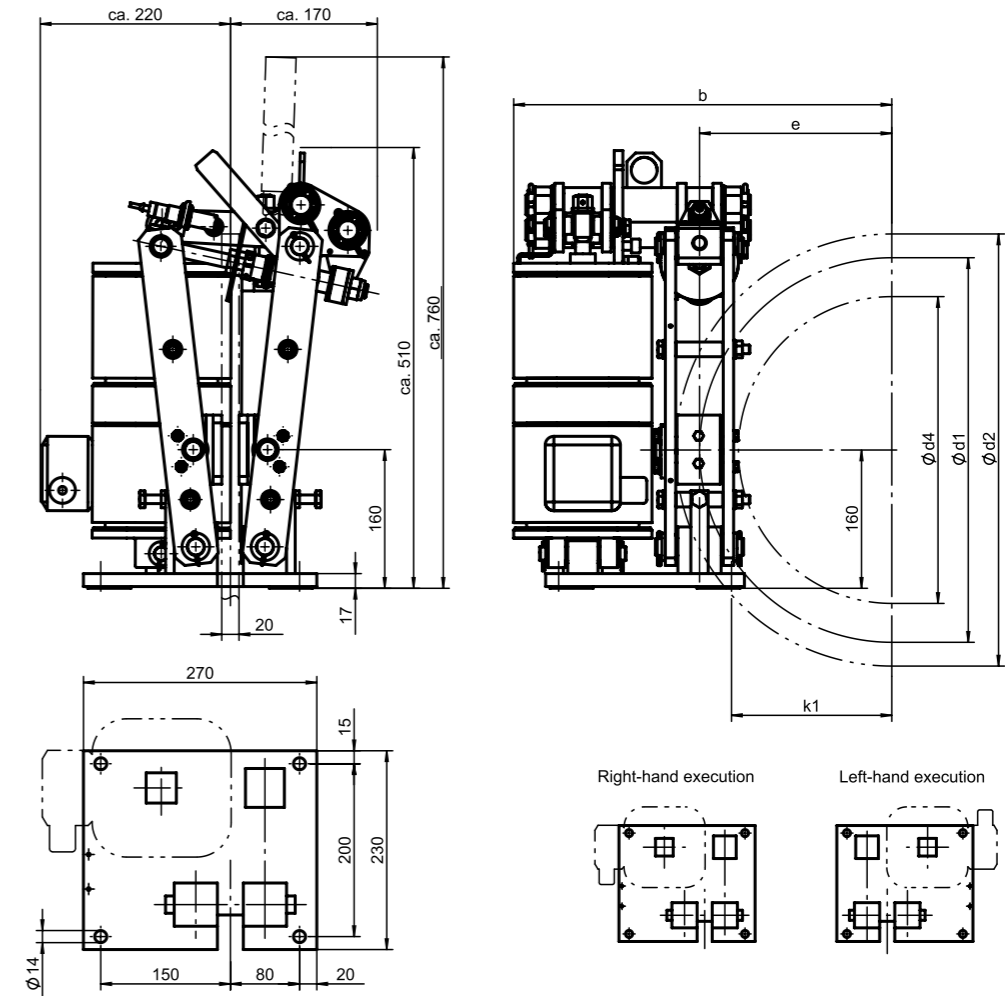

For crane brake layout use safety factors documented in the FEM 1.001, Section 1

The friction coefficient is subject to fluctuations depending on operational-, material- and ambient-conditions! This must be considered during the selection!

*) Average static friction factor of standard material combination

All dimensions in mm
Alterations reserved without notice

Weight without thruster: ca. 37 kg			Thruster type			BL 22-5 (Weight: 11 kg)			BL 30-5 (Weight: 13 kg)		
Disc Ø d ₂	Friction Ø d ₁	Max. hub-Ø d ₄	Contact force in N			2500			3400		
			b _{max.}	e	k ₁	*M _{Brmax.} (Nm) at μ = 0,4	*M _{Brmin.} (Nm) at μ = 0,4	*M _{Brmin.} (% from M _{Brmax.})	*M _{Brmax.} (Nm) at μ = 0,4	*M _{Brmin.} (Nm) at μ = 0,4	*M _{Brmin.} (% from M _{Brmax.})
250	195	105	335	97,5	60,5	195	107	55	265	133	50
280	225	135	350	112,5	75,5	225	124	55	305	153	50
315	260	170	368	130	93	260	143	55	355	178	50
355	300	210	388	150	113	300	165	55	410	205	50
400	345	255	410	172,5	135,5	345	190	55	470	235	50
450	395	305	435	197,5	160,5	395	217	55	535	268	50
500	445	355	460	222,5	185,5	445	245	55	605	303	50



Please Note

We supply a detailed operating manual with every order. Nevertheless, we would point out that brakes are only as safe as the servicing and maintenance performed while they are in operation. The guarantee for the correct functioning of our brakes is only valid if the user adheres to the German DIN standard 15434 part 2 (drum and disc brakes, servicing and maintenance in operation), or to comparable standards in his own country.



PINTSCH BUBENZER Service

This includes the verification of the brake selection, if required. A detailed questionnaire is provided for this purpose. Installation and commissioning on-site by PINTSCH BUBENZER service engineers is possible. Drawings as DWG/DXF files for your engineering department are available upon request.

Disc Brake SB 8.1

Dimensions and technical data



Rev. 01-17

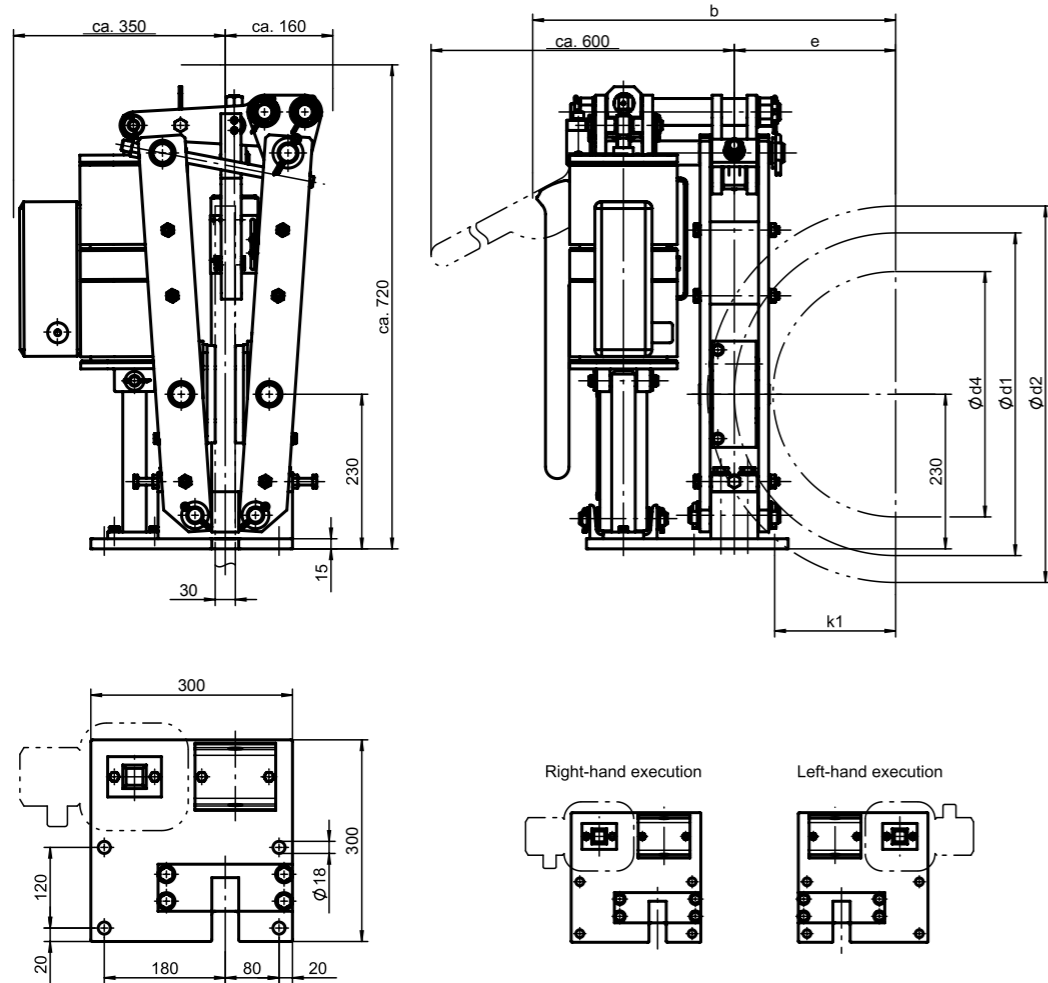

For crane brake layout use safety factors documented in the FEM 1.001, Section 1

*) Average static friction factor of standard material combination

The friction coefficient is subject to fluctuations depending on operational-, material- and ambient-conditions! This must be considered during the selection!

All dimensions in mm
Alterations reserved without notice

Weight without thruster: ca. 83 kg			Thruster type			BL 30-5 (Weight: 13 kg)			BL 50-6 (Weight: 16 kg)			BL 80-6 (Weight: 21 kg)		
Disc Ø d2	Friction Ø d1	Max. hub-Ø d4	Contact force in N			6300			11850			16930		
			b _{max.}	e	k ₁	*M _{Brmax.} (Nm) at μ = 0,4	*M _{Brmin.} (Nm) at μ = 0,4	*M _{Brmin.} (% from M _{Brmax.})	*M _{Brmax.} (Nm) at μ = 0,4	*M _{Brmin.} (Nm) at μ = 0,4	*M _{Brmin.} (% from M _{Brmax.})	*M _{Brmax.} (Nm) at μ = 0,4	*M _{Brmin.} (Nm) at μ = 0,4	*M _{Brmin.} (% from M _{Brmax.})
355	275	160	438	137,5	77,5	695	348	50	1305	653	50	1860	930	50
400	320	205	460	160	100	805	403	50	1515	758	50	2165	1083	50
450	370	255	485	185	125	930	465	50	1755	878	50	2505	1253	50
500	420	305	510	210	150	1060	530	50	1990	995	50	2845	1423	50
560	480	365	540	240	180	1210	605	50	2275	1138	50	3250	1625	50

Disc Brake SB 8.2

Dimensions and technical data



Rev. 01-17

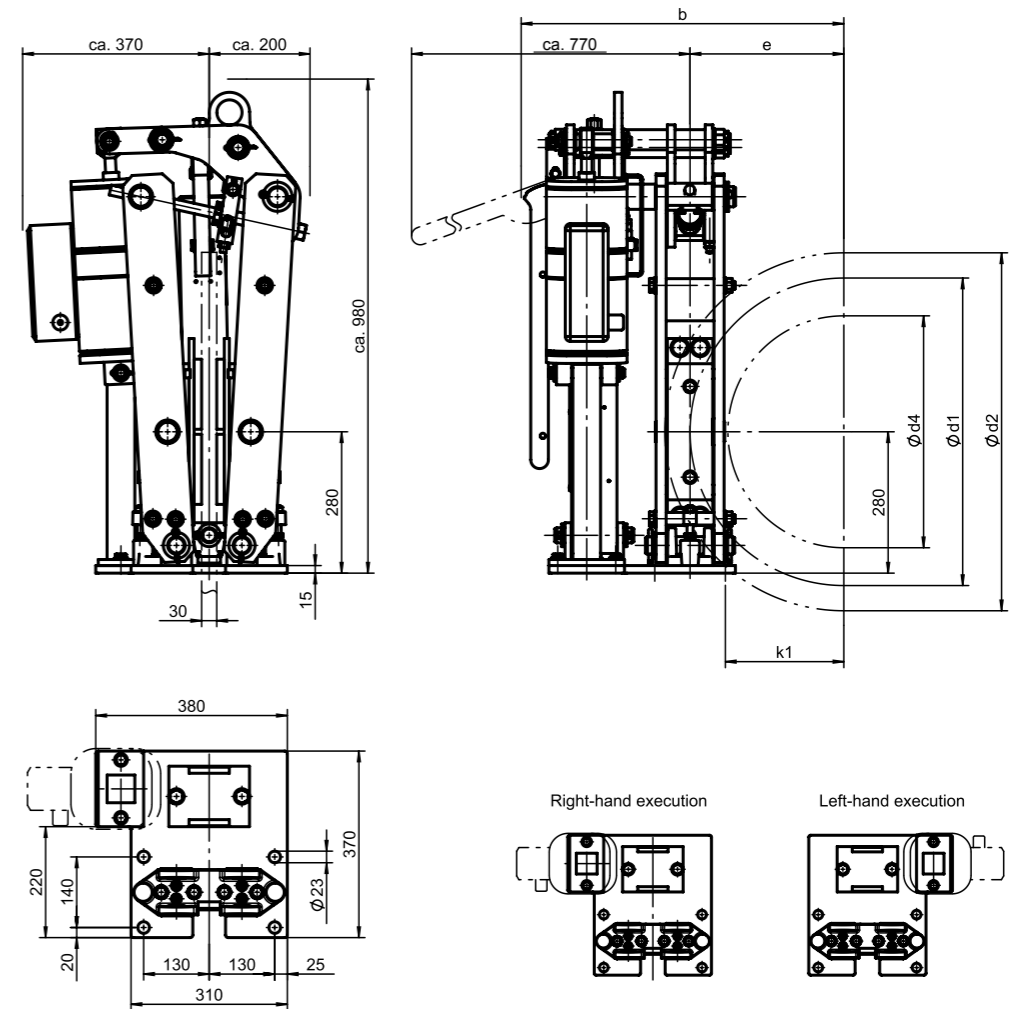

For crane brake layout use safety factors documented in the FEM 1.001, Section 1

*) Average static friction factor of standard material combination

The friction coefficient is subject to fluctuations depending on operational-, material- and ambient-conditions! This must be considered during the selection!

All dimensions in mm
Alterations reserved without notice

Weight without thruster: ca. 180 kg			Thruster type			BL 50-6 (Weight: 16 kg)			BL 80-6 (Weight: 21 kg)			BL 125-6 (Weight: 24 kg)		
Disc Ø d2	Friction Ø d1	Max. hub-Ø d4	Contact force in N			11680			25200			33500		
			b _{max.}	e	k ₁	*M _{Brmax.} (Nm) at μ = 0,4	*M _{Brmin.} (Nm) at μ = 0,4	*M _{Brmin.} (% from M _{Brmax.})	*M _{Brmax.} (Nm) at μ = 0,4	*M _{Brmin.} (Nm) at μ = 0,4	*M _{Brmin.} (% from M _{Brmax.})	*M _{Brmax.} (Nm) at μ = 0,4	*M _{Brmin.} (Nm) at μ = 0,4	*M _{Brmin.} (% from M _{Brmax.})
450	350	200	510	175	105	1635	818	50	3530	2118	60	4690	2345	50
500	400	250	535	200	130	1870	935	50	4030	2418	60	5360	2680	50
560	460	310	565	230	170	2150	1075	50	4635	2781	60	6165	3083	50
630	530	380	600	265	195	2475	1238	50	5340	3204	60	7100	3550	50
710	610	460	640	305	235	2850	1425	50	6150	3690	60	8175	4088	50



Disc Brake SB 8.3

Dimensions and technical data



Rev. 01-17

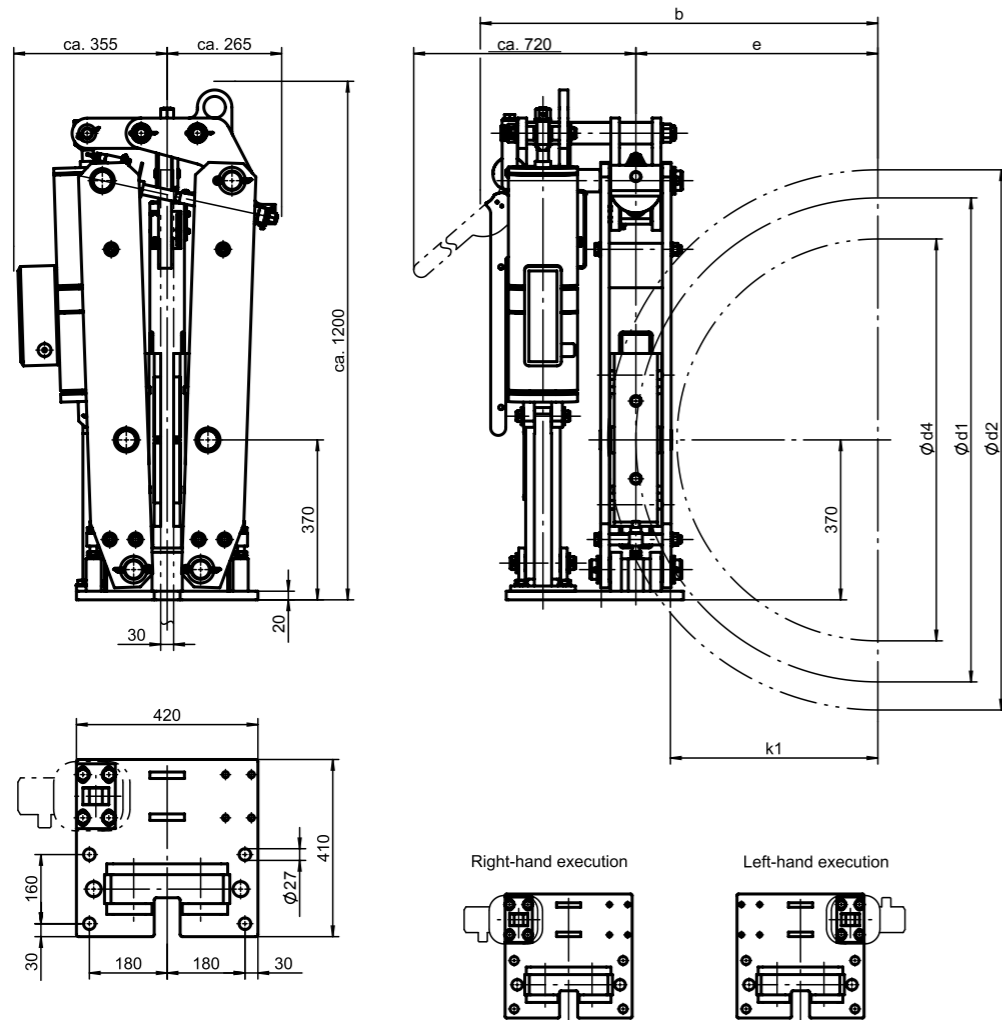

For crane brake layout use safety factors documented in the FEM 1.001, Section 1

The friction coefficient is subject to fluctuations depending on operational-, material- and ambient-conditions! This must be considered during the selection!

*) Average static friction factor of standard material combination

All dimensions in mm
Alterations reserved without notice

Weight without thruster: ca. 290 kg			Thruster type			BL 125-6 (Weight: 24 kg)			BL 200-6 (Weight: 24 kg)		
Disc Ø d ₂	Friction Ø d ₁	Max. hub-Ø d ₄	Contact force in N			31810			45760		
			b _{max.}	e	k ₁	*M _{Brmax.} (Nm) at μ = 0,4	*M _{Brmin.} (Nm) at μ = 0,4	*M _{Brmin.} (% from M _{Brmax.})	*M _{Brmax.} (Nm) at μ = 0,4	*M _{Brmin.} (Nm) at μ = 0,4	*M _{Brmin.} (% from M _{Brmax.})
630	500	310	610	250	170	6360	3180	50	9150	4575	50
710	580	390	650	290	210	7380	3690	50	10615	5308	50
800	670	480	695	335	255	8525	4263	50	12265	6133	50
900	770	580	745	385	305	9795	4898	50	14095	7048	50
1000	870	680	795	435	355	11070	5535	50	15925	7963	50
1250	1120	930	920	560	480	14250	7125	50	20500	10250	50

Disc Brake SB 22

Dimensions and technical data



Rev. 01-17

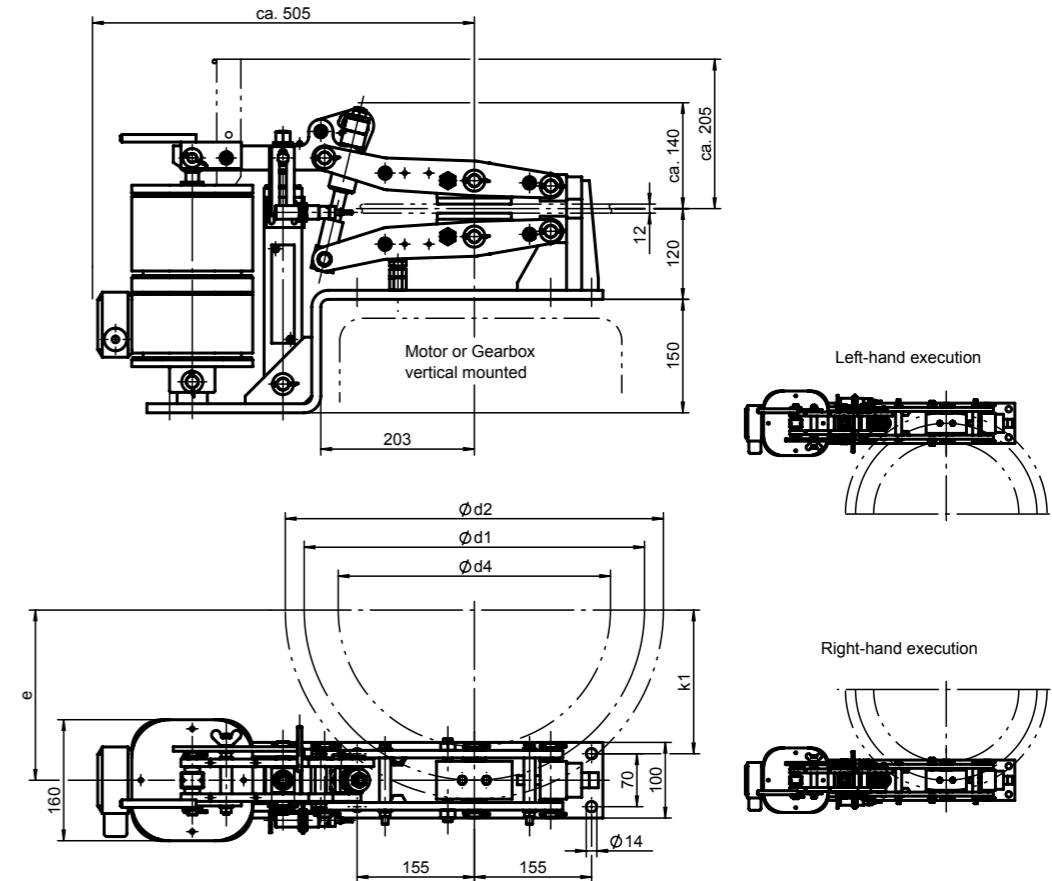

For crane brake layout use safety factors documented in the FEM 1.001, Section 1

The friction coefficient is subject to fluctuations depending on operational-, material- and ambient-conditions! This must be considered during the selection!

*) Average static friction factor of standard material combination

All dimensions in mm
Alterations reserved without notice

Weight without thruster: ca. 25 kg			Thruster type		BL 22-5 (Weight: 11 kg)		
Disc Ø d ₂	Friction Ø d ₁	Max. hub-Ø d ₄	Contact force in N		3140		
			e	k ₁	*M _{Brmax.} (Nm) at μ = 0,4	*M _{Brmin.} (Nm) at μ = 0,4	*M _{Brmin.} (% from M _{Brmax.})
200	150	60	75	40	190	114	60
225	175	85	88	53	220	132	60
250	200	110	100	65	250	150	60
280	230	140	115	80	290	174	60
315	265	175	133	98	335	201	60
355	305	215	153	118	385	231	60
400	350	260	175	140	440	264	60
450	400	310	200	165	500	300	60
500	450	360	225	190	565	339	60



Notes

Hydraulic Caliper Disc Brakes SF Series

B

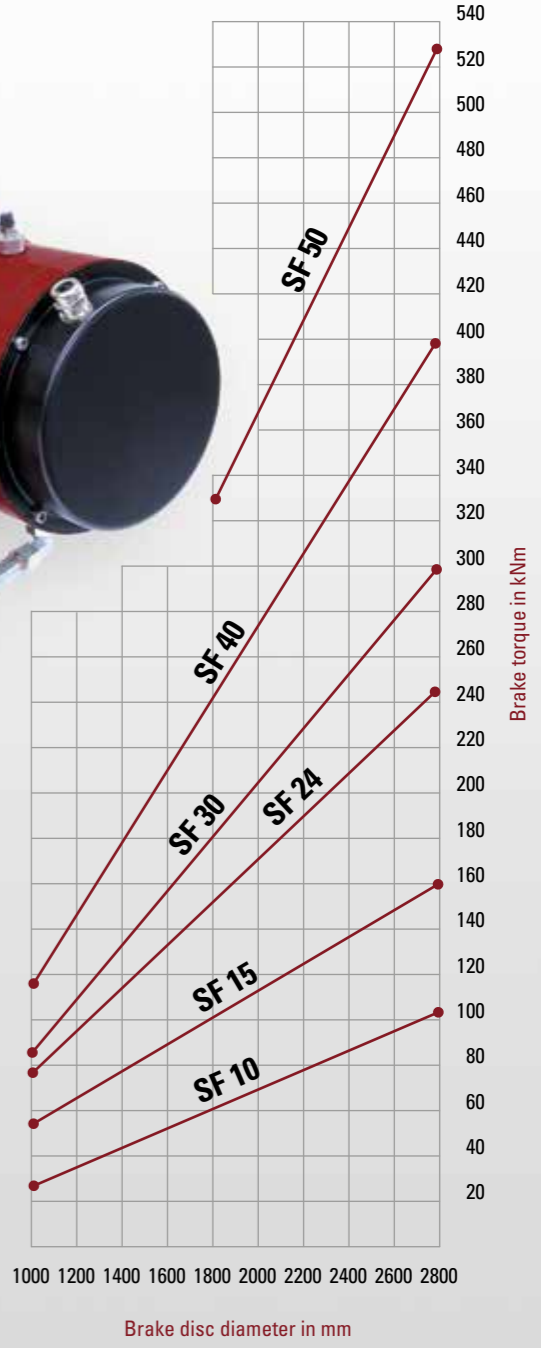

PINTSCH BUBENZER
is certified according to
DIN EN ISO 9001:2015



Easy Maintenance



High Performance



Reliable



Robust Design

Description SF



Main Features

- Two identical caliper halves, ready for operation, with spring packs set to nominal force and limit switch release control
- Up to 2 mm air gap between brake pad and disc
- Easy, manual pad wear compensation
- Sintered linings

Applications

- The high capacity of these brakes makes them particularly suitable as secondary emergency brakes on hoist gears and on downhill conveyor
- Other applications are possible in material handling, requiring power and compact design in either direction of rotation, particularly in replacing band brakes
- Brakes for use in high duty cycle applications are to be specifically indicated prior to the technical selection procedure**

Options

- Limit switch wear control
- Complete piped supports for one or more calipers
- Hydraulic power units
- Special seals for flameproof fluids
- Cleaning pads
- Brake discs
- CMB contact force measurement

Operating Restrictions

Brakes of this range are tested both mechanically and hydraulically and are set to nominal force. This setting can only be changed by the manufacturer. Operating conditions other than described in this brochure require the manufacturer's approval and may influence the function of the caliper and its components

Disc Brake SF

Dimensions and technical data



Rev. 12-16

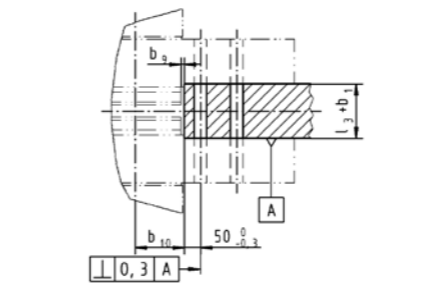
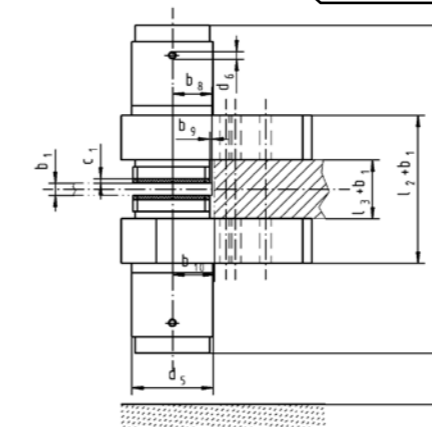
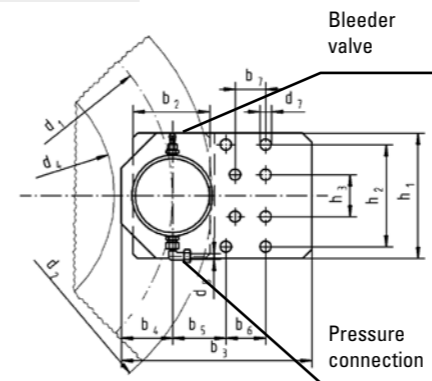

*) Average friction factor of standard material combination

All dimensions in mm
Alterations reserved without notice

Brake torque M_{Br} in Nm = F_A (kN) x μ x d_1 (mm)

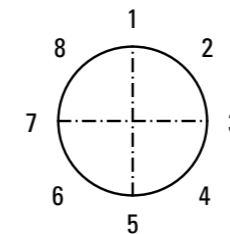

Please indicate required mounting position

Type SF	10	15	24	30	40
b2	165	165	195	280	300
b3	410	410	480	640	720
b4	110	110	130	155	175
b5	115	115	130	200	220
b6	85	85	100	110	125
b7	60	60	70	110	125
b8	85	85	100	140	160
b9	5	5	5	5	10
b10	90	90	105	150	170
c1	10	10	10	10	10
d5	175	175	225	280	310
d6	G1/2"	G1/2"	G1/2"	G1/2"	G1/2"
d7	25	25	31	38	50
d8	12	12	12	12	12
h1	270	270	300	400	480
h2	220	220	230	300	375
h3	90	90	70	100	125
l1	655	680	815	945	985
l2	300	300	350	402	506
l3	100	100	110	130	110
l4min	110	110	130	180	200
Bolt \emptyset	M24	M24	M30	M36	M48
Bolt material	10.9	10.9	10.9	10.9	10.9
Tightening torque Nm	1050	1050	2100	3500	6400
Contact force F_A kN	100	150	240	300	400
Op. pressure bar	140	180	180	210	210
Max. pressure bar	200	200	200	240	240
Release stroke mm	2	2	2	2	2
Oil volume l	0,023	0,023	0,035	0,050	0,052
Pad surface cm ²	398	398	533	1050	1360
Theor. friction μ^*	0,40	0,40	0,40	0,40	0,40
Weight (kg)	200	210	368	750	1180

Data per caliper half

	SF10	SF15	SF24	SF30	SF40
$d_1 = d_2$	170 mm	170 mm	200 mm	290 mm	320 mm
$d_4 = d_2$	420 mm	420 mm	490 mm	620 mm	700 mm

d_2 = Brake disc diameter in mm
 d_1 = Friction diameter in mm
 d_4 = Max. permissible drum or hub diameter in mm
 b_1 = Disc thickness in mm (min. 30)

Please Note

We supply a detailed operating manual with every order. Nevertheless, we would point out that brakes are only as safe as the servicing and maintenance performed while they are in operation. The guarantee for the correct functioning of our brakes is only valid if the user adheres to the German DIN standard 15434 part 2 (drum and disc brakes, servicing and maintenance in operation), or to comparable standards in his own country.

PINTSCH BUBENZER Service

This includes the verification of the brake selection, if required. A detailed questionnaire is provided for this purpose. Installation and commissioning on-site by PINTSCH BUBENZER service engineers is possible. Drawings as DWG/DXF files for your engineering department are available upon request.

Disc Brake SF 50

Dimensions and technical data



Rev. 12-16

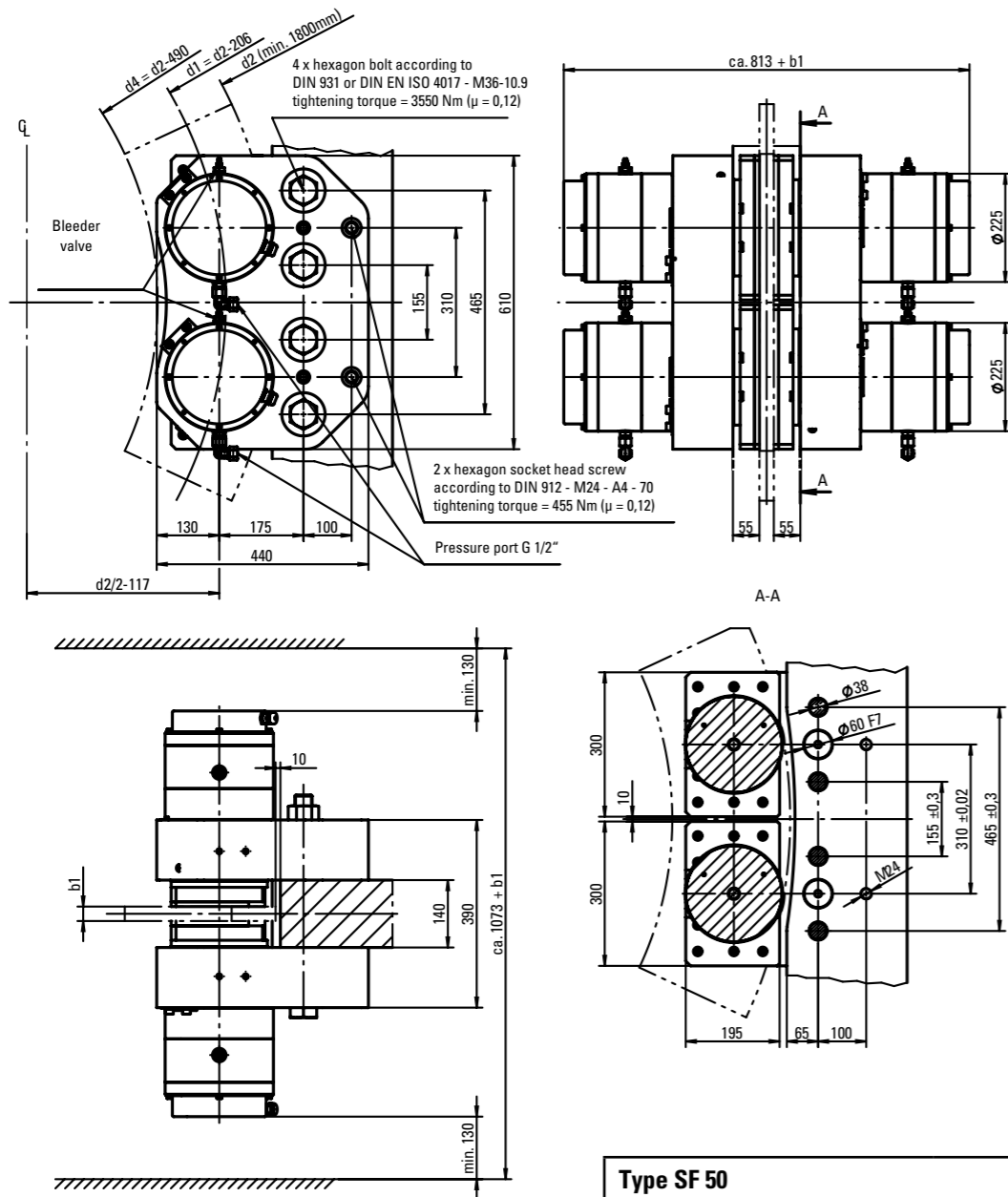

Brake torque M_{Br} in Nm = F_A (kN) x μ x d_1 (mm)

*) Theor. friction factor of standard material combination

All dimensions in mm
Alterations reserved without notice

Type SF 50		
Contact force F_A	kN	510
Operating pressure p	bar	200
Max. pressure p_{max}	bar	220
Release stroke	mm	2
Oil volume	l	0,07
Pad surface	cm ²	1040
Theor. friction factor	μ^*	0,40
Weight (without bracket)	kg	ca. 730
d_2 = Brake disc diameter in mm d_1 = Friction diameter in mm d_4 = Max. permissible drum or hub diameter in mm b_1 = Brake disc thickness in mm (min. 30)		

Disc Brake SF

Hydraulic power unit for one or more calipers



Rev. 12-06

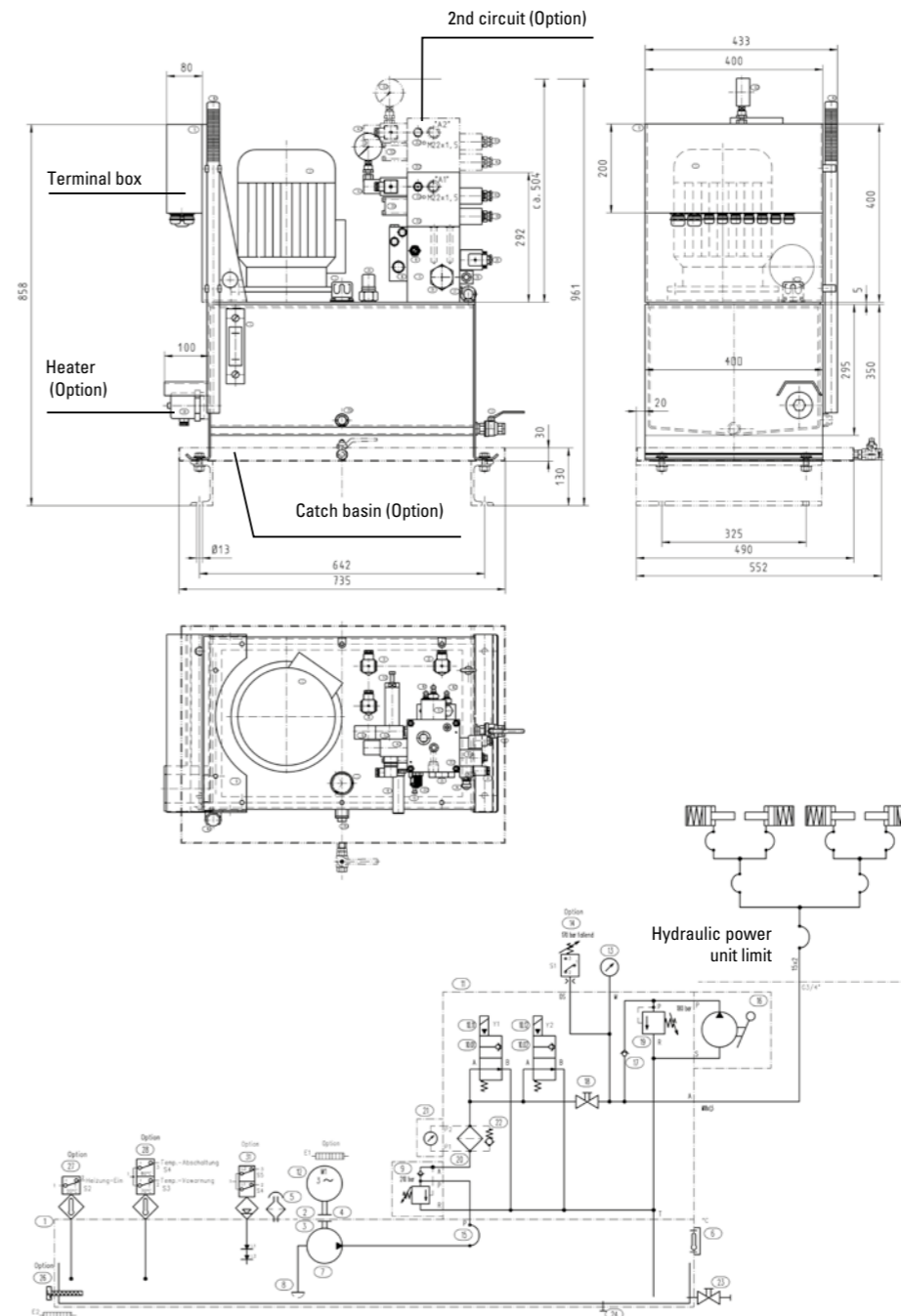

Example:	
Standard configuration	
up to 4	SF10/SF15
up to 2	SF24
Motor:	3 kW
Pump:	7,9 l/min
Pressure:	210 bar
Tank:	40 l
Weight:	85 kg

The flow diagram shows the general arrangement of the hydraulic power unit, including hand pump for emergency manual release of the brakes.

The two solenoid valves are connected in parallel (redundancy). After the nominal pressure is reached, the idler valve switches into idle running. The motor is continuously energized.

Pressure switch, temperature switch, heaters, level switch, stainless steel version and other accessories are available options.

Hydraulic power units are also available as dual-circuit power units, e.g. to operate main hoist and boom hoist brakes with one power unit only.

All dimensions in mm
Alterations reserved without notice

We supply a complete hydraulic and electric diagram according to the order specification with every order.

B

Piping Samples

Disc brakes SF and BSC



Rev. 09-02

Example:
Piping of one brake unit – one hydraulic power unit

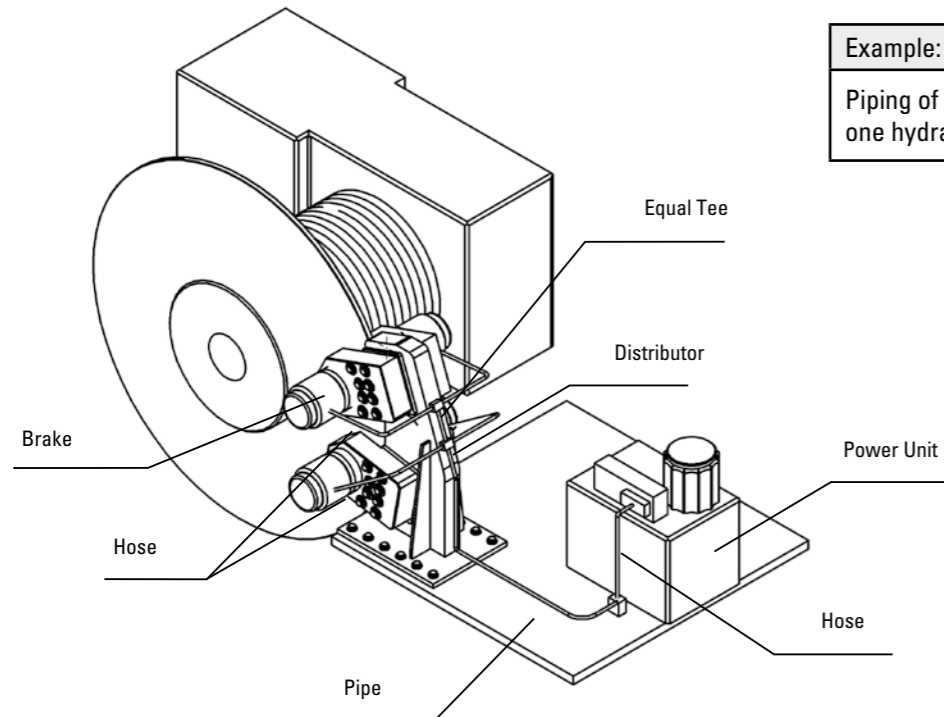

Example:
Piping of two brake units - one hydraulic power unit

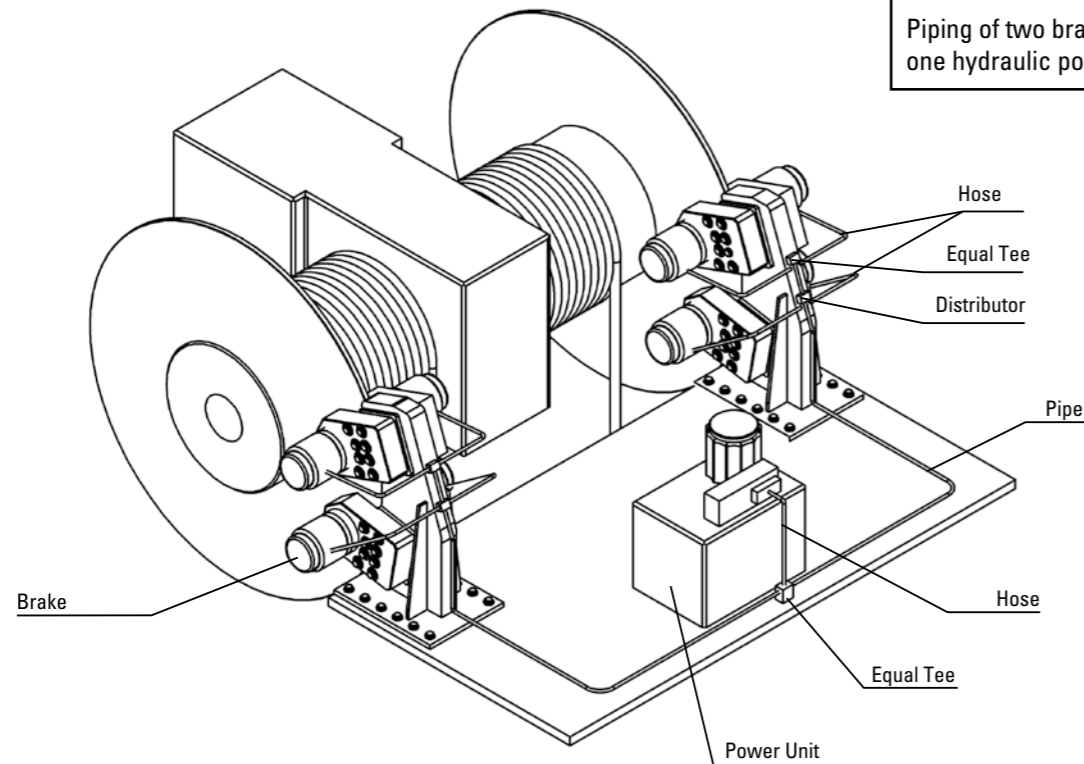

Attention: For operating two brake units with one power unit please note, that the power unit should be installed between the brakes in the centre to achieve almost equal pipe length on both sides (equal apply time of brakes).

Hydraulic Caliper Disc Brakes BSC Series



B

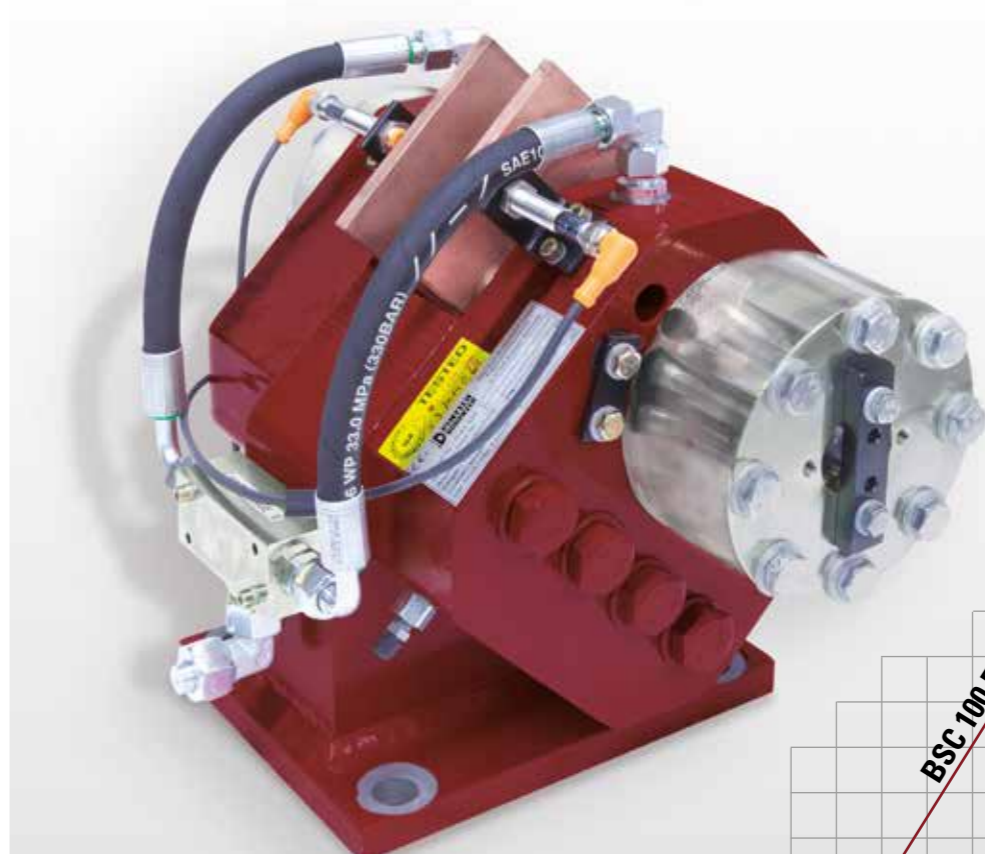

PINTSCH BUBENZER
is certified according to
DIN EN ISO 9001:2015

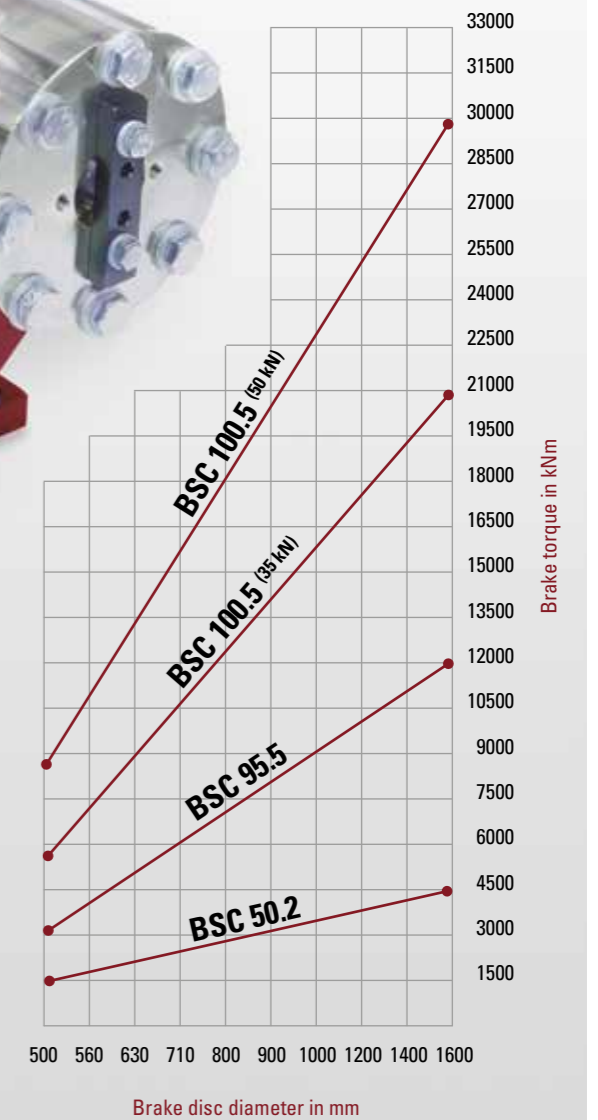

Compact Design



High Performance



Reliable



Robust Design

Description BSC



Main Features

- Two identical caliper halves, ready for operation, with spring packs set to nominal force
- Up to 1 mm air gap between brake pad and disc
- Easy, manual pad wear compensation
- Sintered linings

Applications

- The high capacity of these brakes makes them particularly suitable as service- or secondary emergency brakes e.g. on hoists, slewing drives and belt conveyors
- Other applications are in material handling, mechanical engineering and wind turbine industry, where high holding forces are required independent of the direction of rotation within limited space

Options

- Limit switch release control
- Limit switch wear control
- Complete piped supports for one or more calipers
- Hydraulic power units
- Special seals for flameproof fluids
- Cleaning pads
- Brake discs

Operating Restrictions

- Brakes of this range are mechanically and hydraulically tested and are set to nominal force. This setting can only be changed by the manufacturer. Operating conditions other than described in this brochure require the manufacturer's approval and may influence the function of the caliper and its components

Disc Brake BSC

Dimensions and technical data



Rev. 03-16

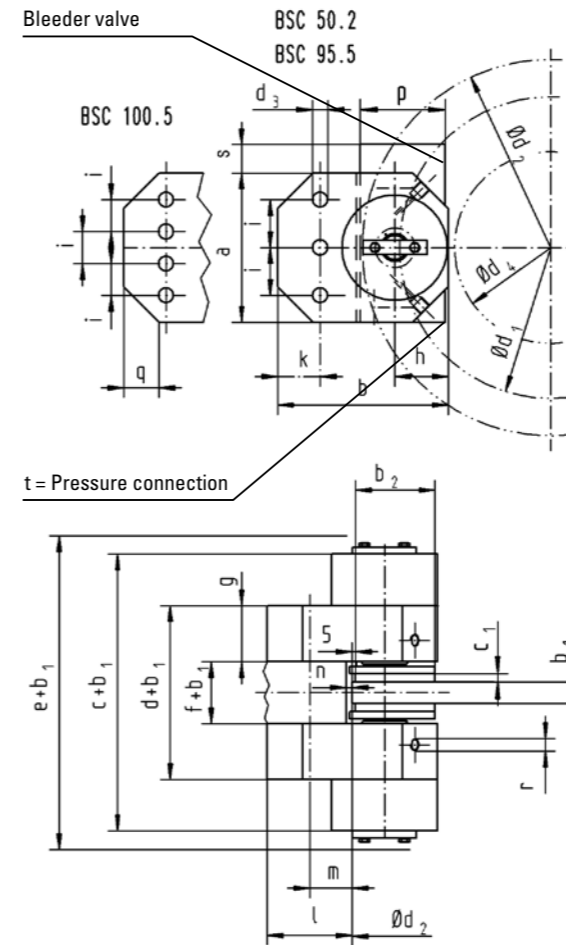

*) Average friction factor of standard material combination

All dimensions in mm
Alterations reserved without notice

$$\text{Brake torque } M_{Br} \text{ in Nm} = F_A \text{ (kN)} \times \mu \times d_1 \text{ (mm)}$$

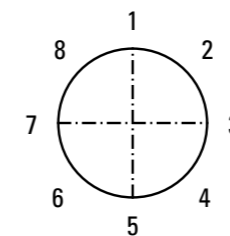

Please indicate required mounting position

Type BSC	50.2	95.5	100.5	
a	130	220	210	
b	128	213	240	
b ₂	63	112	112	
c	224	380	360	
c ₁	6	12	12	
d	108	137	215	
d ₃	14	21	22	
e	302	435	412	
f	38	57	57	
g	35	40	79	
h	42	75	75	
i	35	47,5	45	
k	24	32	60	
l	53	78	119	
m	29	46	59	
n	7	8	8	
p	70	120	120	
q	30x30°	25x45°	50x45°	
r	1/4"	3/8"	3/8"	
s	30	34	40	
t	ø10	ø12	ø12	
Bolt ø	M12	M20	M20	
Bolt material	8.8	8.8	10.9	
Tightening torque Nm	86	410	560	
Contact force F _A kN	7	20	35	50
Op. pressure bar	60	60	100	160
Max. pressure bar	90	100	180	
Release stroke mm	1	1	1	
Oil volume l	0,002	0,004	0,005	
Pad surface cm ²	73	195	195	
Theor. friction μ*	0,40	0,40	0,40	
Weight (kg)	12	30	40	

Data per caliper half

	BSC 50.2	BSC 95.5	BSC 100.5
d ₁	d ₂ -70 mm	d ₂ -105 mm	d ₂ -105 mm
d ₄	d ₂ -170 mm	d ₂ -284 mm	d ₂ -260 mm

d₂ = Brake disc diameter in mm
d₁ = Friction diameter in mm
d₄ = Max. permissible drum or hub diameter in mm
b₁ = Disc thickness in mm (min. 30)



Please Note

We supply a detailed operating manual with every order. Nevertheless, we would point out that brakes are only as safe as the servicing and maintenance performed while they are in operation. The guarantee for the correct functioning of our brakes is only valid if the user adheres to the German DIN standard 15434 part 2 (drum and disc brakes, servicing and maintenance in operation), or to comparable standards in his own country.



PINTSCH BUBENZER Service

This includes the verification of the brake selection, if required. A detailed questionnaire is provided for this purpose. Installation and commissioning on-site by PINTSCH BUBENZER service engineers is possible. Drawings as DWG/DXF files for your engineering department are available upon request.

Disc Brake BSC

Hydraulic power unit for one or more calipers



Rev. 05-17

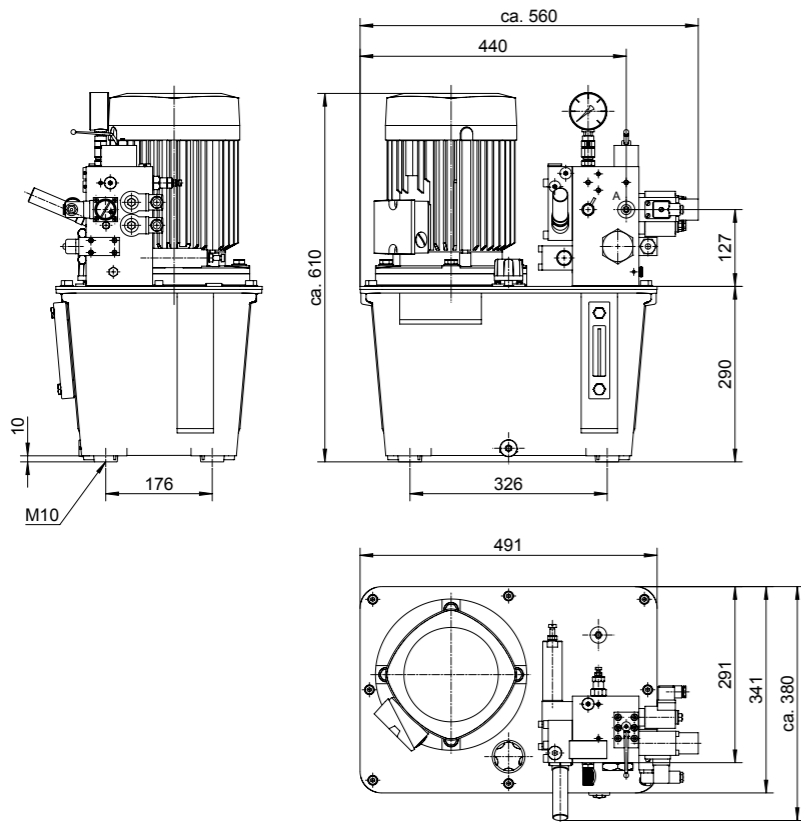

Example:	
Standard configuration	up to 4 BSC 100.5
Motor:	3 kW
Pump:	7,9 l/min at 50 Hz
Pressure:	180 bar
Tank:	30 l

The flow diagram shows the general arrangement of the hydraulic power unit, including hand pump for emergency manual release of the brakes.

The two solenoid valves are connected in parallel (redundancy). After the nominal pressure is reached, the idler valve switches into idle running. The motor is continuously energized. Pressure switch, temperature switch, space heater and other accessories are available as options.

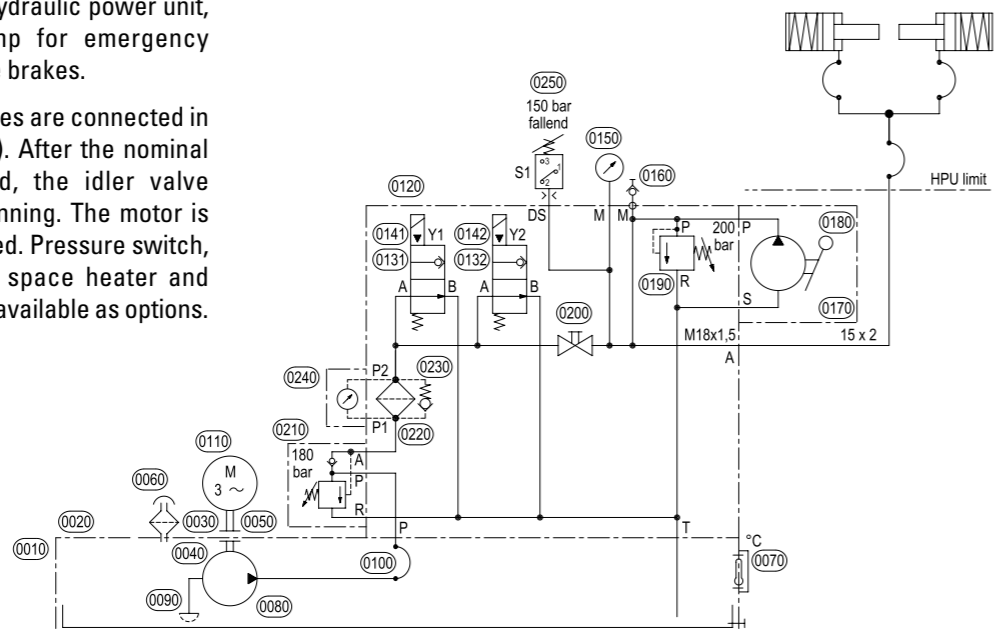

All dimensions in mm
Alterations reserved without notice

We supply a complete hydraulic and electric diagram according to the order specification with every order.

Hydraulic Caliper Disc Brakes BAC Series



B



PINTSCH BUBENZER
is certified according to
DIN EN ISO 9001:2015

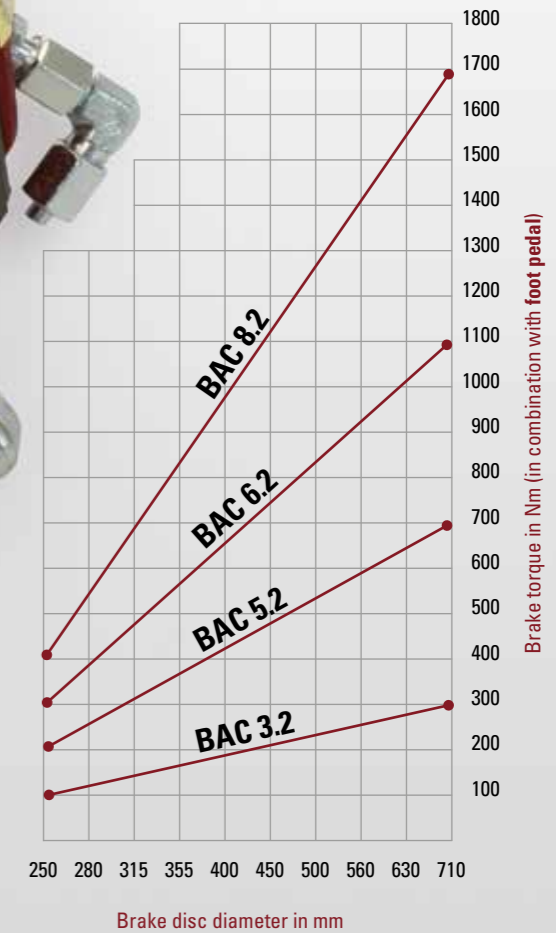

Compact Design



Direct-acting braking

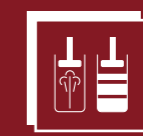

Hydraulic/Pneumatic



Robust Design

Description BAC



Main Features

- Brake hydraulic or pneumatic applied, spring released
- **No failsafe function!**
- Adjustable retraction springs
- Automatic wear adjusting brake linings
- Organic, non-asbestos linings
- Operation by foot pedal or separate hydraulic power unit
- Air gap between brake pad and disc up to 2 mm per side

Options

- Limit switch release control
- Sintered linings
- Complete piped supports for one or more calipers
- Hydraulic power units
- Pneumatic power units
- Hydraulic foot pedals (see page 75)
- Brake discs
- Extended air gap more than 2 mm on request

Applications

- Stopping and/or holding of fans, blowers, wind turbines, coilers, crane slewing and travel gears etc..

Disc Brake BAC

Dimensions and technical data



Rev. 03-16

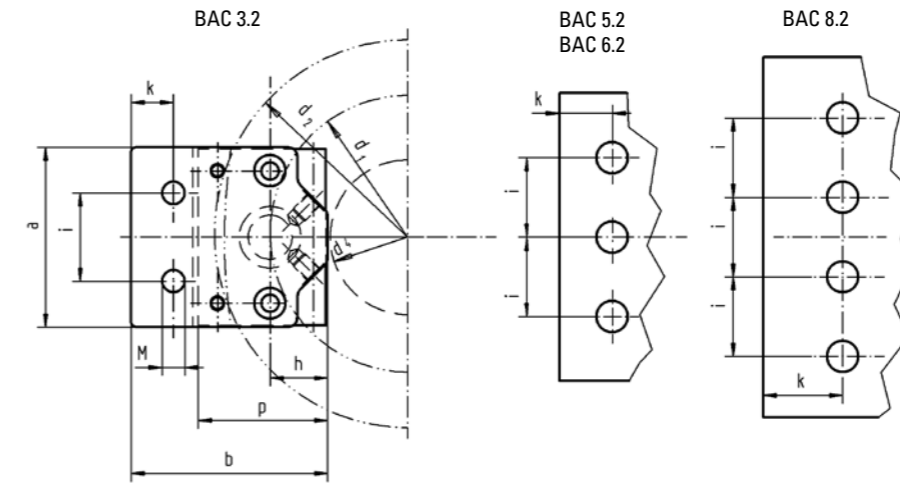

f₁ = Factor, see table
 f₂ = Factor, see table
 d₂ = Disc diameter in mm
 p_{vorh} = Existing operating pressure in bar

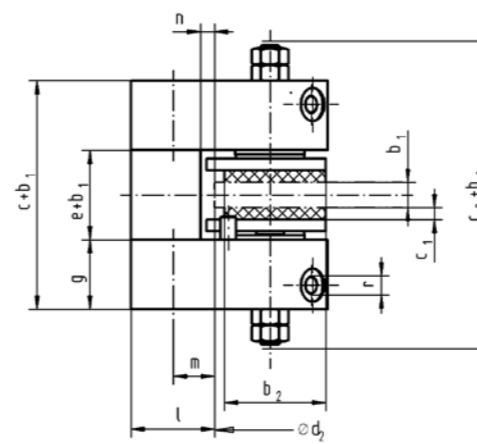

All dimensions in mm
 Alterations reserved without notice

$$\text{Brake torque } M_{Br} \text{ in Nm} = f_1 \times (d_2 - f_2) \times p_{vorh}$$

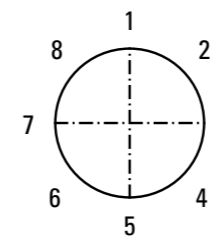

Please indicate required mounting position

Type BAC	3.2	5.2	6.2	8.2
a	102	130	163	204
b	100	120	141	182
b ₂	51	63	82	95
c	103	137	156	178
c ₁	6	6	8	8
c ₂	143	164	188	244
g	35	50	54	65
h	30	40	46	60
i	50	35	45	45
k	24	26	30	45
l	42	47	50	72
m	16	19	20	27
n	7	7	6	10
p	62	79	97	120
r	1/8"	1/8"	1/4"	3/8"
e	33	37	48	48
Bolt \varnothing	M10	M12	M16	M16
Bolt material	10.9	10.9	10.9	10.9
Tighten. torque, Nm	69	120	295	295
Pad surface cm ²	46,5	74	118	168
Piston surface cm ²	9,5	19	33	50
Max. pressure bar	90	120	120	120
Max. stroke mm	1,6	2	2	2
Weight (kg)	8	10	20	35
Factor f ₁	0,033	0,067	0,115	0,175
Factor f ₂	60	70	90	100

Data per caliper half



Please Note

We supply a detailed operating manual with every order. Nevertheless, we would point out that brakes are only as safe as the servicing and maintenance performed while they are in operation. The guarantee for the correct functioning of our brakes is only valid if the user adheres to the German DIN standard 15434 part 2 (drum and disc brakes, servicing and maintenance in operation), or to comparable standards in his own country.



PINTSCH BUBENZER Service







This includes the verification of the brake selection, if required. A detailed questionnaire is provided for this purpose. Installation and commissioning on-site by PINTSCH BUBENZER service engineers is possible. Drawings as DWG/DXF files for your engineering department are available upon request.

B

G



PINTSCH BUBENZER
is certified according to
DIN EN ISO 9001:2015

					
Compact Design	Easy Maintenance	High Performance	Reliable	Robust Design	Tried and Trusted

Description SFB Series



Main Features

Spring applied safety brake
Electromechanically released
Protection-class IP67
Double wear reserve by single air gap adjustment
High work capacity
High wear resistance because of high abrasion resistance
Functional without cover
Emergency release screws

Applications

Gantry, trolley and hoisting applications
Electrical drives for ship winches and deck machinery
Jack up systems at offshore systems
Dynamic and static use at general industrial applications
Steel mills

Certificates

ABS, DNV, LR, GL, RMROS, BV

Options

Special brake torque: Lower brake torque = type SFB Higher brake torque = type SFB-SH
Holding brake torques available on request
Micro- or proximity switches: • Monitoring the function on/off • Maximum air gap (wear-monitoring)
Lateral junction box
Tacho preparation with all mounting parts
Cover bore
Shaft sealing
Special voltage
Anti condensation heater
Radial cable outlet
Special flange

Electrical equipment

One-way, bridge and switching rectifier
Protective element
Brake control unit = BCU 2001
Brake control and monitoring system = BCMS-4

Spring Set Brake SFB

Electromagnetic Two Disc, Spring Set Brake



Rev. 05-08

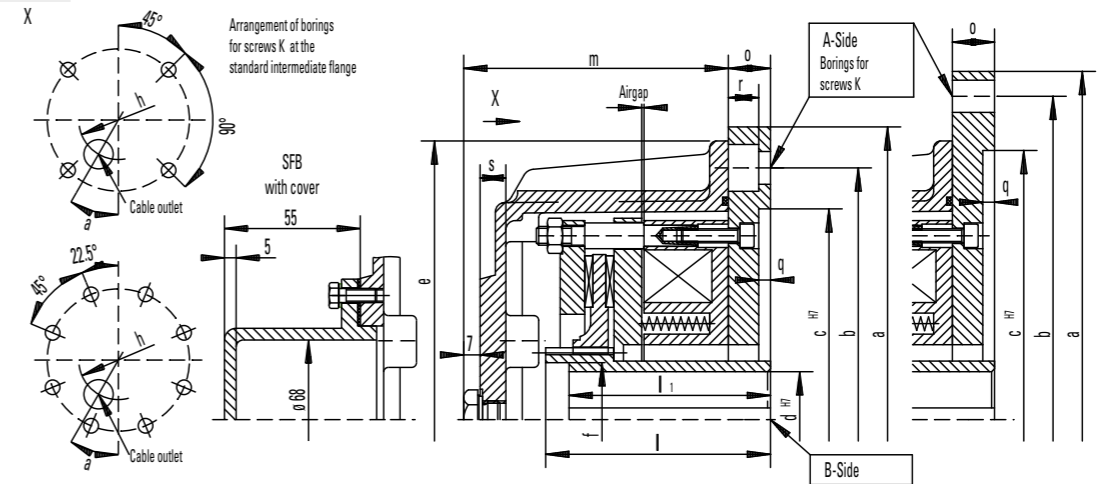

Keyways for keys acc. to DIN6885 Bl.1, width accuracy P9. Protection IP67

Alterations reserved without notice

Brake size		SFB 6.3	SFB 10	SFB 16	SFB 25	SFB 40	SFB 63	SFB 100	SFB 160	SFB 250				
Brake torque M2 dynamic acc. to DIN VDE 0580	Nm	63	100	160	250	400	630	1000	1600	2500				
		54	80	130	210	330	520	830	1300	2100				
		45	63	100	180	260	400	660	1050	1650				
Mass moment of inertia	kgm ²	0.0017	0.0037	0.0048	0.0068	0.0175	0.036	0.050	0.128	0.140				
Mass (weight)	kg	19	28	42	55	74	106	168	242	306				
max. speed	min ⁻¹	6000	6000	6000	5500	4700	4000	3600	3200	2800				
Coil b. 20° C	Nominal voltage	V DC	110	110	110	110	110	110	110	110				
	Nominal power	W	99	128	158	196	220	307	344	435				
	Nominal current	A	0.90	1.16	1.44	1.78	2.0	2.79	3.13	3.95				
Air gap, brake OFF	min. mm	0.3	0.3	0.3	0.4	0.4	0.4	0.6	0.4	0.4				
	max. mm	0.9	1.2	1.2	1.3	1.4	1.8	1.8	2.3	2.5				
Diameter mm	B-Side	d Rough boring	26	26	36	36	36	36	36	46	46			
		d ^{H7} Preferential boring	28	28	38	38	48	60	60	65	65			
			32	32	42	42	55	65	65	70	70			
			38	38	48	48	60	75	75	75	75			
										80	80			
								90	90					
		d ^{H7} maximal	40	40	55	55	60	75	75	110	110			
Length mm	e	238	260	280	318	400	440	446	540	556				
	f						95	95	128	128				
	h	150	180	202	214	244	292	330	394	440				
	l	96	96	117	117	142	148	148	191	191				
	l'	96	96	117	117	142	142	142	171	171				
	m	115	118	137	143	169	171	183	211	232				
s	11	11	11	12	14	15	15	15	15					
A	α°	15	15	30	22.5	30	30	30	30	45				
Suitable standard intermediate flange		A250	A300	A300-1	A350	A400-1	A450-1	A450-1	A550-1	A660	A800			
		A300	A350	A350	A400	A450	A550	A660	A660	A800				
				A400	A450	A550	A660	A660	A800					
				A450										
Dimensions of standard intermediate flange		Standard intermediate flange												
		a	250	300	300	350	400	400	450	450	550	550	660	800
		b	215	265	265	300	350	350	400	400	500	500	600	740
		c ^{H7}	180	230	230	250	300	300	350	350	450	450	550	680
		o	18	18	18	20	22	22	24	24	24	24	30	30
Length mm	q	5	5	5	6	6	6	6	6	6	7	7		
	r	13		13			17.5		17.5		17.5			
	Screws k	4xM12	4xM12	4xM12	4xM16	4xM16	4xM16	4xM12	8xM16	8xM16	8xM16	8xM20		



Please Note

We supply a detailed operating manual with every order. Nevertheless, we would point out that brakes are only as safe as the servicing and maintenance performed while they are in operation. The guarantee for the correct functioning of our brakes is only valid if the user adheres to the German DIN standard 15434 part 2 (drum and disc brakes, servicing and maintenance in operation), or to comparable standards in his own country.



PINTSCH BUBENZER Service

This includes the verification of the brake selection, if required. A detailed questionnaire is provided for this purpose. Installation and commissioning on-site by PINTSCH BUBENZER service engineers is possible. Drawings as DWG/DXF files for your engineering department are available upon request.

Spring Set Brake SFB

Electromagnetic Two Disc, Spring Set Brake



Rev. 05-08

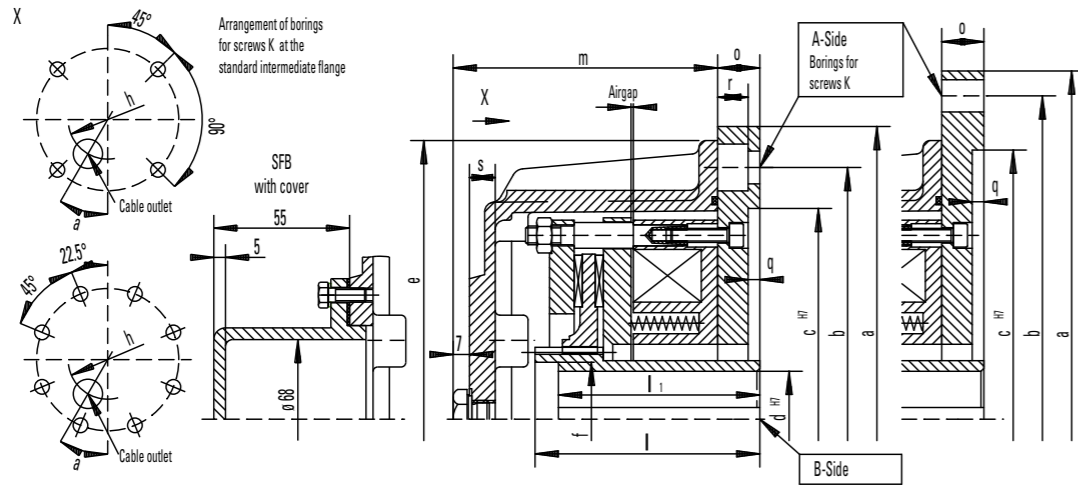

Brake size		SFB 400	SFB 630	SFB 1000	
Brake torque M2 dynamic acc. to DIN VDE 0580	Nm	4000	6300	10000	
		3350	5250	8500	
		2650	4200	7000	
Mass moment of inertia	kgm ²	0.325	0.375	1.007	
Mass (weight)	kg	357	500	750	
max. speed	min ⁻¹	2500	2200	2000	
Coil b. 20° C	Nominal voltage	V DC	110	110	110
	Nominal power	W	553	671	980
	Nominal current	A	5.03	6.10	8.91
Air gap, brake OFF		min. mm	0.4	0.7	0.7
		max. mm	2.5	2.8	3.1
Diameter mm	B-Side	d Rough boring	46	58	68
		d ^{H7} Preferential boring	65	100	125
			70		
			75		
			80		
		90			
		d ^{H7} maximal	110	125	140
Length mm	e	660	700	795	
	f	128	140	155	
	h	520	570	620	
	l	191	237	282	
	l'	171	210	255	
	m	272	310	360	
	s	15	15	15	
A	α°	30	30	30	
Suitable standard intermediate flange		A660-1	A800	A800-1	
		A800			
		Dimensions of standard intermediate flange			
Diameter mm	Standard intermediate flange		A660-1	A800	A800-1
	a		660	800	800
	b		600	740	740
	c ^{H7}		550	680	680
Length mm	o		30	30	30
	q		7	7	7
	r		21.5		21.5
Screws k			8xM20	8xM20	8xM20

Keyways for keys acc. to DIN6885 BI.1, width accuracy P9. Protection IP67

Alterations reserved without notice

Spring Set Brake SFB-SH

Electromagnetic Two Disc, Spring Set Brake
Increased brake torque



Rev. 05-08

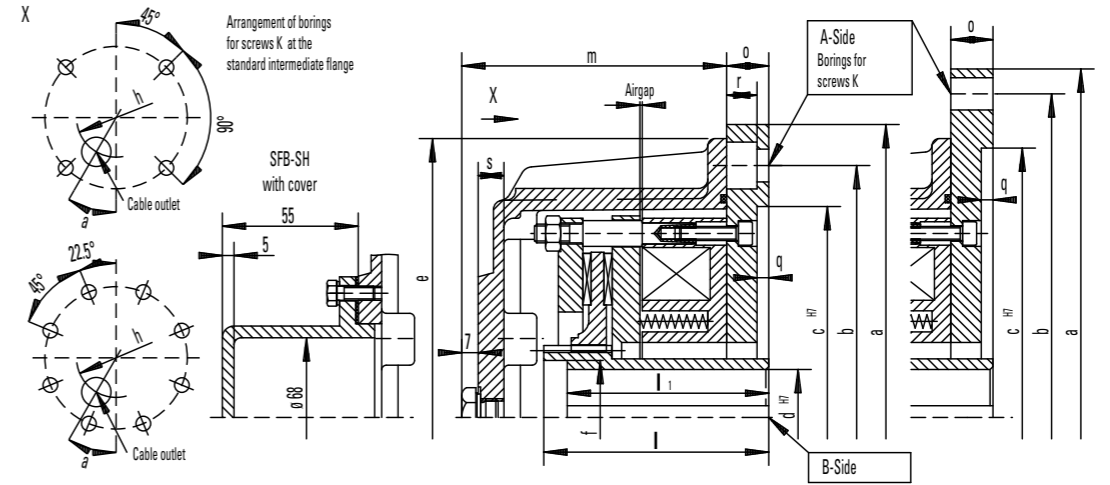

Keyways for keys acc. to DIN6885 BI.1, width accuracy P9. Protection IP67

Alterations reserved without notice

Brake size		SFB 6.3-SH	SFB 10-SH	SFB 16-SH	SFB 25-SH	SFB 40-SH	SFB 63-SH	SFB 100-SH	SFB 160-SH	SFB 250-SH				
Brake torque M2 dynamic acc. to DIN VDE 0580	Nm	80	130	210	350	550	800	1300	2100	3300				
		75	120	190	310	490	750	1200	1900	3000				
		69	110	180	275	440	690	1100	1750	2750				
Mass moment of inertia	kgm ²	0.0017	0.0037	0.0048	0.0068	0.0175	0.036	0.050	0.128	0.140				
Mass (weight)	kg	19	28	42	55	74	106	168	242	306				
max. speed	min ⁻¹	6000	6000	6000	5500	4700	4000	3600	3200	2800				
Coil b. 20° C	Nominal voltage	V DC	110	110	110	110	110	110	110	110				
	Nominal power	W	99	128	158	196	220	307	344	435	495			
	Nominal current	A	0.90	1.16	1.44	1.78	2.0	2.79	3.13	3.95	4.50			
Air gap, OFF		min. mm	0.3	0.3	0.3	0.4	0.4	0.4	0.6	0.4				
		max. mm	0.9	1.2	1.2	1.3	1.4	1.8	1.8	2.3				
Diameter mm	B-Side	d Rough boring	26	26	36	36	36	36	36	46	46			
		d ^{H7} Preferential bore	28	28	38	38	48	60	60	65	65			
			32	32	42	42	55	65	65	70	70			
			38	38	48	48	60	75	75	75	75			
					55	55				80	80			
		d ^{H7} maximal	40	40	55	55	60	75	110	110				
Length mm	e	238	260	280	318	400	440	446	540	556				
	f						95	95	128	128				
	h	150	180	202	214	244	292	330	394	440				
	l	96	96	117	117	142	148	148	191	191				
	l'	96	96	117	117	142	142	142	171	171				
	m	115	118	137	143	169	171	183	211	232				
	s	11	11	11	12	14	15	15	15	15				
A	α°	15	15	30	22.5	30	30	30	30	45				
Suitable standard intermediate flange		A250	A300	A300-1	A350	A400-1	A450-1	A450-1	A550-1	A660	A800			
		A300	A350	A350	A400	A450	A550	A660	A660	A800				
		Dimensions of standard intermediate flange												
Diameter mm	Standard intermediate flange		A250	A300	A300-1	A350	A400	A400-1	A450	A450-1	A550	A550-1	A660	A800
	a		250	300	300	350	400	400	450	450	550	550	660	800
	b		215	265	265	300	350	350	400	400	500	500	600	740
	c ^{H7}		180	230	230	250	300	300	350	350	450	450	550	680
Length mm	o		18	18	18	20	22	22	24	24	24	24	30	30
	q		5	5	5	6	6	6	6	6	6	6	7	7
	r		13		13				17.5		17.5			
Screws k			4xM12	4xM12	4xM12	4xM16	4xM16	4xM16	8xM16	8xM16	8xM16	8xM16	8xM20	8xM20



Spring Set Brake SFB-SH

Electromagnetic Two Disc, Spring Set Brake
Increased brake torque



Rev. 05-08

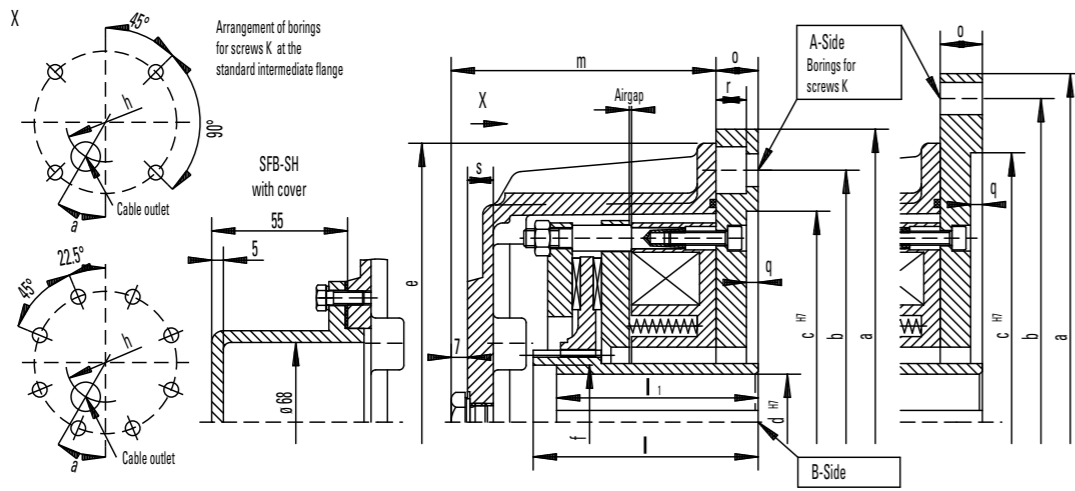

Brake size		SFB 400-SH	SFB 630-SH	SFB 1000-SH	
Brake torque M2 dynamic acc. to DIN VDE 0580	Nm	5200	8000	13000	
		4800	7500		
		4400	6900		
Mass moment of inertia	kgm ²	0.325	0.375	1.007	
Mass (weight)	kg	357	500	750	
max. speed	min ⁻¹	2500	2200	2000	
Coil h. 20° C	Nominal voltage	V DC	110	110	110
	Nominal power	W	553	671	980
	Nominal current	A	5.03	6.10	8.91
Air gap, brake OFF	min. mm	0.4	0.7	0.7	
	max. mm	2.5	2.8	3.1	
Diameter mm	B-Side	d Rough boring	46	58	68
		d ^{H7} Preferential boring	65	100	125
			70		
			75		
			80		
d ^{H7} maximal	110	125	140		
Length mm	e	660	700	795	
	f	128	140	155	
	h	520	570	620	
	l	191	237	282	
	l ¹	171	210	255	
	m	272	310	360	
A	s	15	15	15	
Suitable standard intermediate flange	α°	30	30	30	
		A660-1	A800	A800-1	
		A800			
Dimensions of standard intermediate flange					
Diameter mm	Standard intermediate flange		A660-1	A800	A800-1
	a		660	800	800
	b		600	740	740
Length mm	c ^{H7}		550	680	680
	o		30	30	30
	q		7	7	7
	r		21.5		21.5
Screws k			8xM20	8xM20	8xM20

Keyways for keys acc. to DIN6885 B1.1,
width accuracy P9. Protection IP67

Alterations reserved without notice

Spring Set Brake KFB



PINTSCH BUBENZER
is certified according to
DIN EN ISO 9001:2015



Compact Design



Easy Maintenance



High Performance



Reliable



Robust Design



Tried and Trusted

Description KFB



Main Features

- Spring applied safety brake
- Electromechanically released
- Protection-class IP67 – seawater protected
- High wear reserve by multiple air gap adjustment
- Small construction at high work capacity
- High availability caused by high durability
- Functional without cover
- Emergency release screws

Applications

- Gantry, trolley and hoisting application
- Dynamic and static use at general industrial applications
- General engineering
- Steel mills
- Wind energy systems
- Coal mining

Certificates

- ABS, Atex, UL / CSA

Options

- Special brake torque
- Handlever
- Micro or proximity switch:
 - Monitoring the function on/off
 - Maximum air gap (wear-monitoring)
- Lateral junction box
- Tacho preparation with all mounting parts
- Cover bore
- Shaft sealing
- Special voltage
- Anti condensation heater
- Radial cable outlet
- Special flange

Electrical equipment

- One-way, bridge and switching rectifier
- Protective element
- Brake control unit = BCU 2001
- Brake control and monitoring system = BCMS-4

Spring Set Brake KFB

Electromagnetic Two Disc, Spring Set Brake



Rev. 10-09

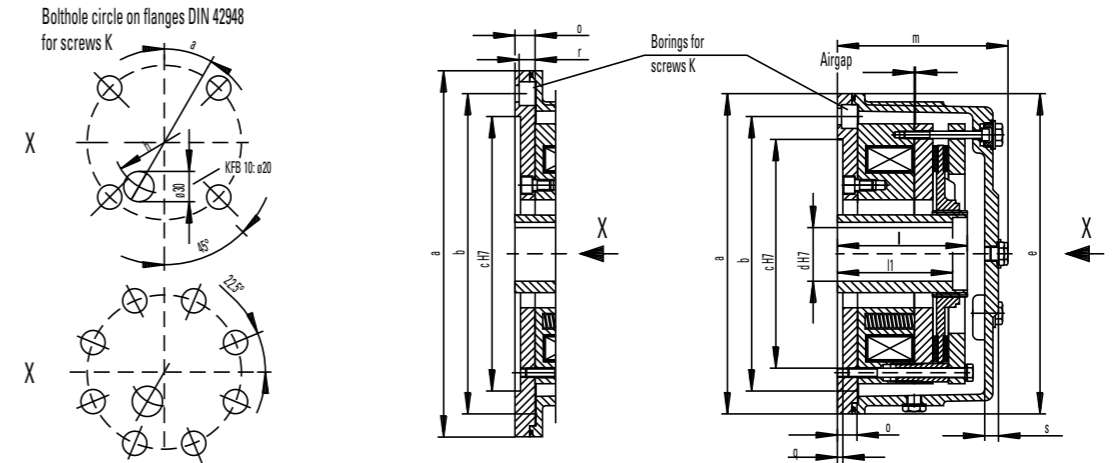

* The larger dimension belongs to the larger assigned brake

Alterations reserved without notice

Brake size		KFB 5	KFB 10	KFB 16	KFB 25	KFB 30	KFB 40	KFB 63	KFB 100	KFB 160	
Brake torque M2 dynamic acc. to DIN VDE 0580	Nm	50	100	160	250	300	400	630	1000	1600	
Mass moment of inertia	kgm ²	0.0010	0.0017	0.0037	0.0048	0.0055	0.0068	0.0175	0.036	0.050	
Mass (weight)	kg	13	19	28	42	50	55	74	106	168	
max. speed	min ⁻¹	6000	6000	6000	6000	6000	5500	4700	4000	3600	
Coil b. 20° C	Nominal voltage	V DC	110	110	110	110	110	110	110	110	
	Nominal power	W	79	93	128	158	133	196	220	307	
	Nominal current	A	0.72	0.84	1.16	1.44	1.2	1.78	2.0	2.79	
Air gap, OFF	norm. mm	0.3	0.3	0.3	0.3	0.3	0.3	0.4	0.4	0.4	
	max. mm	0.8	1.0	1.0	1.2	0.8	1.2	1.3	1.6	1.8	
Diameter mm	B-Side	d pilot bore	8	26	26	36	26	36	36	36	36
		d ^{H7} preferential bore	15	28	28	38	32	38	48	60	60
			20	32	32	42	38	42	55	65	65
			25	38	38	48	42	48	60	75	75
Length mm	e	160/200	200/250	253/303	300/350	250/300	303/350	350/400	400/450	450/550	
	f										
	h	93	106	144	194	144	194	214	264	314	
	l	110	110	96	117	137	117	142	148	155	
	l'	110	110	96	117	137	117	142	142	142	
	m	145	154	141	165	175	175	187	196	218	
s	13	15	15	15	15	15	15	15	15	17	
A	α°	22.5	30	30	30	67.5	30	30	30	30	
Suitable standards flanges		A160	A200	A250	A300	A250	A300	A350	A400	A450	
		A200	A250	A300	A350	A300	A350	A400	A450	A550	
Dimensions of standards flanges											
		Size of standards flanges	A160	A200	A250	A300	A350	A400	A450	A550	
Diameter mm	a	160	200	250	300	350	400	450	550		
	b	130	165	215	265	300	350	400	500		
	c ^{H7}	110	130	180	230	250	300	350	450		
Length mm	o	18	18	18/20*	20/22*	22	22/24*	24/29*	24/29*		
	q	5	5	5	5	6	6	6	6		
	r	11	11	13	13	17.5	17.5	17.5	17.5		
Screws	k	4xM8	4xM10	4xM12	4xM12	4xM16	4xM16	8xM16	8xM16		



Please Note

We supply a detailed operating manual with every order. Nevertheless, we would point out that brakes are only as safe as the servicing and maintenance performed while they are in operation. The guarantee for the correct functioning of our brakes is only valid if the user adheres to the German DIN standard 15434 part 2 (drum and disc brakes, servicing and maintenance in operation), or to comparable standards in his own country.



PINTSCH BUBENZER Service

This includes the verification of the brake selection, if required. A detailed questionnaire is provided for this purpose. Installation and commissioning on-site by PINTSCH BUBENZER service engineers is possible. Drawings as DWG/DXF files for your engineering department are available upon request.

Notes



Accessories



PINTSCH BUBENZER
is certified according to
DIN EN ISO 9001:2015

- Compact Design
- Easy Maintenance
- High Performance
- Reliable
- Robust Design
- Tried and Trusted

Description Accessories



Specific Features for the rectifiers BGL and EGL

- Prepared for switching AC and DC circuits simultaneously
- Installation in cabinet

Specific Features for the protective element PE 400/150/5

- To be connected parallel to the output of the rectifiers BGL, EGL and SGL to increase the interruption capacity

Specific Features for the rectifiers FWR and HWR

- Prepared for switching AC and DC circuits simultaneously
- Installation in junction box

Specific Features of the switching rectifier SGL

- Prepared for switching AC and DC circuits simultaneously
- Switches from bridge rectification to half-wave rectification
- Four time settings 0,5 s, 1 s, 1,5 s, 2 s adjustable
- Applying brakes at elevated temperatures
- Accelerated brake release (Overexcitation with AC power supply voltage = 2 x DC coil voltage)
- Accelerated brake effect (Standard excitation with AC power supply voltage = DC coil voltage)

Main Features

- EMC compatibility
- Top-hat rail mounted
- Combinable with Brake Control Unit BCU2001
- Integrated protective element
- Integrated spark quench element

BGL-PE400/150/3 - EGL-PE400/150/5

Principal circuit diagram



Rev. 03-09

Bridge rectification with module BGL

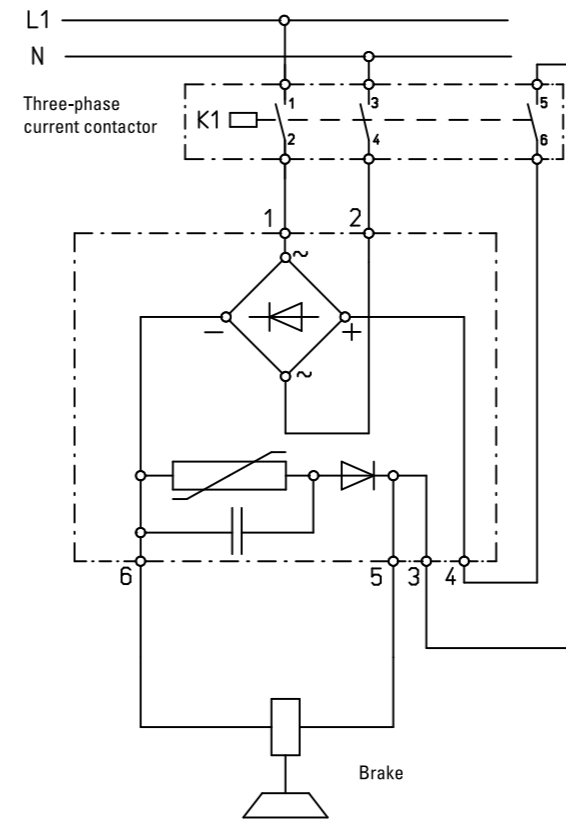

Half-wave rectification with module EGL

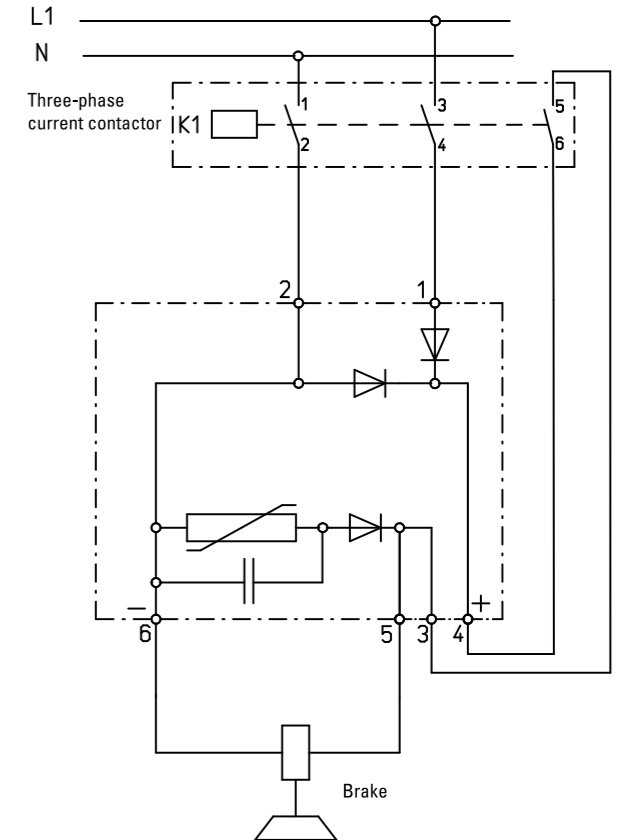

Technical data

Brake rectifier BGL-PE400/150/3

AC line voltage:	AC 460V; 50/60 Hz
Permissible rated coil voltages:	DC 24V... 390V
Maximum brake current:	2,5A
Maximum continuous output of the internal protective circuit:	3W
Disconnection peak at maximum coil current:	≤450V
Ambient temperature:	-40° C ... +50° C
Protection class:	IP 20

Brake rectifier EGL-PE400/150/5

AC line voltage:	AC 460V; 50/60 Hz
Permissible rated coil voltages:	DC 24V ... 220V
Maximum brake current:	5A
Maximum continuous output of the internal protective circuit:	5W
Disconnection peak at maximum coil current:	≤450V
Ambient temperature:	-40° C ... +50° C
Protection class:	IP 20



Please Note

We supply a detailed operating manual with every order. Nevertheless, we would point out that brakes are only as safe as the servicing and maintenance performed while they are in operation. The guarantee for the correct functioning of our brakes is only valid if the user adheres to the German DIN standard 15434 part 2 (drum and disc brakes, servicing and maintenance in operation), or to comparable standards in his own country.



PINTSCH BUBENZER Service

This includes the verification of the brake selection, if required. A detailed questionnaire is provided for this purpose. Installation and commissioning on-site by PINTSCH BUBENZER service engineers is possible. Drawings as DWG/DXF files for your engineering department are available upon request.

Full wave rectifier FWR-PE400/150/3

Principal circuit diagram



Rev. 10-10

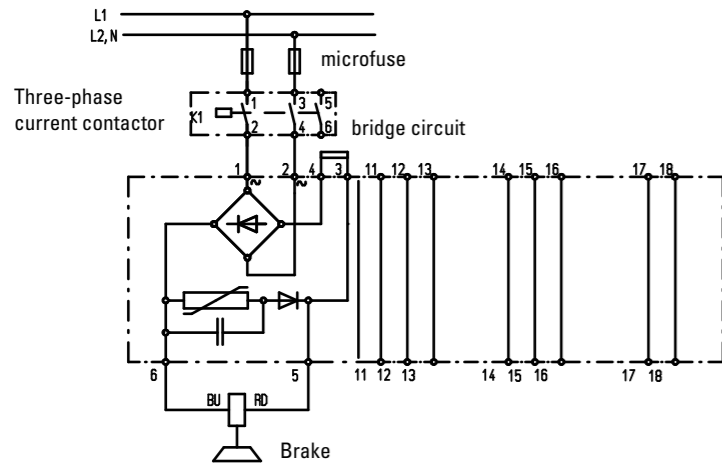

load diagram

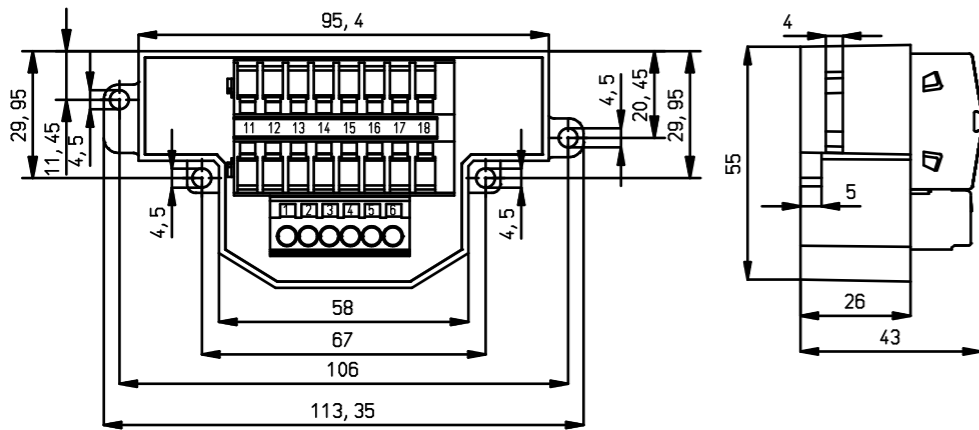
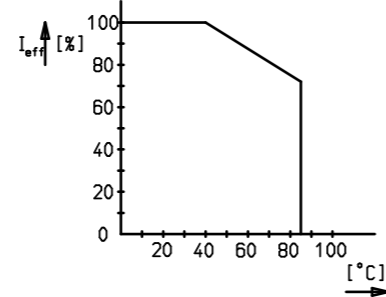

Technical data

Coil voltage of the connected brake	DC 24V ... 390V
Max. voltage of supplying alternating current network	AC 460V - 50/60 Hz
Max. Output current I_{eff} at $T_A = < 50^\circ\text{C}$	2,5 A
Max. Output current I_{eff} at max. T_A 85°C	1,8 A
Protection fuse in the AC input voltage line to the rectifier (In the selection of fuse is permissible on the $I^2 t$ limit load integral to eight)	FF 4A microfuse switching capacity H
Permitted limit integral $I^2 t$	700A ² s (t < 10ms)
Max. energy absorption of a shut-off	150 J
Max. continuous power of the internal protective circuit (average value)	3W
Shut-off peak at max. coil current	< 450V
Ambiente temperature T_A	-40° C ... +85° C
Permissible cross section of connection wire	0,2 ... 2,5 mm AWG 24 ... 14
Weight	0,3 kg
Protection class	IP 65 components seal / IP20 terminals
Mark of conformity	CE / RoHS conform

Half wave rectifier HWR-PE400/150/5

Principal circuit diagram



Rev. 10-10

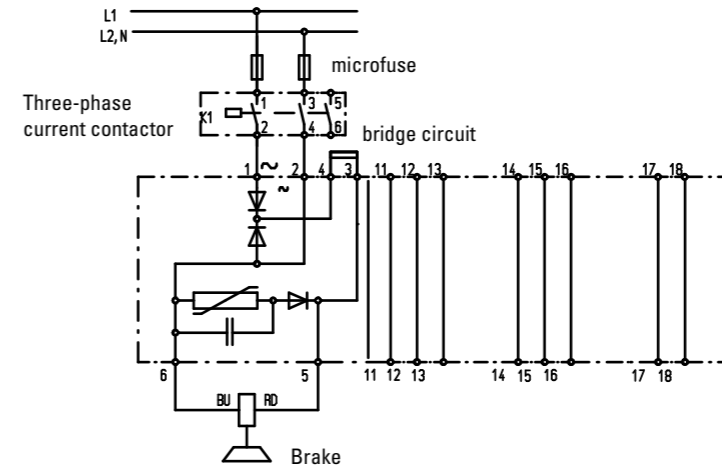

load diagram

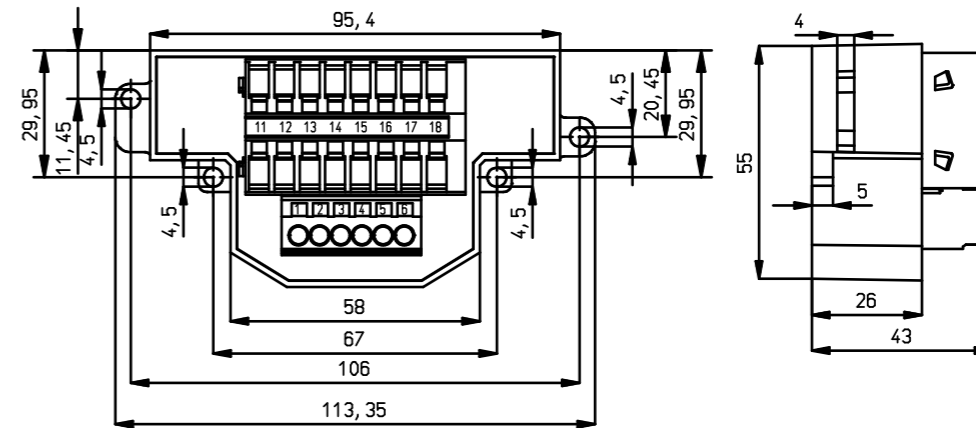
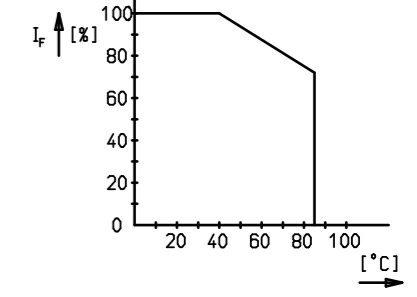

Technical data

Coil voltage of the connected brake	DC 24V ... 240V
Max. voltage of supplying alternating current network	AC 550V - 50/60 Hz
Max. Output current I_{eff} at $T_A = < 50^\circ\text{C}$	5 A
Max. Output current I_{eff} at max. T_A 85°C	3,6 A
Protection fuse in the AC input voltage line to the rectifier (In the selection of fuse is permissible on the $I^2 t$ limit load integral to eight)	FF 4A microfuse switching capacity H
Permitted limit integral $I^2 t$	700A ² s (t < 10ms)
Max. energy absorption of a shut-off	150 J
Max. continuous power of the internal protective circuit (average value)	5W
Shut-off peak at max. coil current	< 450V
Ambiente temperature T_A	-40° C ... +85° C
Permissible cross section of connection wire	0,2 ... 2,5 mm AWG 24 ... 14
Weight	0,3 kg
Protection class	IP 65 components seal / IP20 terminals
Mark of conformity	CE / RoHS conform

Switching rectifier SGL

Principal circuit diagram



Rev. 03-09

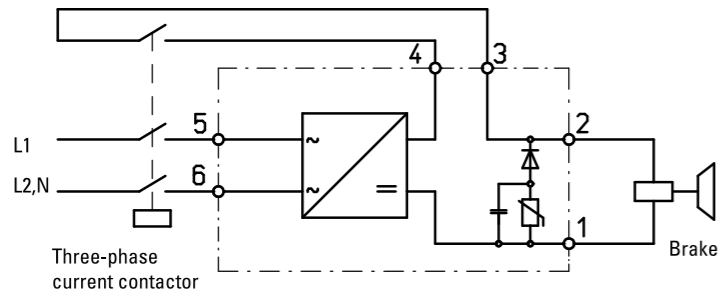

Switching rectification with module SGL

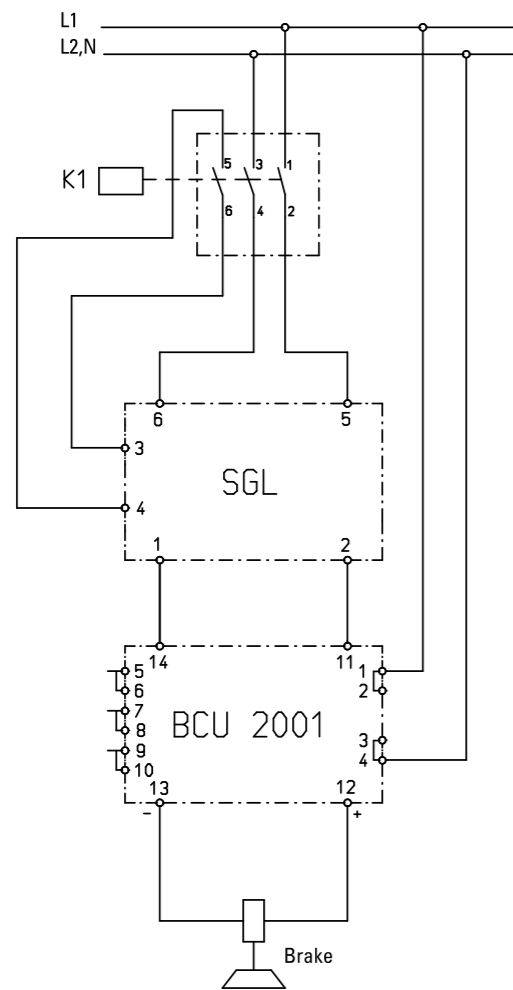

Switching rectification with module SGL combined with the Brake Control Unit BCU2001

Technical data

AC line voltage:	AC 220V ... 484V; 50/60 Hz
Maximum brake current for 2 s:	8A
Maximum continuous output of the internal protective circuit:	5 W
Permanent brake current:	4A
Time settings by DIP switch:	0,5 s, 1 s, 1,5 s, 2,0 s
Ambient temperature:	-40° C ... +50° C
Protection class:	IP 20

Protective element PE-400/150/5

Principal circuit diagram



Rev. 03-09

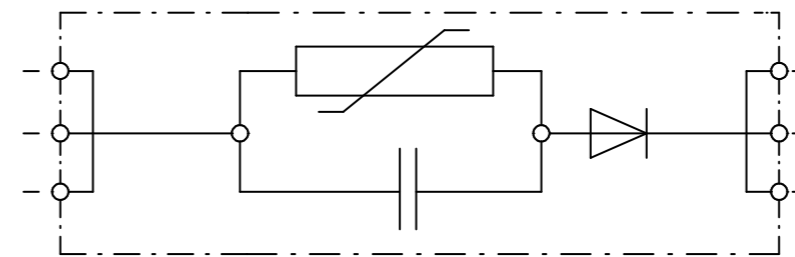

Protective element PE-400/150/5

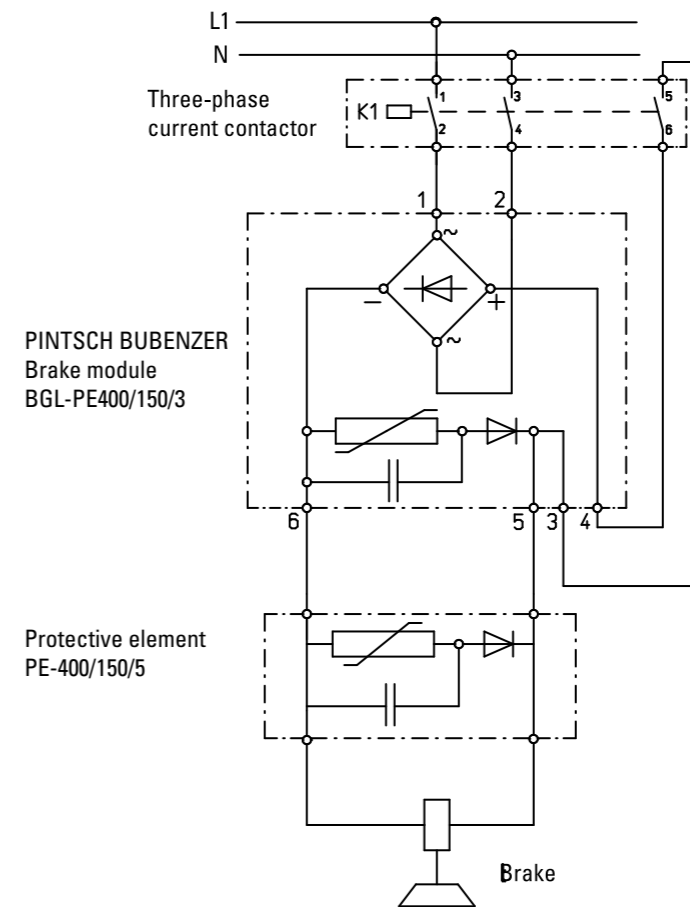

Bridge rectification with module BGL combined with the protective element PE-400/150/5

Technical data

Maximum brake voltage:	DC 400V
Maximum brake current:	5A
Maximum continuous output of the internal protective circuit:	5W
Disconnection peak at maximum coil current:	≤ 450V
Ambient temperature:	-40° C ... +50° C
Protection class:	IP 20





PINTSCH BUBENZER
is certified according to
DIN EN ISO 9001:2015

- Compact Design**
- Easy Maintenance**
- High Performance**
- Reliable**
- Robust Design**
- Tried and Trusted**

Description Brake Control Unit BCU2001



Main Features

- EMC compatibility
- Maximum air gap (wear) indication by LED
- Maximum air gap indication by relay contact
- Function on/off indication by LED
- Function on/off indication by relay contact
- No sensors on the brake
- No sensor wiring to the brake
- Perfect retrofit equipment
- Directly connectable with PLC systems
- AC and DC auxiliary power supplies applicable
- Top-hat rail mounted

Applications

- Container cranes
- Ship winches
- Automatic racking systems
- Conveyor belts
- General electrical drives

Options

- Combinable with the switching rectifier SGL in overexcitation mode
- Combinable with bridge rectifier BGL-PE400/150/3
- Combinable with half-wave rectifier EGL-PE400/150/3

Method

The Brake Control Unit BCU 2001 records characteristic current and voltage variations, which are induced by movements of the armature disk in the magnetic field of the brake coil. In an interference free and reliable manner it evaluates the signal levels in terms of the control state (applied or released) and the maximum air gap (maximum wear)

Important requirements

- AC and DC circuit to be switched simultaneously
- AC circuit may not be switched alone

Brake Control Unit BCU2001

Principal circuit diagram



Rev. 07-17

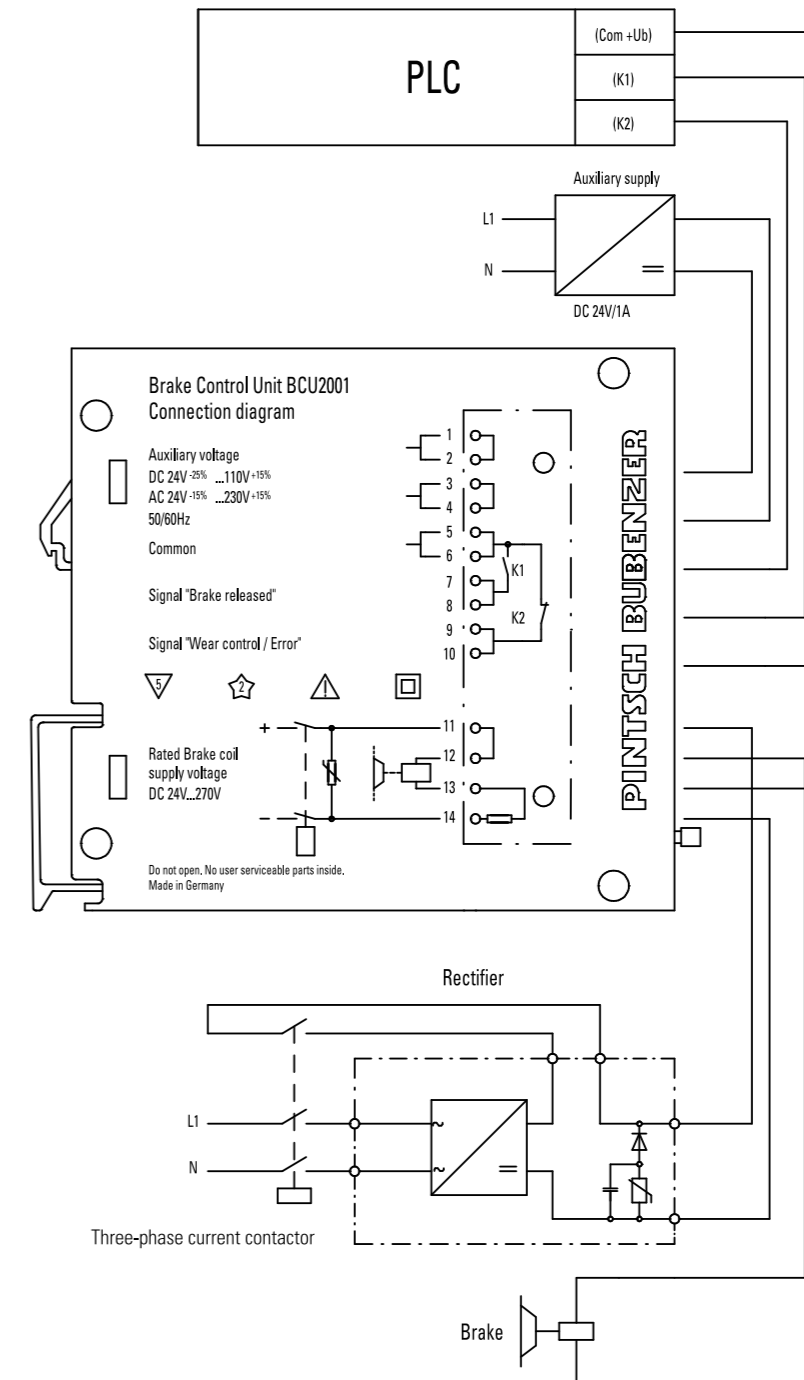

Technical data

Permissible coil voltages:	DC 24V ... 396V
Ambient temperature:	-40° C ... +50° C
Protection class:	IP 20
Permissible auxiliary power supplies:	AC 24 V -15% ... AC 230 V +15% DC 24 V -25% ... DC 110 V +15%



Please Note

We supply a detailed operating manual with every order. Nevertheless, we would point out that brakes are only as safe as the servicing and maintenance performed while they are in operation. The guarantee for the correct functioning of our brakes is only valid if the user adheres to the German DIN standard 15434 part 2 (drum and disc brakes, servicing and maintenance in operation), or to comparable standards in his own country.



PINTSCH BUBENZER Service

This includes the verification of the brake selection, if required. A detailed questionnaire is provided for this purpose. Installation and commissioning on-site by PINTSCH BUBENZER service engineers is possible. Drawings as DWG/DXF files for your engineering department are available upon request.

Description Brake Control Unit BCMS-4



Main Features

- Plug and play – minimal configuration and implementation effort
- No micro- or proximity switches required for the brake (much lower amount of wiring)
- Components such as contactors, power rectifier, suppressor to be omitted (space and cost savings)
- Through the use of plug-in terminals a prior installation of the connecting cables is possible (saves time)
- Normal maintenance intervals are not required on our brakes (extreme reduction of maintenance costs)
- Due to the 4-channel version up to four spring-loaded brakes can be operated simultaneously
- Certified safety through professional association
- In conjunction with a superior safety PLC operation by security classification DIN EN ISO 13849-1 PL d, Cat 3 is possible
- Internal 2-channel safety logic in redundant design
- Providing I / O diagnostic outputs for integration into PLC
- Quick releasing and closing of the brakes
- Overcurrent trip to protect the brakes
- Wire break recognition
- Minimize the power dissipation of the brakes by regulation the holding current
- Internal menu structure

- Representation of the status wear
- User interface RS 232 for connection and intervention in the menu structure
- Manual operation of the menu structure
- The operating status and diagnostic messages are be visualized and displayed at the unit itself
- Optimization of the wear allowance
- „One solution, one source“

Applications

- Container cranes
- Ship winches
- Automatic racking systems
- Conveyor belts
- General electrical drives

Method

The BCMS-4 is a micro-controller-based monitoring and switching device for spring applied brakes of the SFB and KFB series. Through measurement and analysis of current and voltage of the outgoing two-wire lines of the individual brakes wear and switching state of each electromagnetic spring-applied brake can be detected in some distant mounting position. There can be up to four brakes operated and evaluated simultaneously. The operation of the brakes is fundamentally with rapid releasing and closing of the brakes.

Brake Control Unit BCMS-4

Principal circuit diagram



Rev. 11-11

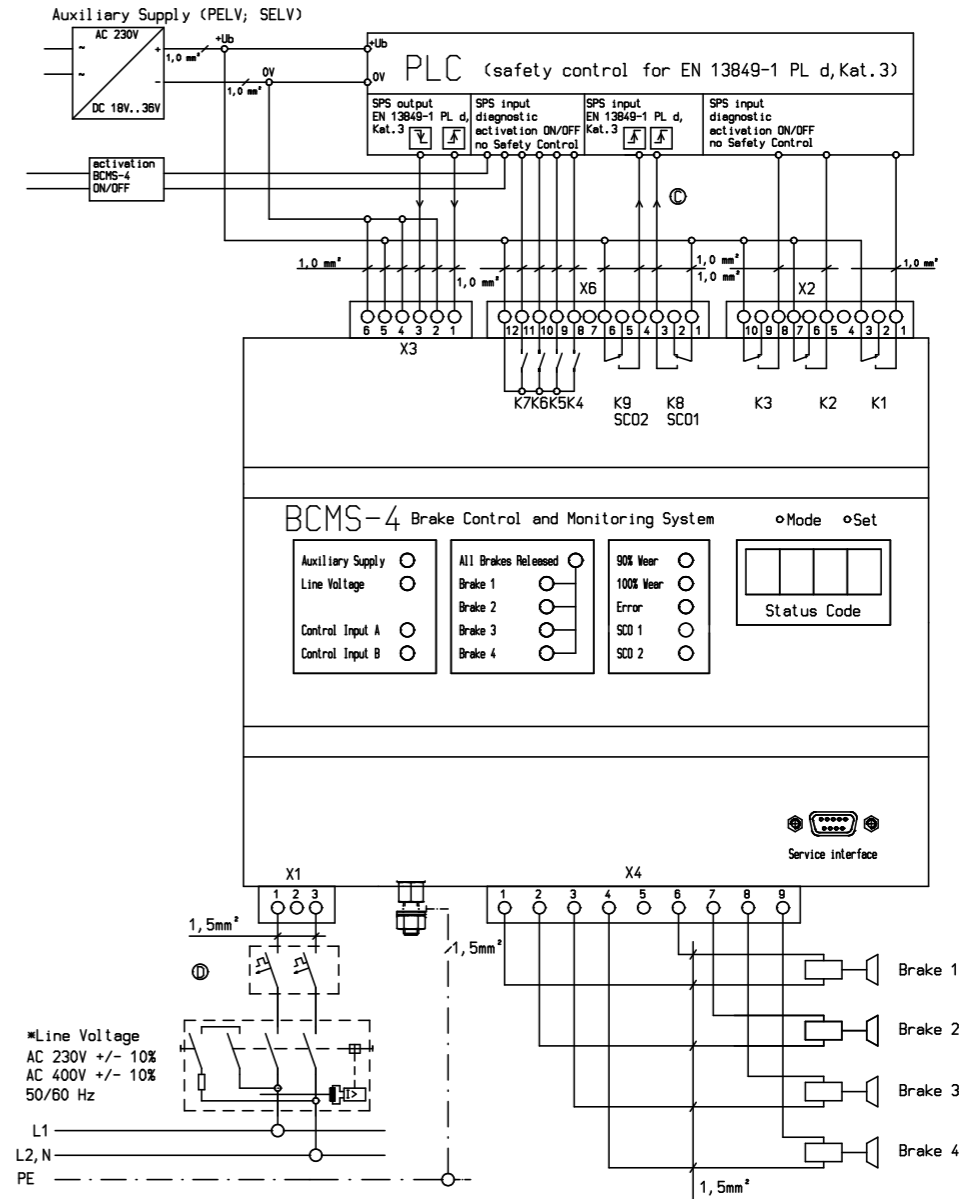

Technical data

Permissible auxiliary power supplies:	AC 230V +/- 10%; 50/60 Hz AC 400V +/- 10%; 50/60 Hz
Ambient temperature:	-30°C ... +50°C
Protection class:	IP 20
Permissible coil voltages:	110 V DC and 207 V DC
security rating:	DIN EN ISO 13849-1 PL d, Cat 3
PFHD:	1.16 ⁻⁷



Please Note

We supply a detailed operating manual with every order. Nevertheless, we would point out that brakes are only as safe as the servicing and maintenance performed while they are in operation. The guarantee for the correct functioning of our brakes is only valid if the user adheres to the German DIN standard 15434 part 2 (drum and disc brakes, servicing and maintenance in operation), or to comparable standards in his own country.



PINTSCH BUBENZER Service

This includes the verification of the brake selection, if required. A detailed questionnaire is provided for this purpose. Installation and commissioning on-site by PINTSCH BUBENZER service engineers is possible. Drawings as DWG/DXF files for your engineering department are available upon request.

Disc Brake SB 17 MX Series

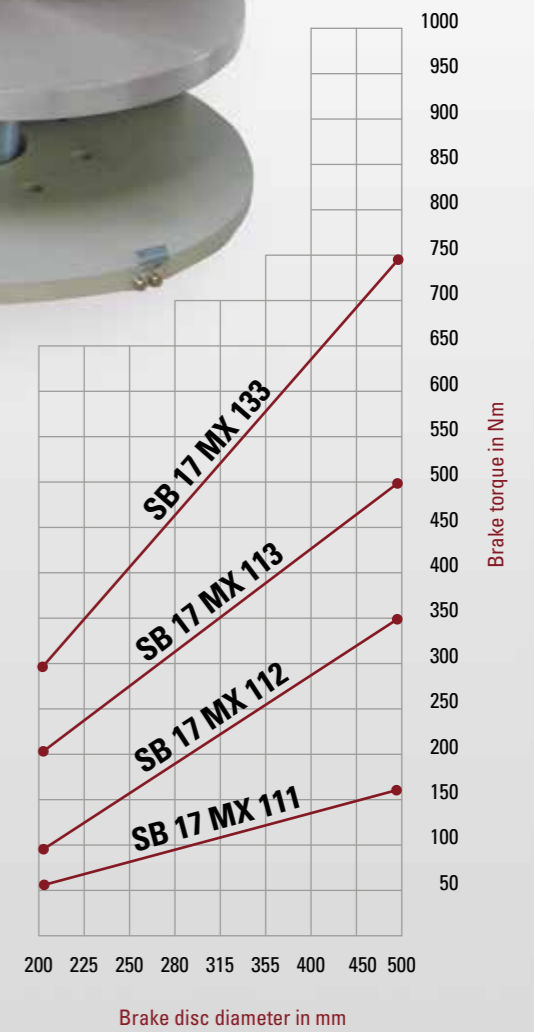

PINTSCH BUBENZER
is certified according to
DIN EN ISO 9001:2015



Compact Design

High Performance

Low Maintenance

Reliable

Description SB 17 MX



Main Features

- Electromagnetic release
- High performance by overforcing of electromagnet (magnet IP54)
- Internal rectifier / economizer unit, direct connection to 380-480 V AC, 3 Ph., 50-60 Hz
- Adjustable brake torque
- Simple, manual wear compensation
- Organic, non-asbestos linings
- Manual release and limit switch release control as a standard
- Stainless steel brake body

Options

- Limit switch wear control
- Sintered linings
- Hydraulic damping unit for continuously adjustable apply time of 1-8 seconds
- Motor connection flange incl. protective cover
- Brake discs with hubs or couplings

Applications

- The capacity of these brakes makes them particularly suitable as service brakes e.g. on crane gantries, slewing drives or smaller hoists
- In combination with the hydraulic damping unit, a soft and smooth braking is possible
- Very compact and easy to install as a motor mounted version

Magnets, Technical Data

Magnet Type	Inrush (W)	Holding (W)
111	100	100
112	360	100
113	360	100
133	360	100

Ordering Example

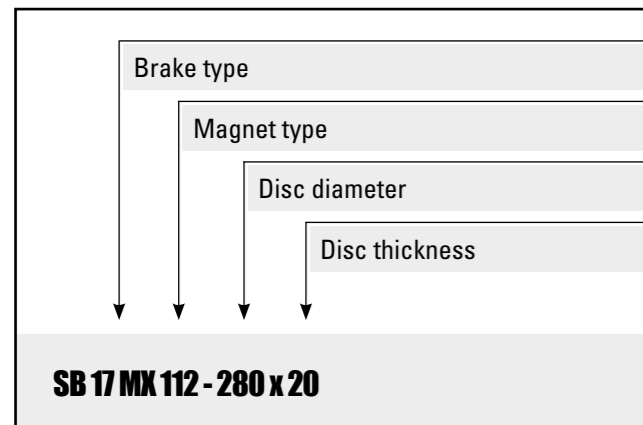

Disc Brake SB 17 MX

Dimensions and technical data



Rev. 12-06

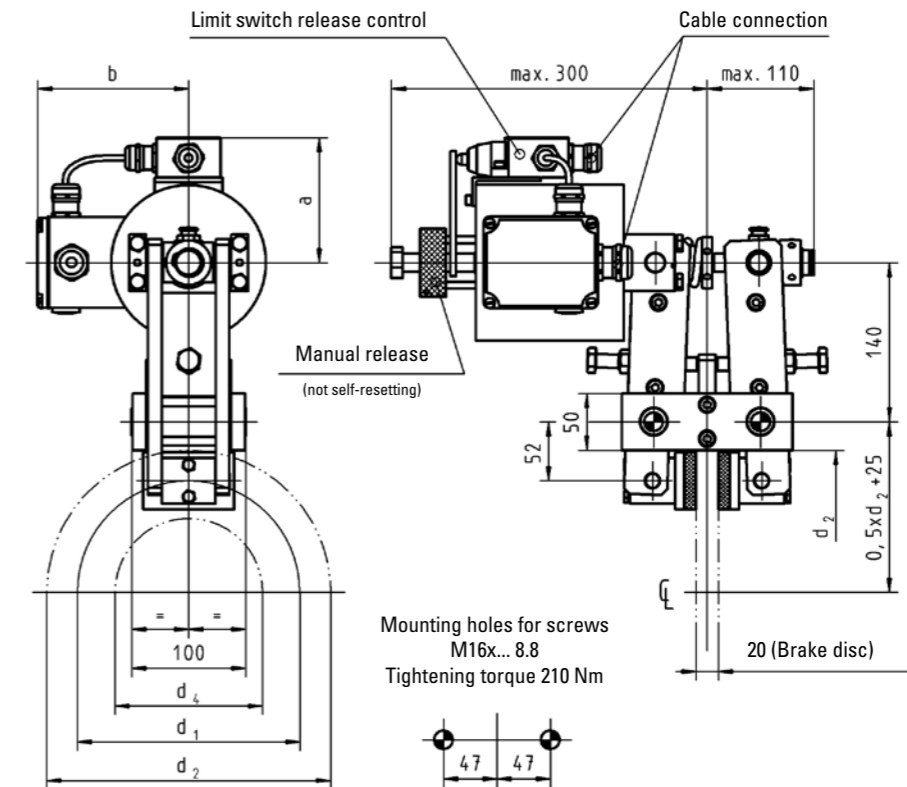

Type	Magnet dimensions			Lining
	a	b	Øc	b2
111	105	120	114	40
112	105	120	114	40
113	105	120	114	50
133	115	133	137	50

*) Average static friction factor of standard material combination

All dimensions in mm
Alterations reserved without notice

For crane brake layout use safety factors documented in the FEM 1.001, Section 1

Disc Ø	Friction Ø	Hub Ø max.	Magnet type			
			111	112	113	133
d ₂	d ₁	d ₄	Contact force in N			
			1100	2150	3150	4200
			Brake torque M _{Br} in Nm		Friction factor μ = 0,4*	
200	146	80	60	130		
225	171	105	70	150		
250	196	130	85	170	250	
280	226	160	100	195	285	375
315	261	195	115	225	330	440
355	301	235			375	500
400	346	280			435	580
450	396	330				665
500	446	380				750



Please Note

We supply a detailed operating manual with every order. Nevertheless, we would point out that brakes are only as safe as the servicing and maintenance performed while they are in operation. The guarantee for the correct functioning of our brakes is only valid if the user adheres to the German DIN standard 15434 part 2 (drum and disc brakes, servicing and maintenance in operation), or to comparable standards in his own country.



PINTSCH BUBENZER Service

This includes the verification of the brake selection, if required. A detailed questionnaire is provided for this purpose. Installation and commissioning on-site by PINTSCH BUBENZER service engineers is possible. Drawings as DWG/DXF files for your engineering department are available upon request.

Disc Brake SB 17 MXs

with hydraulic damping unit – Dimensions and technical data



Rev. 12-06

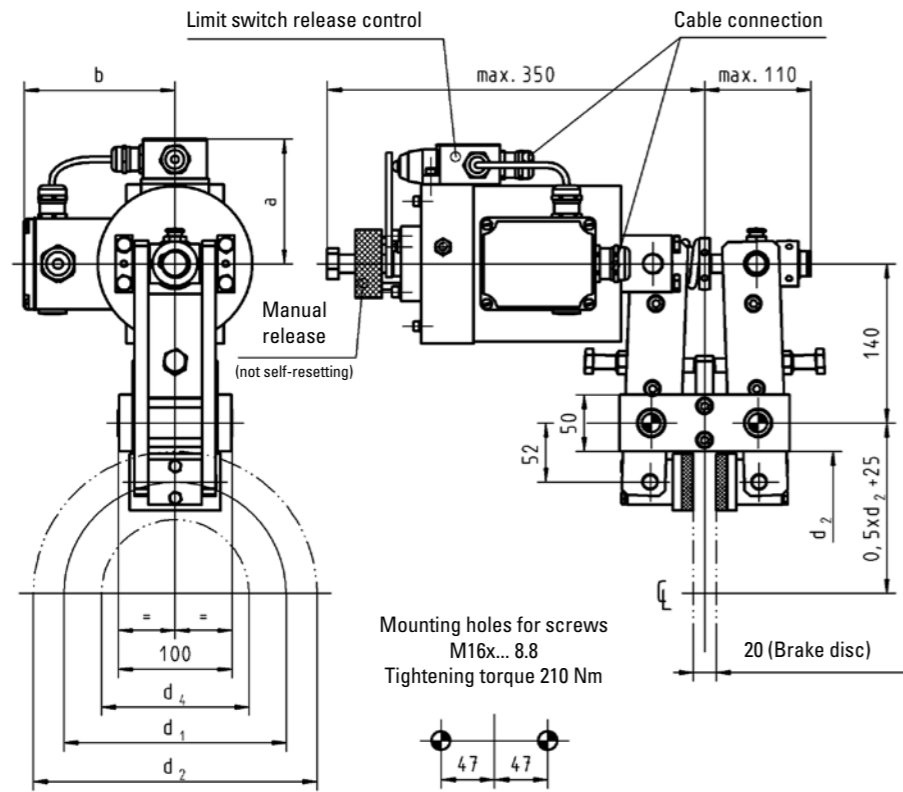

Magnet dimensions				Lining
Type	a	b	Øc	b2
111	105	120	114	40
112	105	120	114	40
113	105	120	114	50
133	115	133	137	50

Apply time adjustable 1...8 seconds

*) Average static friction factor of standard material combination

All dimensions in mm
Alterations reserved without notice

For crane brake layout use safety factors documented in the FEM 1.001, Section 1

Weight: 26 kg max. incl. magnet		Magnet type		
		112	113	133
		Contact force in N		
Disc Ø	Friction Ø	Hub Ø max.		
d2	d1	d4		
		Brake torque M _{Br} in Nm	Friction factor μ = 0,4*	
200	146	58		
225	171	68	102	
250	196	78	117	235
280	226	90	135	270
315	261	104	155	310
355	301		180	360
400	346		207	415
450	396			475
500	446			535

Disc Brake SB 17 MX

Connecting diagram internal rectifier/economizer



Rev. 07-14

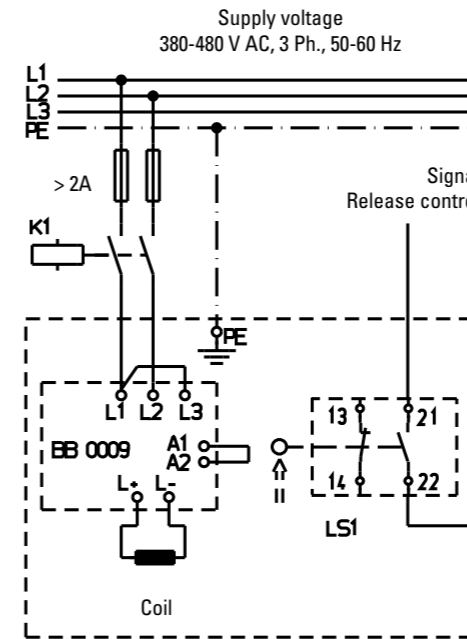

SB 17 MX 111

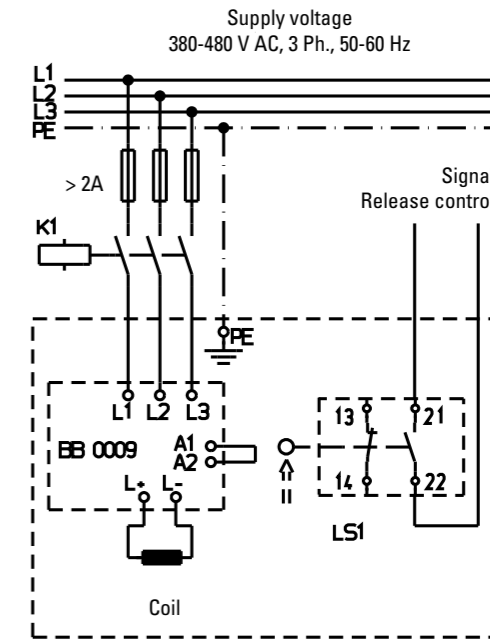

SB 17 MX 112/113/133

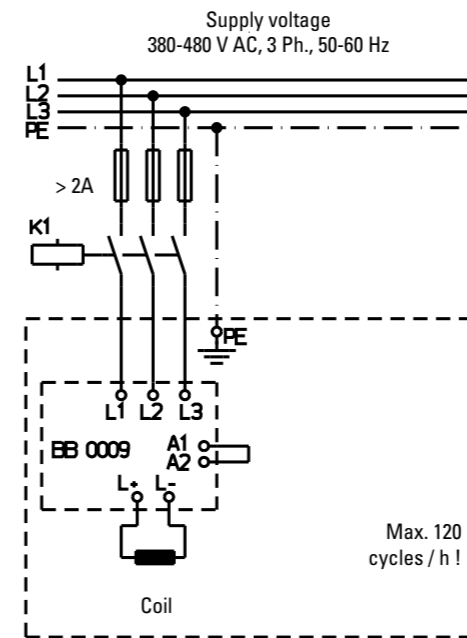

SB 17 MX without limit switch release control

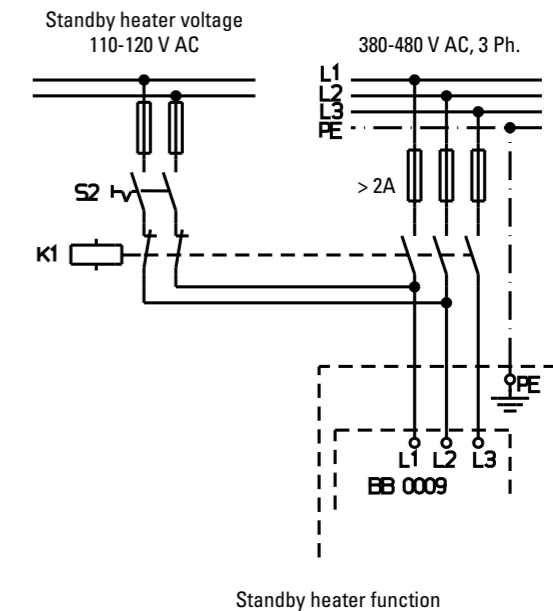

Standby heater function

Alterations reserved without notice

Supply voltage	Coil voltage
380-415 V AC	180 V DC
440-480 V AC	205 V DC

PINTSCH BUBENZER scope of supply:
SB 17 MX, coil
Rectifier / economizer BB0009 (built-in)
Limit switch LS1

Disc Brake SB 17 MX

Installation example, motor mounted version



Rev. 12-06

Brake mountable in each 45° steps

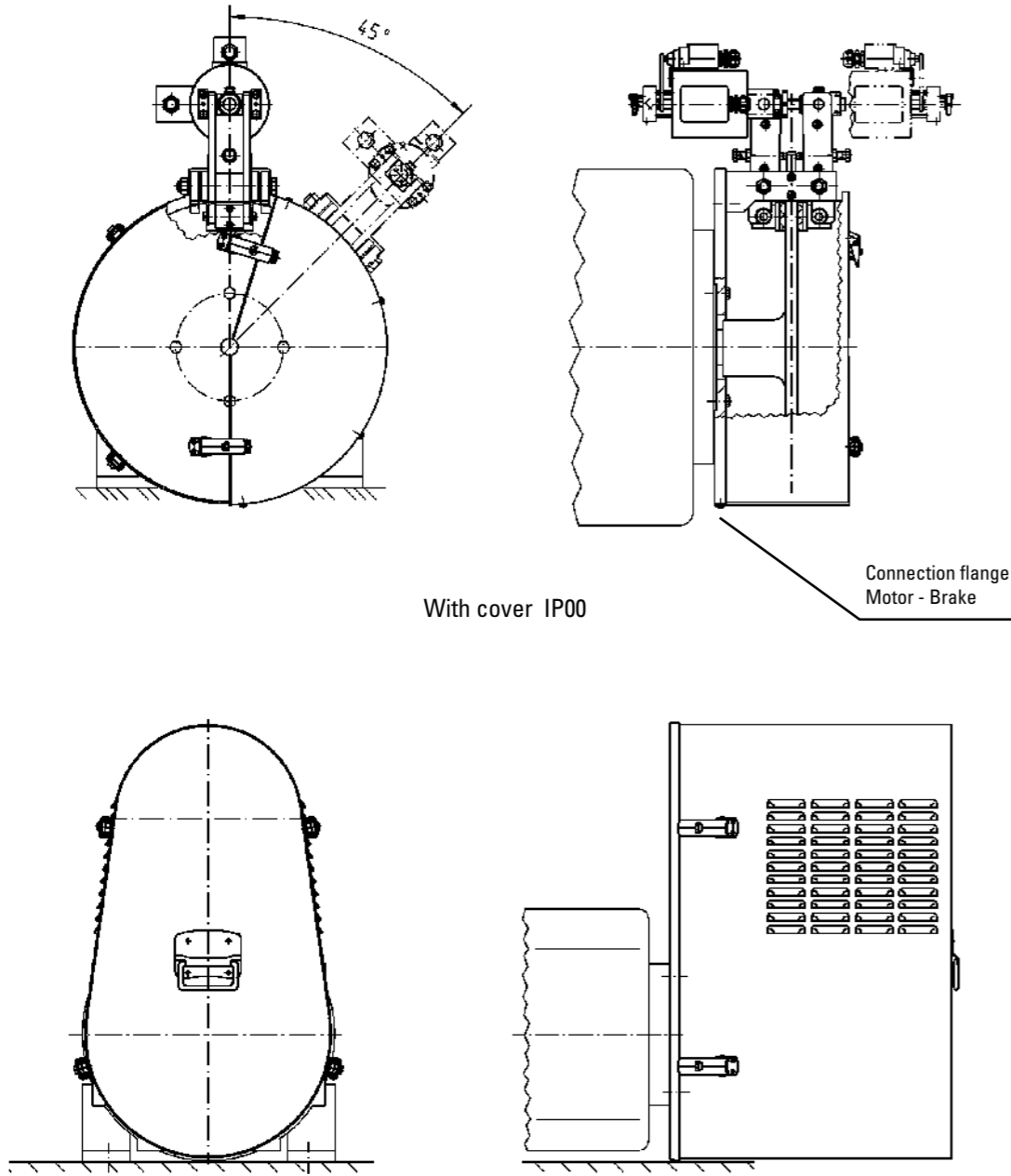

With cover IP00

With cover IP22

When placing order, please indicate motor type.

Drum Brakes



Brake drum diameter (mm)	EBH Brake torque (Nm)	EBN Brake torque (Nm)
200	~50	~100
250	~100	~200
315	~150	~300
400	~200	~400
500	~300	~500
630	~400	~600
710	~500	~700

PINTSCH BUBENZER
is certified according to
DIN EN ISO 9001:2015



Acc. to DIN 15435



High Performance



Reliable



Robust Design



Tried and Trusted

Description Drum Brakes



Main Features

- According to DIN 15435 standard
- Continuously adjustable brake spring enclosed in a square tube with torque scale
- Self-lubricating bushings mean brakes are easy to service, no greasing necessary
- Equal air gap by adjustable lever stops
- Up to size 400:
Levers and base plate made of nodular cast iron
- From size 500:
Levers and base plate made of welded steel
- Different thrusters
- Aluminum brake shoes acc. DIN 15435 Bl. 2 with non-asbestos, organic linings
- Shoe clamping springs which prevent brake shoes from tilting when released
- Pins and main spindle of stainless steel
- Uncoated parts and screws of stainless steel

Options

- Automatic wear compensator
- Limit switch release control
- Limit switch wear control
- Limit switch manual release
- Manual release lever with or w/o stop
- Monitoring systems (e.g. VSR/CMB)
- Brake drums with hubs or couplings
- Weather execution (special paint and coating) for outdoor use

Thrusters, Technical Data

Thruster Type	Power (W)	Curr. (A) at 400 V	Weight (kg)
BL 22-5	150	0,4	11
BL 30-5	160	0,4	13
BL 50-6	450	0,7	16
BL 80-6	600	1,3	21
BL 125-6	650	1,4	24
BL 200-6	800	1,5	24

Protection: max. 1.5 times of nominal current

Drum Brake Type EBN

Dimensions and technical data



Rev. 04-17

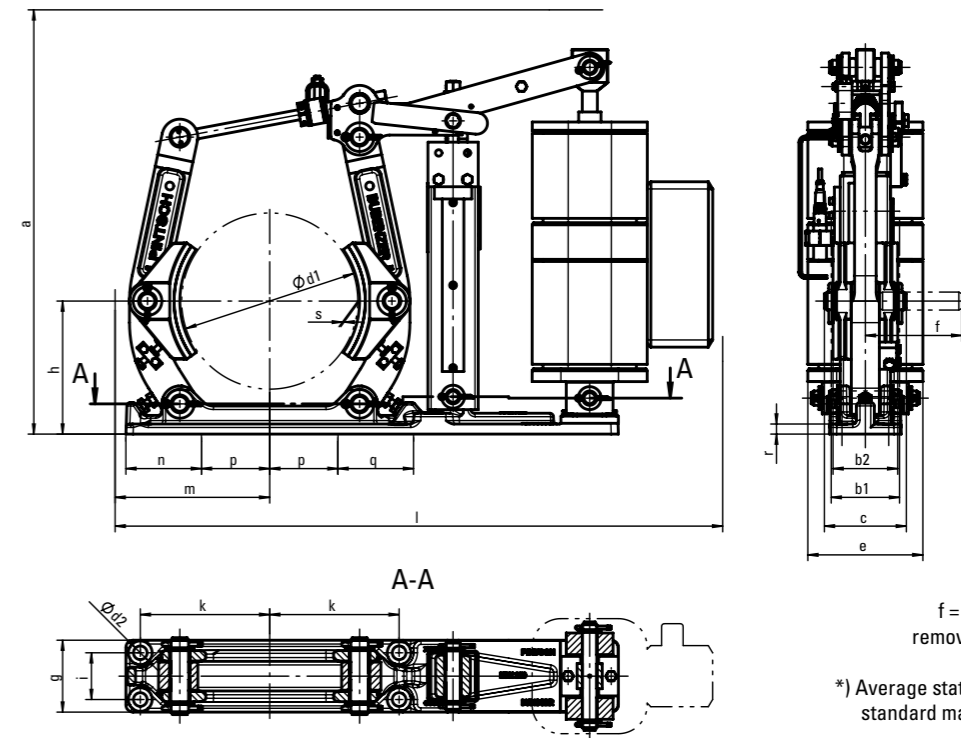

f = required space for removing brake shoe pin

*) Average static friction factor of standard material combination

All dimensions in mm
Alterations reserved without notice

The friction coefficient is subject to fluctuations depending on operational-, material- and ambient-conditions! This must be considered during the selection!

Brake type	Thruster type	*M _{Brmax.} (Nm) at μ = 0,4	*M _{Brmin.} (Nm) at μ = 0,4	*M _{Brmin.} (% from M _{Brmax.})	a _{max.}	b ₁	b ₂	c	d ₁	d ₂	e	f ca.	g	h	i	k	l _{max.}	m ca.	n	p	q	r	s ca.	kg ca.
EBN 200-22-5	BL 22-5	325	195	60	510	75	70	96	200	15	160	115	90	155	55	145	675	185	100	70	100	12	1	41
EBN 200-30-5	BL 30-5	420	210	50	563	75	70	96	200	15	160	115	90	155	55	145	680	185	100	70	100	12	1	45
EBN 200-50-6	BL 50-6	600	360	60	573	75	70	96	200	15	160	115	90	155	55	145	720	185	100	70	100	12	1,2	46
EBN 250-22-5	BL 22-5	450	225	50	518	95	90	115	250	19	160	135	100	185	65	180	800	215	105	95	105	14	1	47
EBN 250-30-5	BL 30-5	560	392	70	581	95	90	115	250	19	160	135	100	185	65	180	805	215	105	95	105	14	1	51
EBN 250-50-6	BL 50-6	1000	550	55	590	95	90	115	250	19	160	135	100	185	65	180	845	215	105	95	105	14	1,2	52
EBN 250-80-6	BL 80-6	1200	600	50	590	95	90	115	250	19	160	135	100	185	65	180	845	215	105	95	105	14	1,2	57
EBN 315-30-5	BL 30-5	700	420	60	703	118	110	140	315	19	160	165	110	225	80	220	920	270	110	133	240	14	1	81
EBN 315-50-6	BL 50-6	1400	770	55	705	118	110	140	315	19	160	165	110	225	80	220	1000	270	110	133	240	14	1,2	82
EBN 315-80-6	BL 80-6	2500	1250	50	705	118	110	140	315	19	160	165	110	225	80	220	1000	270	110	133	240	14	1,2	87
EBN 400-50-6	BL 50-6	1225	735	60	705	150	140	167	400	23	160	195	140	270	100	270	1105	315	135	165	280	15	1,4	98
EBN 400-80-6	BL 80-6	3000	1650	55	710	150	140	167	400	23	160	195	140	270	100	270	1105	315	135	165	280	15	1,4	103
EBN 400-125-6	BL 125-6	4000	2000	50	796	150	140	167	400	23	160	195	140	270	100	270	1105	315	135	165	280	15	1,4	106
EBN 500-50-6	BL 50-6	1500	750	50	851	190	180	210	500	22	160	245	170	330	130	325	1290	390	155	210	315	20	1,5	154
EBN 500-80-6	BL 80-6	3750	1875	50	851	190	180	210	500	22	160	245	170	330	130	325	1290	390	155	210	315	20	1,5	159
EBN 500-125-6	BL 125-6	5120	2560	50	851	190	180	210	500	22	160	245	170	330	130	325	1290	390	155	210	315	20	1,5	162
EBN 630-80-6	BL 80-6	3600	1800	50	995	236	225	250	630	27	160	300	220	410	170	400	1355	470	165	280	330	25	1,8	256
EBN 630-125-6	BL 125-6	5400	2700	50	1015	236	225	250	630	27	160	300	220	410	170	400	1355	470	165	280	330	25	1,8	259
EBN 630-200-6	BL 200-6	6025	3012	50	1015	236	225	250	630	27	160	300	220	410	170	400	1355	470	165	280	330	25	1,8	259
EBN 710-80-6	BL 80-6	4500	2250	50	1110	265	255	280	710	27	160	335	240	460	190	450	1515	520	250	250	450	25	1,8	331
EBN 710-125-6	BL 125-6	6000	3000	50	1110	265	255	280	710	27	160	335	240	460	190	450	1515	520	250	250	450	25	1,8	334
EBN 710-200-6	BL 200-6	6920	3460	50	1110	265	255	280	710	27	160	335	240	460	190	450	1515	520	250	250	450	25	1,8	334



Please Note

We supply a detailed operating manual with every order. Nevertheless, we would point out that brakes are only as safe as the servicing and maintenance performed while they are in operation. The guarantee for the correct functioning of our brakes is only valid if the user adheres to the German DIN standard 15434 part 2 (drum and disc brakes, servicing and maintenance in operation), or to comparable standards in his own country.



PINTSCH BUBENZER Service

This includes the verification of the brake selection, if required. A detailed questionnaire is provided for this purpose. Installation and commissioning on-site by PINTSCH BUBENZER service engineers is possible. Drawings as DWG/DXF files for your engineering department are available upon request.

Drum Brake Type PBNi

Brake release by pneumatic cylinder
Dimensions (DIN 15435) and technical data



Rev. 04-17

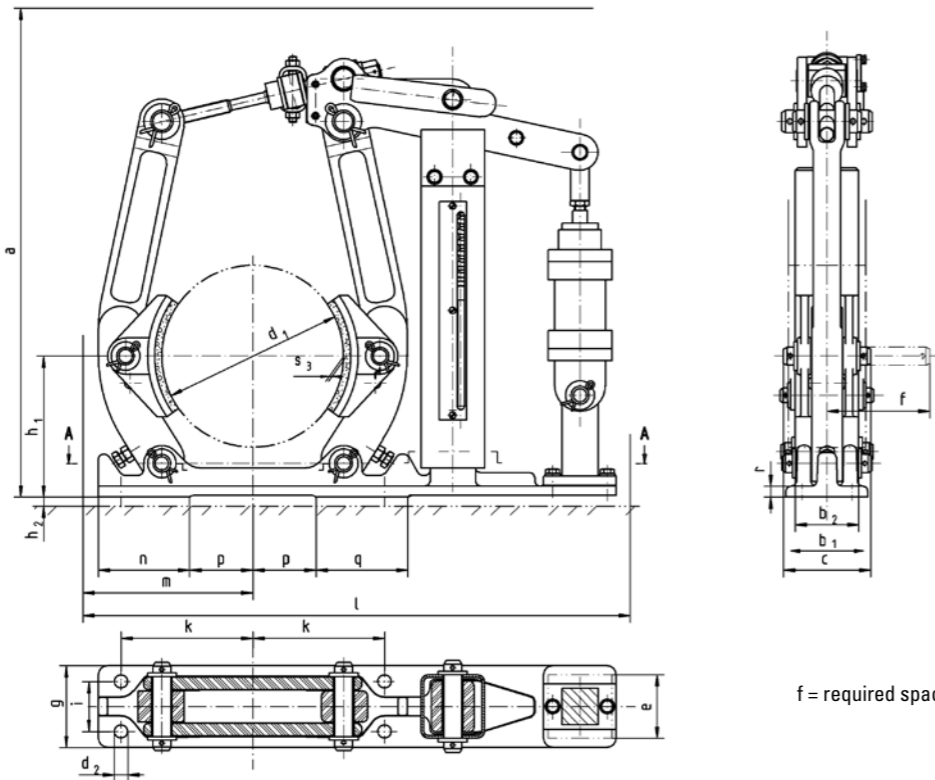

f = required space for removing brake shoe pin

*) Average static friction factor of standard material combination

All dimensions in mm
Alterations reserved without notice

Brake is available also as "pneumatic applied" version (PBNd, upon request)

Brake type	Operating pressure, bar	M _{BR} max. (Nm) at μ = 0,4*	a _{max}	b ₁	b ₂	c	d ₁	d ₂	e	f ca.	g	h ₁	h ₂	i	k	l _{max}	m ca.	n	p	q	r	s ca.	kg ca.
PBNi 200-30	6	365	500	75	70	96	200	14	50	115	90	155	5	55	145	590	185	100	70	100	12	1	22
PBNi 250-30	6	470	500	95	90	115	250	18	50	135	100	185	5	65	180	700	205	105	95	105	13	1,2	28
PBNi 250-40		65							710														
PBNi 315-40	6	1150	665	118	110	140	315	18	65	165	110	225	5	80	220	900	300	110	133	240	13	1,2	47
PBNi 315-50		70							910														
PBNi 400-50	6	2000	680	150	140	167	400	22	70	195	140	270	10	100	270	965	310	135	165	280	15	1,5	82
PBNi 400-60		80							975														
PBNi 500-50	6	2950	830	190	180	210	500	22	70	245	170	330	10	130	325	1120	370	155	210	315	20	1,5	122
PBNi 500-60		80							1130														
PBNi 500-80		100							1150														
PBNi 630-60	6	4700	990	236	225	250	630	27	80	300	220	410	10	170	400	1230	450	150	280	170	25	2	196
PBNi 630-80		100							1250														
PBNi 630-100		124							1275														
PBNi 710-60	6	5300	1080	265	255	280	710	27	80	335	240	460	10	190	450	1445	520	150	335	175	25	2	266
PBNi 710-80		100							1445														
PBNi 710-100		124							1470														

Drum Brake EBN-2St

Dimensions and technical data



Rev. 04-17

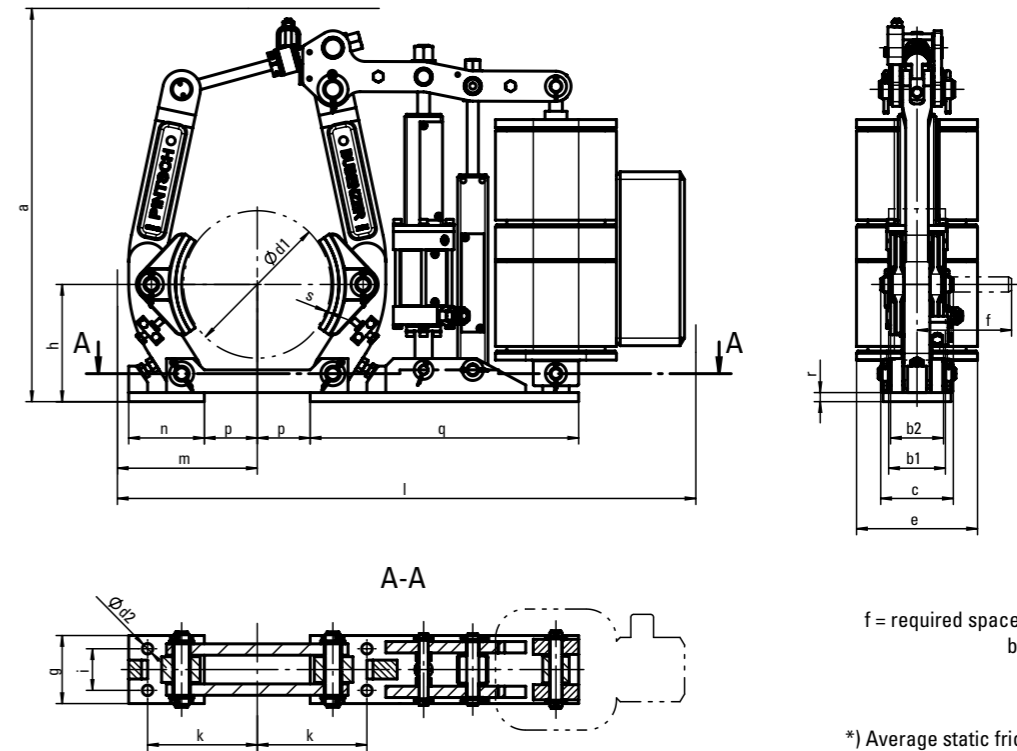

f = required space for removing brake shoe pin

*) Average static friction factor of standard material combination

The friction coefficient is subject to fluctuations depending on operational-, material- and ambient-conditions! This must be considered during the selection!

All dimensions in mm
Alterations reserved without notice

Brake type	Thruster type	M _{BR} max. (Nm) at μ = 0,4*	a _{max}	b ₁	b ₂	c	d ₁	d ₂	e	f ca.	g	h	i	k	l _{max}	m ca.	n	p	q	r	s ca.	kg ca.
EBN-2St 200-22-5	BL 22-5	140	520	75	70	96	200	14	160	115	90	155	55	145	730	185	100	70	350	12	1	36
EBN-2St 200-30-5	BL 30-5	230	520	75	70	96	200	14	160	115	90	155	55	145	735	185	100	70	350	12	1	38
EBN-2St 200-50-6	BL 50-6	360	563	75	70	96	200	14	160	115	90	155	55	145	765	185	100	70	350	12	1	41
EBN-2St 250-22-5	BL 22-5	180	520	95	90	115	250	18	160	135	100	185	65	180	880	205	105	95	405	13	1,2	42
EBN-2St 250-30-5	BL 30-5	290	520	95	90	115	250	18	160	135	100	185	65	180	885	205	105	95	405	13	1,2	44
EBN-2St 250-50-6	BL 50-6	530	582	95	90	115	250	18	160	135	100	185	65	180	925	205	105	95	405	13	1,2	47
EBN-2St 250-80-6	BL 80-6	720	582	95	90	115	250	18	160	135	100	185	65	180	925	205	105	95	405	13	1,2	52
EBN-2St 315-30-5	BL 30-5	420	665	118	110	140	315	18	160	165	110	225	80	220	1035	300	110	133	430	13	1,2	63
EBN-2St 315-50-6	BL 50-6	650	665	118	110	140	315	18	160	165	110	225	80	220	1115	300	110	133	430	13	1,2	66
EBN-2St 315-80-6	BL 80-6	1190	665	118	110	140	315	18	160	165	110	225	80	220	1115	300	110	133	430	13	1,2	71
EBN-2St 315-125-6	BL 125-6	1500	790	118	110	140	315	18	160	165	110	225	80	220	1115	300	110	133	430	13	1,2	74
EBN-2St 400-50-6	BL 50-6	760	680	150	140	167	400	22	160	195	140	270	100	270	1195	310	135	165	500	15	1,5	104
EBN-2St 400-80-6	BL 80-6	1400	680	150	140	167	400	22	160	195	140	270	100	270	1195	310	135	165	500	15	1,5	109
EBN-2St 400-125-6	BL 125-6	2120	790	150	140	167	400	22	160	195	140	270	100	270	1205	310	135	165	500	15	1,5	112
EBN-2St 400-200-6	BL 200-6	2500	790	150	140	167	400	22	160	195	140	270	100	270	1205	310	135	165	500	15	1,5	112
EBN-2St 500-50-6	BL 50-6	960	845	190	180	210	500	22	160	245	170	330	130	325	1285	370	155	210	315	20	1,5	144
EBN-2St 500-80-6	BL 80-6	1770	845	190	180	210	500	22	160	245	170	330	130	325	1285	370	155	210	315	20	1,5	149
EBN-2St 500-125-6	BL 125-6	2680	845	190	180	210	500	22	160	245	170	330	130	325	1295	370	155	210	315	20	1,5	152
EBN-2St 500-200-6	BL 200-6	4350	845	190	180	210	500	22	160	245	170	330	130	325	1295	370	155	210	315	20	1,5	152

Drum Brake Type EBN-2 St

as 2-step brake – Functional description



Rev. 09-02

Two directions are becoming apparent today in the use of double shoe brakes - apart from lifting gear brakes:

First of all, the use as a straight stopping brake and secondly as a brake for markedly special applications.

The 2-step brake offers exceptional possibilities in this area of special tasks.

This type designation is to be understood as covering brakes which:

- a) act with an adjustable partial torque A immediately after the actuator is switched off and in which
- b) the remaining braking torque B takes effect in an adjustable manner and is delayed in time with regard to torque A.

Thus, the max. braking torque = torque A + torque B

To generate the braking torque, our 2-step brakes have two spring systems fitted with pressure springs which act separately.

The spring 1 generating torque A, is firmly connected to the actuator (release) lever and is tensioned during the release movement. It is adjustable from about 20-50% of the maximum brake torque and takes effect after the actuator is switched off during the normal engagement time.

The spring system 2 generating torque B, is also tensioned during the release movement, generates 30-70% of the maximum braking torque and is firmly connected to a small hydraulic system.

Spring 2 is not firmly connected to the actuator lever; the spring and piston rod moves between two stops in a guide bushing in a crosspiece connected to the actuator lever.

When the actuator is switched off, the brake engages through the action of spring 1. Spring 2 must first displace oil in the hydraulic system through a choke adjustable from the outside before the braking torque generated by it can take effect.

The delaying hydraulic system is the heart of the 2-step brake. It is a small, compact, self-contained system without an external bypass, without an expansion tank. The piston is carried on bearings at both ends, the seals are teflon elements of a new type which reduce friction and the slip-stick effect to a minimum in comparison with usual sleeves and allow a hydraulic system to be used also in brakes with small actuators. The adjustment screw for the throttle valve is easily accessible and protrudes only slightly beyond the housing. The delay can be adjusted from 1 to about 12 seconds.

Filling medium is a special oil.

The whole system is extremely simple and robust, without easily damaged valves. It is easy to fill and to bleed, and consequently meets the basic requirement, also for small maintenance enterprises without specialists, of being clearly arranged, adjustable and capable of repair.

The hydraulic system can be used in all positions, horizontally or vertically.

Range of applications:

In particular, these concern belt drives and crane slew ing gear. Also for braking operations in which the partial torque A is sufficient for normal soft braking but where the full braking torque A+B must be available later for stopping purposes as with certain crane travelling gear. Consideration must be given to effects of wind pressure.

When the time factor in the delay is set appropriately, inching is also possible without the torque B being applied.

Drum Brake Type MBN

Brake release by DC magnet

Dimensions (DIN 15435) and technical data



Rev. 04-17

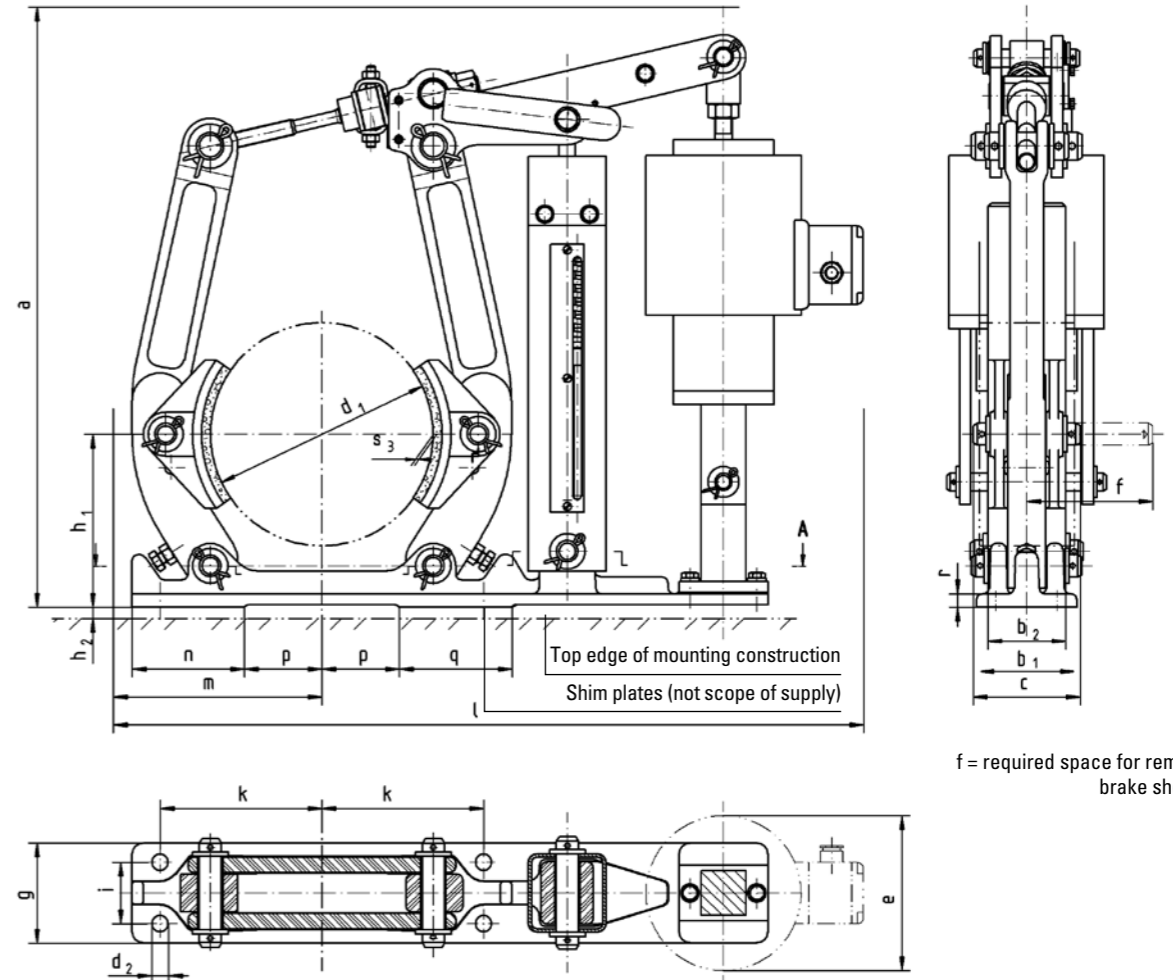

f = required space for removing brake shoe pin

*) Average static friction factor of standard material combination

All dimensions in mm
Alterations reserved without notice

Brake type	Magnet Type	M _{BR} max (Nm)		a _{max}	b ₁	b ₂	c	d ₁	d ₂	e	f ca.	g	h ₁	h ₂	i	k	l _{max}	m ca.		n	p	q	r	s ca.		kg ca.
		without forcing	with forcing																							
MBN 200-141	GH-141	120	420	563	75	70	96	200	14	140	115	90	155	5	55	145	670	185	100	70	100	12	0,8	22		
MBN 250-141	GH-141	145	535	572	95	90	115	250	18	140	135	100	185	5	65	180	790	205	105	95	105	13	1	28		
MBN 250-160	GH-160	250	800							800																
MBN 315-141	GH-141	175	625	665	118	110	140	315	18	140	165	110	225	5	80	220	965	300	110	133	240	13	1	47		
MBN 315-160	GH-160	300	1015							975																
MBN 400-160	GH-160	310	1080	680	150	140	167	400	22	160	195	140	270	10	100	270	1055	310	135	165	280	15	1,2	82		
MBN 400-180	GH-180	495	1780							1065																
MBN 500-160	GH-160	360	1225	830	190	180	210	500	22	160	245	170	330	10	130	325	1190	370	155	210	315	20	1,2	122		
MBN 500-180	GH-180	620	2000							1200																

Drum Brake Type MBN

Rectifier and economizer unit BB17.106



Rev. 09-02

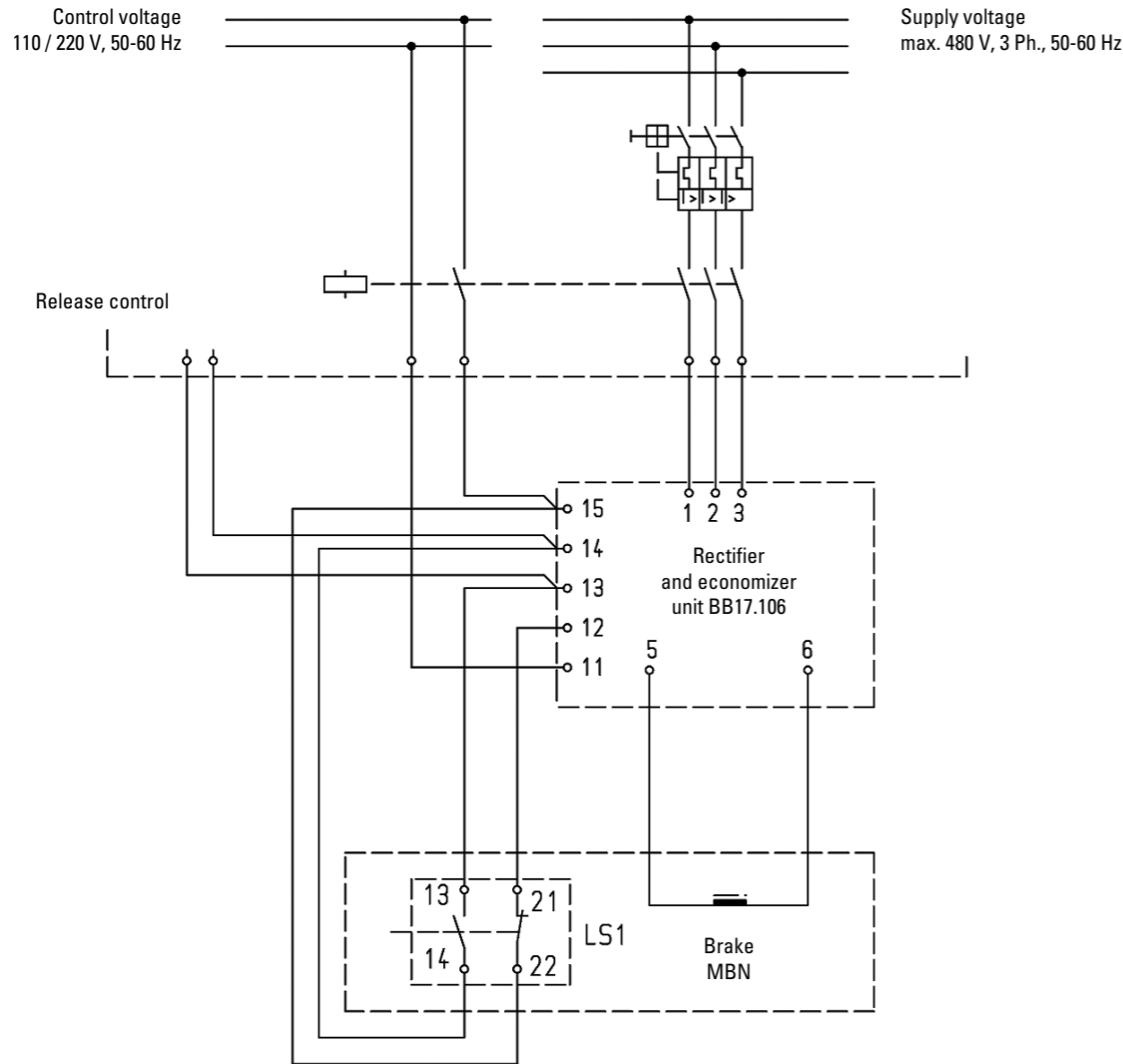

One brake can be connected to the BB17.106, but a rectifier and economizer unit type BB17.141 for the connection **of up to four** brakes is available as well. (Technical data for BB17.141 upon request)

Supply voltage:
Up to 480 V AC, 3 Ph, 50/60 Hz

Control voltage:
110-120 V AC or 220-240 V AC 50/60 Hz

The rectifier and economizer unit BB17.106 is available on circuit board or with enclosure IP65. Dimensions of the enclosure approx. 200 x 200 x 128 mm (W x H x D).

Range of applications:

The brake is released by forcing the solenoid for a short time to achieve higher forces. After the brake is fully released, the solenoid is supplied with a low holding voltage for continuous duty.

The switching back to holding voltage is done by the limit switch release control. Therefore, the limit switch release control is a necessary feature of the MBN drum brake.



To connect the MBN drum brake to AC voltage and in order to achieve higher braking torques, a rectifier and economizer unit type BB17.106 is required.

Drum Brake Type HBNdE

Dimensions (DIN 15435) and technical data



Rev. 04-17

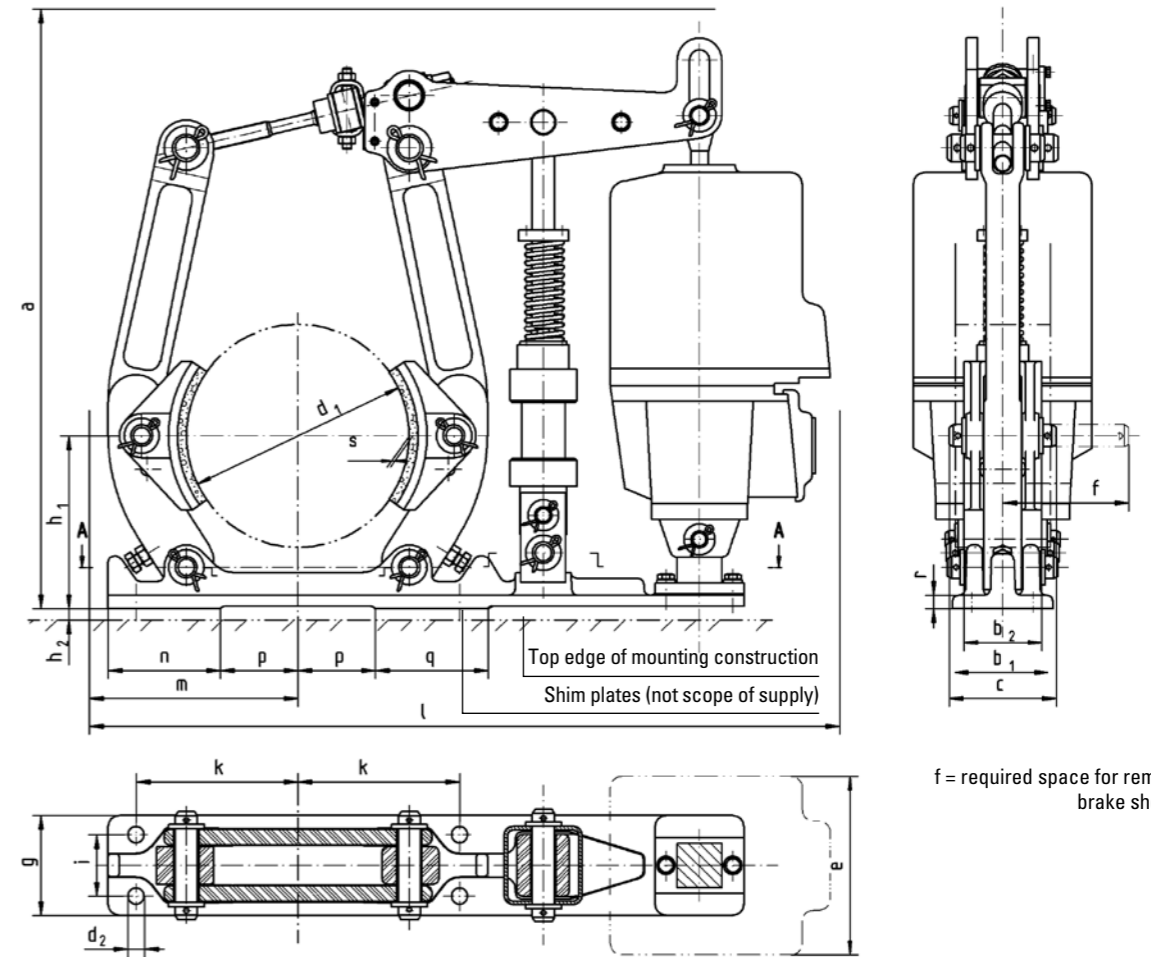

*) Average static friction factor of standard material combination

All dimensions in mm
Alterations reserved without notice

Brake type	Thruster type	Master cylinder type			M _{BR max} (Nm) $\mu = 0,4^*$																				
		31,75	25,4	Static torque	a _{max}	b ₁	b ₂	c	d ₁	d ₂	e	f ca.	g	h ₁	h ₂	i	k	l _{max}	m	n	p	q	r	s	kg ca.
		HBNde 200-23/5c	Ed 23/5c	200	200	80	550	75	70	96	200	14	160	115	90	155	5	55	145	665	185	100	70	100	12
HBNde 200-30/5c	Ed 30/5c	200	200	170	550													770	205	105	95	105	13	1,2	28
HBNde 250-23/5c	Ed 23/5c	280	550	100	550						160														
HBNde 250-30/5c	Ed 30/5c	280	550	180	550	95	90	115	250	18	160	135	100	185	5	65	180								
HBNde 250-50/6c	Ed 50/6c	280	550	350	560						195							810							
HBNde 315-23/5c	Ed 23/5c	350	700	150							160							920							
HBNde 315-30/5c	Ed 30/5c	350	700	320	660	118	110	140	315	18	160	165	110	225	5	80	220		300	110	133	240	13	1,2	47
HBNde 315-50/6c	Ed 50/6c	350	700	500							195							1000							
HBNde 315-80/6c	Ed 80/6c	350	700	750																					



The HBNdE releases and applies via thruster (with C-spring). The brake torque is not adjustable. Additionally, the brake can be applied by a hydraulic foot pedal. (Further sizes upon request.)

Drum Brake Type HBNd

Spring released, hydraulic applied (Foot pedal)
Dimensions (DIN 15435) and technical data



Rev. 03-16

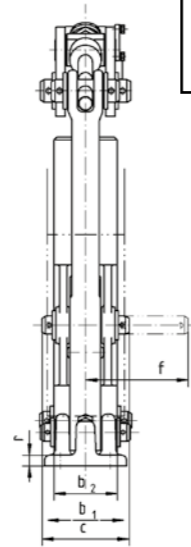
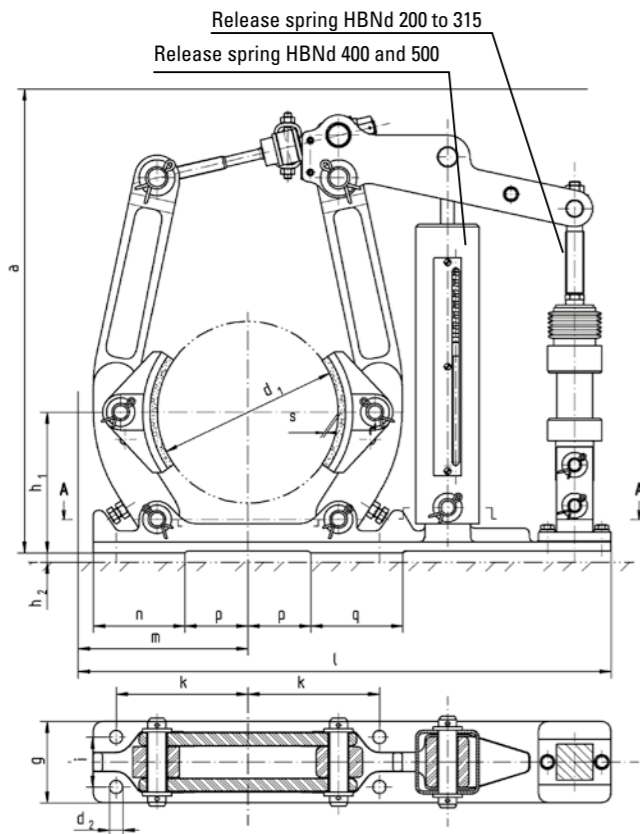

Brake is available also as "hydraulic released" version (HBNi, upon request)

f = required space for removing brake shoe pin

Execution consists of:

0	1 Brake 1 Foot pedal with simple main cylinder	31,75
1	consists of 2 Brakes 1 Foot pedal with simple main cylinder	31,75
2	consists of 2 Brakes 1 Foot pedal with step main cylinder	31,75 28,57

*) Average static friction factor of standard material combination

All dimensions in mm
Alterations reserved without notice

Brake type	Execution	M _{BR} max. (Nm) at μ = 0,4*	a _{max}	b ₁	b ₂	c	d ₁	d ₂	f ca.	g	h ₁	h ₂	i	k	l _{max}	m ca.	n	p	q	r	s ca.	kg ca.
HBNd 200-25	0	300	500	75	70	96	200	14	115	90	155	5	55	145	590	185	100	70	100	12	1	25
HBNd 200-25	1																					
HBNd 250-25	0	380	500	95	90	115	250	18	135	100	185	5	65	180	700	205	105	95	105	13	1,2	31
HBNd 250-25	1																					
HBNd 315-32	1	800	665	118	110	140	315	18	165	110	225	5	80	220	900	300	110	133	240	13	1,2	49
HBNd 315-25	2	900																				
HBNd 400-32	1	1050	680	150	140	167	400	22	195	140	270	10	100	270	965	310	135	165	280	15	1,5	84
HBNd 400-25	2	1170																				
HBNd 500-32	1	1300	830	190	180	210	500	22	245	170	330	10	130	325	1110	370	155	210	315	20	1,5	126
HBNd 500-32	2	1450																				

The calculated brake torques are based on a foot force of 150 N.

Foot Pedal

for hydraulic brakes



Rev. 09-02

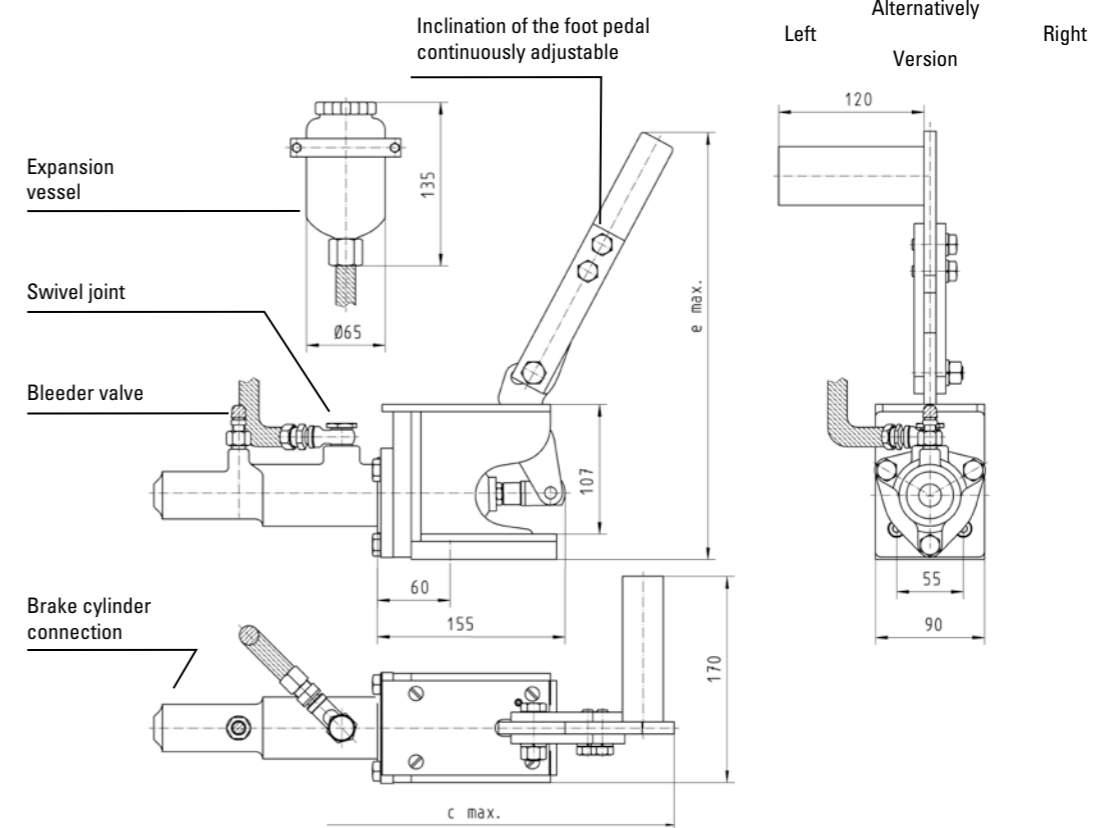

In order to operate two brakes synchronously by one foot pedal, the pipe connections from the foot pedal to each brake must be of the same length.

Scope of supply:

- a) Brake with built-in slave cylinder, bleeder valve and straight screw union for the connection of:
- b) One high-pressure hose, 500 mm long, with straight screw union, for connection to the pressure line.
- c) Expansion vessel with straight screw union.
- d) Foot pedal with attached master cylinder, a swivelling screw-fitting for the connection of the expansion vessel and a bleeder valve.
- e) Two high-pressure hoses, 300 mm long, for the connections of the master-cylinder pressure line and slave-cylinder pressure line to the expansion vessel. All the screw unions are arranged for pipe outer dia 10 mm. Pipes and other connection elements are not scope of supply but can be supplied if required.

Hydraulic foot pedal for the installation in cabin floors

Execution	a	b	c _{Max}	d	e _{Max}	Weight kg
1 with simple main cylinder	300	60	485	6	330	6,8
2 with two step cylinder	355	40	540	21	345	9,8

Piston Ø	ca. Pressure (at 150N foot force)
25,4	24 bar
28,5	18 bar
31,8	15 bar
38,0	10 bar

Please observe the notes on the following page for the piping and commissioning of the system.

Foot Pedal

Notes on the piping and commissioning



Rev. 09-02

General remarks:

Only brake fluid as specified in SAE J-1703e and DOT3 / DOT4 may be used. The use of even slight additions of hydraulic fluid or other mineral oils (residues in unclean pipework) leads, in every case, to the destruction of the seal elements and invalidates any guarantee granted by the manufacturer.

1) Master Cylinder

This cylinder may only be installed in a horizontal position, with connection on top for the expansion vessel (swivelling screw fitting). The high-pressure hose to the expansion vessel must not be kinked downwards but must be laid in a constantly ascending manner.

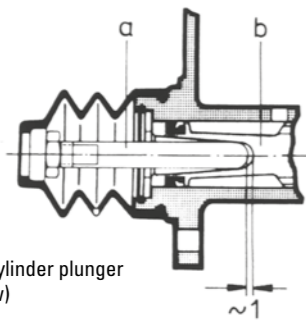

Master-cylinder plunger (part-view)

When actuated, the foot pedal is held by a pressure spring in the "off"-position against a stop, whereby there should be about 1 mm play between the plunger (a) and the top of the piston (b). This is to be taken into consideration if the factory setting of the stop has been disturbed.

2) Slave Cylinder (Brake)

Installation is possible in any position but the air bleed cock must always be arranged at the highest point. The slave cylinder is to be connected to the pressure line by the high-pressure hose supplied to allow movement of the cylinder when the brake is actuated.

3) Pipework

Material: Precision pipe as specified in DIN 2391, annealed and descaled. Dimensions dia. 10x1. Pipe bends are to be fabricated in a pipe bending device to avoid cross-sectional restrictions. After cutting to size and before laying, pipe sections are to be thoroughly flushed out (spirit) and blown through.

If possible, pressure lines are to be laid with a slight slope. If air pockets through ascending and descending loops cannot be avoided, a bleeding facility must be provided at the highest point.

4) High-pressure hoses

These hoses must be resistant to brake fluid. They must not be painted and are to be shielded from ambient heat.

5) Brake fluid

The brake fluid assures reliable operation down to -40°C. Depending on the quality, the wet boiling point (after water has been absorbed from the air) is between 140 and 155°C.

6) Filling and bleeding of the system

a) without filling and bleeding unit

Fill expansion vessel and in the subsequent filling and bleeding operation ensure that there is always sufficient fluid in the vessel by topping up. The air from the line to the master cylinder rises automatically when the line has been laid correctly. Press the foot pedal right down on the stop once or twice and with the pedal fully actuated first bleed the master cylinder. Close the bleeder valve.

Then open the valve at the slave cylinder (1-2 turns), fit transparent bleed tube and place other end in a receptacle. Pump foot pedal until air bubbles are no longer seen. At the same time, check the level of fluid in the expansion vessel to ensure that no air can be sucked in!

Close bleeder valve and actuate brake several times via the pedal. Then repeat bleeding procedure. The fluid pumped through during the bleeding procedure should not be reused.

b) with filling and bleeding unit (ATE, FAG or similar)

Small, moderately priced units are available on the market which can be connected to the expansion vessel and force the fluid under pressure through the system. Through the flexible separation of fluid and compressed air, the two elements cannot affect each other.

Advantage: The complete procedure can be carried out by one person only. Filling and bleeding will be quicker, safer and more straight forward. The filling and bleeding units come with operating instructions which must be followed exactly when working with such units.

Drum Brake Type EBH

Dimensions and technical data



Rev. 01-17

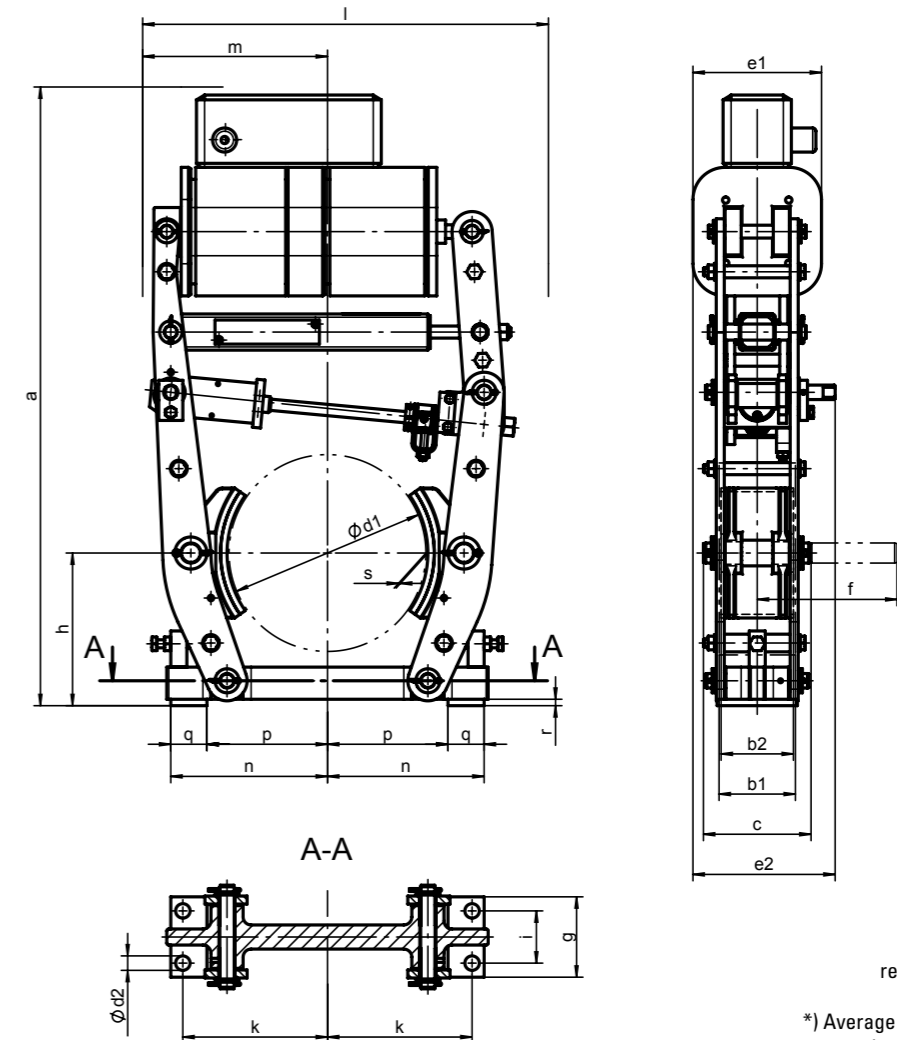

f = required space for removing brake shoe pin

*) Average static friction factor of standard material combination

All dimensions in mm
Alterations reserved without notice

The friction coefficient is subject to fluctuations depending on operational-, material- and ambient-conditions! This must be considered during the selection!

Brake type	Thruster type	*M _{Bmax.} (Nm) at μ = 0,4	*M _{Bmin.} (Nm) at μ = 0,4	*M _{Bmin.} (% from M _{Bmax.})	a _{max.}	b ₁	b ₂	c	d ₁	d ₂	e ₁	e ₂ ca.	f ca.	g	h	i	k	l _{max.}	m ca.	n	p	q	r	s ca.	kg ca.
EBH 200-22-5	BL 22-5	280	140	50	660	75	70	113	200	14	160	175	150	90	160	55	145	405	195	160	115	45	8	1	32
EBH 250-22-5	BL 22-5	305	153	50	730	95	90	134	250	18	160	180	180	100	190	65	180	455	225	195	150	45	8	1,2	38
EBH 250-30-5	BL 30-5	335	168	50	730	95	90	134	250	18	160	180	180	100	190	65	180	505	230	195	150	45	8	1,2	40
EBH 250-50-6	BL 50-6	510	255	50	770	95	90	134	250	18	160	185	180	100	190	65	180	600	270	195	150	45	8	1,5	43
EBH 315-22-5	BL 22-5	410	246	60	880	118	110	161	315	18	160	195	215	110	230	80	220	610	285	240	190	50	10	1,1	56
EBH 315-30-5	BL 30-5	490	245	50	880	118	110	161	315	18	160	195	215	110	230	80	220	610	285	240	190	50	10	1,1	58
EBH 315-50-6	BL 50-6	1050	577	55	920	118	110	161	315	18	160	195	215	110	230	80	220	615	290	240	190	50	10	1,4	66
EBH 315-80-6	BL 80-6	1120	560	50	920	118	110	161	315	18	160	195	215	110	230	80	220	615	290	240	190	50	10	1,4	72
EBH 400-50-6	BL 50-6	1000	500	50	1025	150	140	206	400	22	160	230	270	140	280	100	270	680	325	295	160	135	10	1,6	99
EBH 400-80-6	BL 80-6	2000	1000	50	1025	150	140	206	400	22	160	230	270	140	280	100	270	680	325	295	160	135	10	1,6	104
EBH 500-50-6	BL 50-6	1150	575	50	1130	190	180	245	500	22	160	270	330	170	340	130	325	840	420	355	275	80	12	1,7	138
EBH 500-80-6	BL 80-6	2200	1100	50	1130	190	180	245	500	22	160	270	330	170	340	130	325	840	420	355	275	80	12	1,7	143
EBH 500-125-6	BL 125-6	3500	1750	50	1140	190	180	245	500	22	160	270	330	170	340	130	325	900	425	355	275	80	12	1,7	150

Enclosures

For drum brakes type EBN – Dimensions and executions



Rev. 04-17

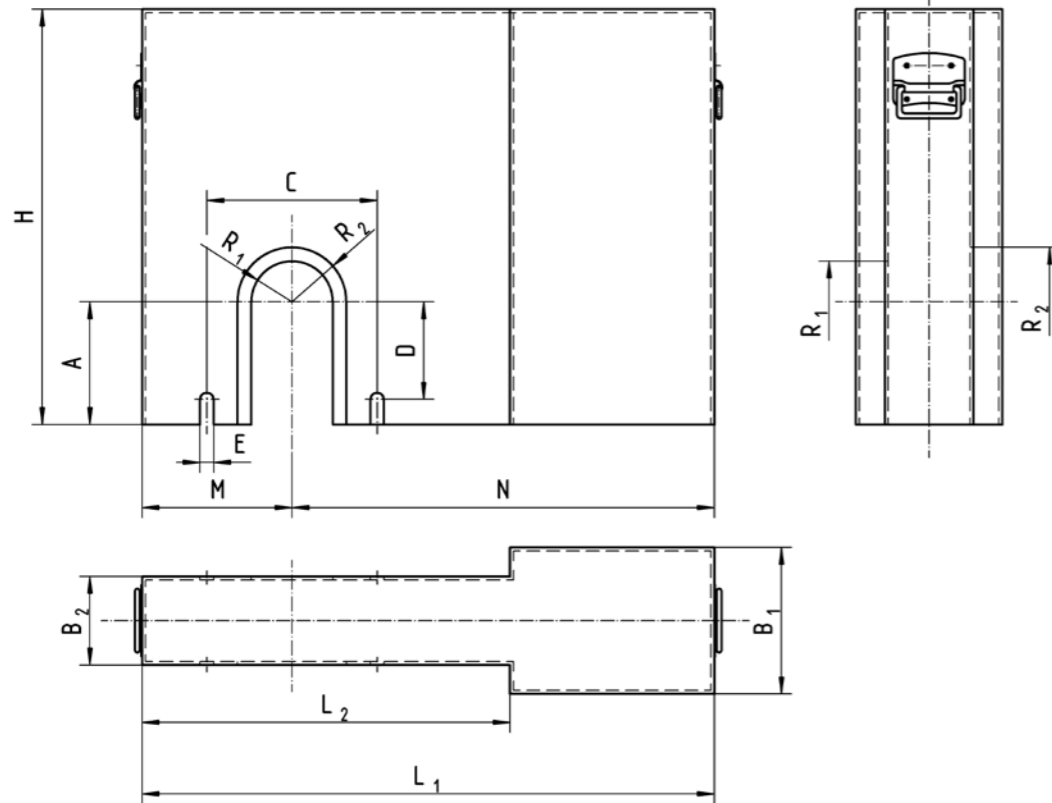

Plate thickness = 1,5 mm
 All enclosures are provided with handles
 Other dimensions upon request

All dimensions in mm
 Alterations reserved without notice

Brake type	A	B ₁	B ₂	C	D	E	H	L ₁	L ₂	M	N	R _{max}
EBN 200-22-5	150	180	130	200	118	10	530	710	460	195	515	90
EBN 200-30-5	150	180	130	200	118	10	530	710	460	195	515	90
EBN 200-50-6	150	180	130	200	118	10	580	750	440	195	555	90
EBN 250-22-5	180	180	130	250	143	10	530	820	560	220	600	110
EBN 250-30-5	180	180	130	250	143	10	610	820	560	220	600	110
EBN 250-50-6	180	180	130	250	143	10	610	860	540	220	640	110
EBN 250-80-6	180	180	130	250	143	10	610	860	540	220	640	110

When ordering please advise: Brake type, Dimension "R₁ and R₂"

Enclosures

For drum brakes type EBN – Dimensions and executions



Rev. 04-17

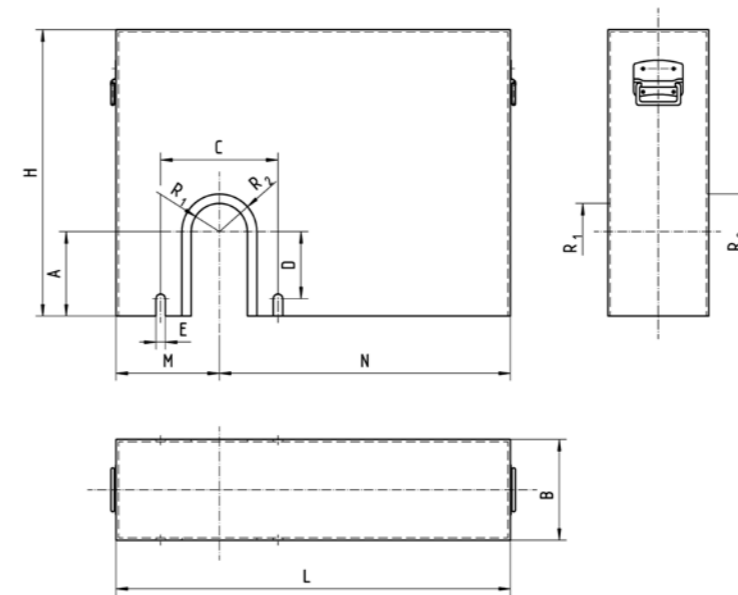

Plate thickness = 1,5 mm
 All enclosures are provided with handles
 Other dimensions upon request

All dimensions in mm
 Alterations reserved without notice

Brake type	A	B	C	D	E	H	L	M	N	R _{max}
EBN 200-22-5	150	180	200	118	10	530	710	195	515	90
EBN 200-30-5	150	180	200	118	10	530	710	195	515	90
EBN 200-50-6	150	180	200	118	10	580	750	195	555	90
EBN 250-22-5	180	180	250	143	10	530	820	220	600	110
EBN 250-30-5	180	180	250	143	10	610	820	220	600	110
EBN 250-50-6	180	180	250	143	10	610	860	220	640	110
EBN 250-80-6	180	180	250	143	10	610	860	220	640	110
EBN 315-30-5	220	180	315	179	12	700	940	280	660	140
EBN 315-50-6	220	180	315	179	12	700	1020	280	740	140
EBN 315-80-6	220	180	315	179	12	700	1020	280	740	140
EBN 400-50-6	260	180	400	205	12	710	1120	320	800	180
EBN 400-80-6	260	180	400	205	12	710	1120	320	800	180
EBN 400-125-6	260	180	400	205	12	830	1120	320	800	180
EBN 500-50-6	320	220	500	260	12	900	1310	400	910	230
EBN 500-80-6	320	220	500	260	12	900	1310	400	910	230
EBN 500-125-6	320	220	500	260	12	900	1310	400	910	230
EBN 630-80-6	400	270	630	325	14	1080	1380	470	910	290
EBN 630-125-6	400	270	630	325	14	1080	1380	470	910	290
EBN 630-200-6	400	270	630	325	14	1080	1380	470	910	290
EBN 710-80-6	450	300	710	370	14	1150	1540	530	1010	330
EBN 710-125-6	450	300	710	370	14	1150	1540	530	1010	330
EBN 710-200-6	450	300	710	370	14	1150	1540	530	1010	330

When ordering please advise: Brake type, Dimension "R₁ and R₂"

Band Brake Type BHB

Dimensions and technical data



Rev. 11-04

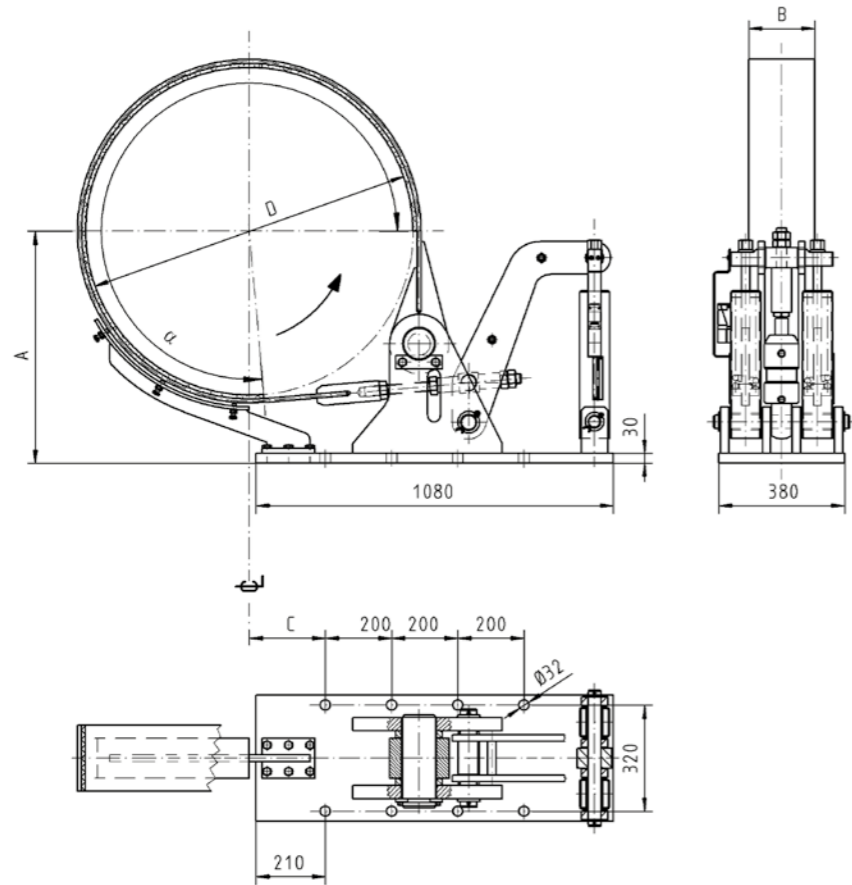

*) Average static friction factor of standard material combination

All dimensions in mm
Alterations reserved without notice

Other diameters and release by thruster upon request

Brake type	A	D	C	E	M _{Br} (kNm) μ=0,4*	Band width (B)
BHB 990-80/60	700	990	20	230	min. 60	
					<100	120
					<160	160
BHB 1110-80/60	760	1110	80	290	max. 203	200
					min. 70	
					<140	120
BHB 1240-80/60	825	1240	145	355	<180	160
					max. 230	200
					min. 60	
BHB 790-80/60 (Wrap angle 265° !)	600	790	-30	180	<160	120
					<200	160
					max. 253	200
					min. 60	120
					<100	160
					max. 130	200

Band Brake Type BHB

Hydraulic power unit for one or more brakes



Rev. 05-17

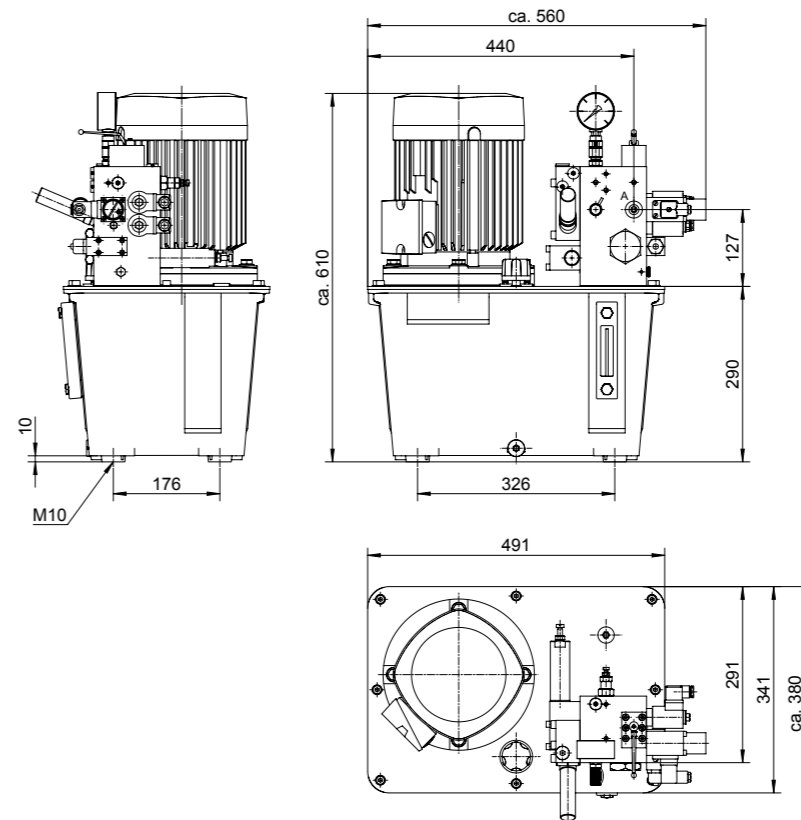

Example:	
Motor:	3 kW
Pump:	7,9 l/min at 50 Hz
Pressure:	180 bar
Tank:	30 l

The flow diagram shows the general arrangement of the hydraulic power unit, including hand pump for emergency manual release of the brakes.

The two solenoid valves are connected in parallel (redundancy). After the nominal pressure is reached, the idler valve switches into idle running. The motor is continuously energized. Pressure switch, temperature switch, space heater and other accessories are available as options.

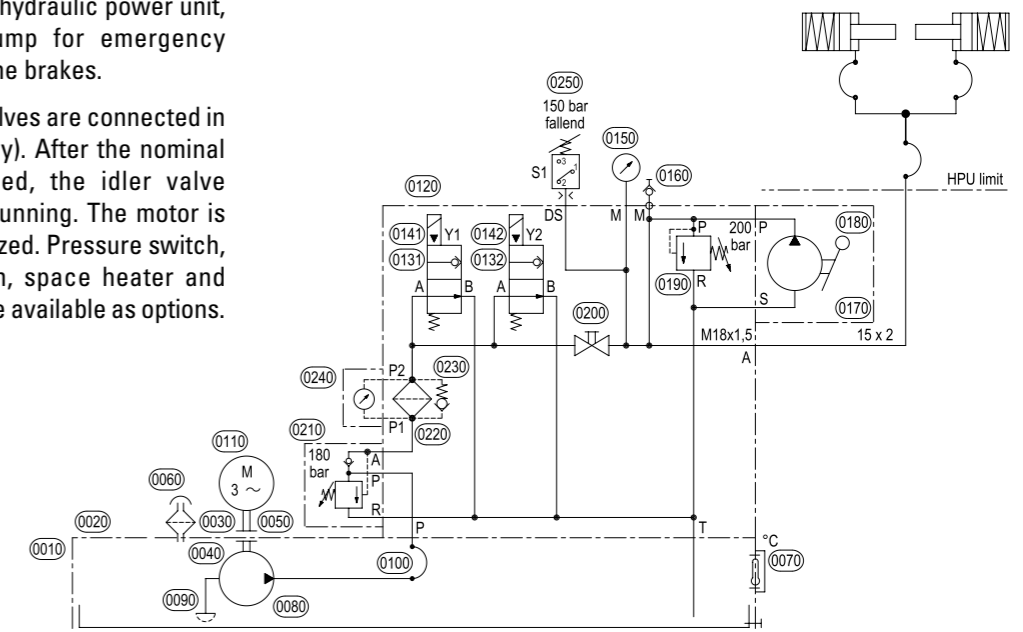

All dimensions in mm
Alterations reserved without notice

We supply a complete hydraulic and electric diagram according to the order specification with every order.

Notes



Flexible Coupling Type K

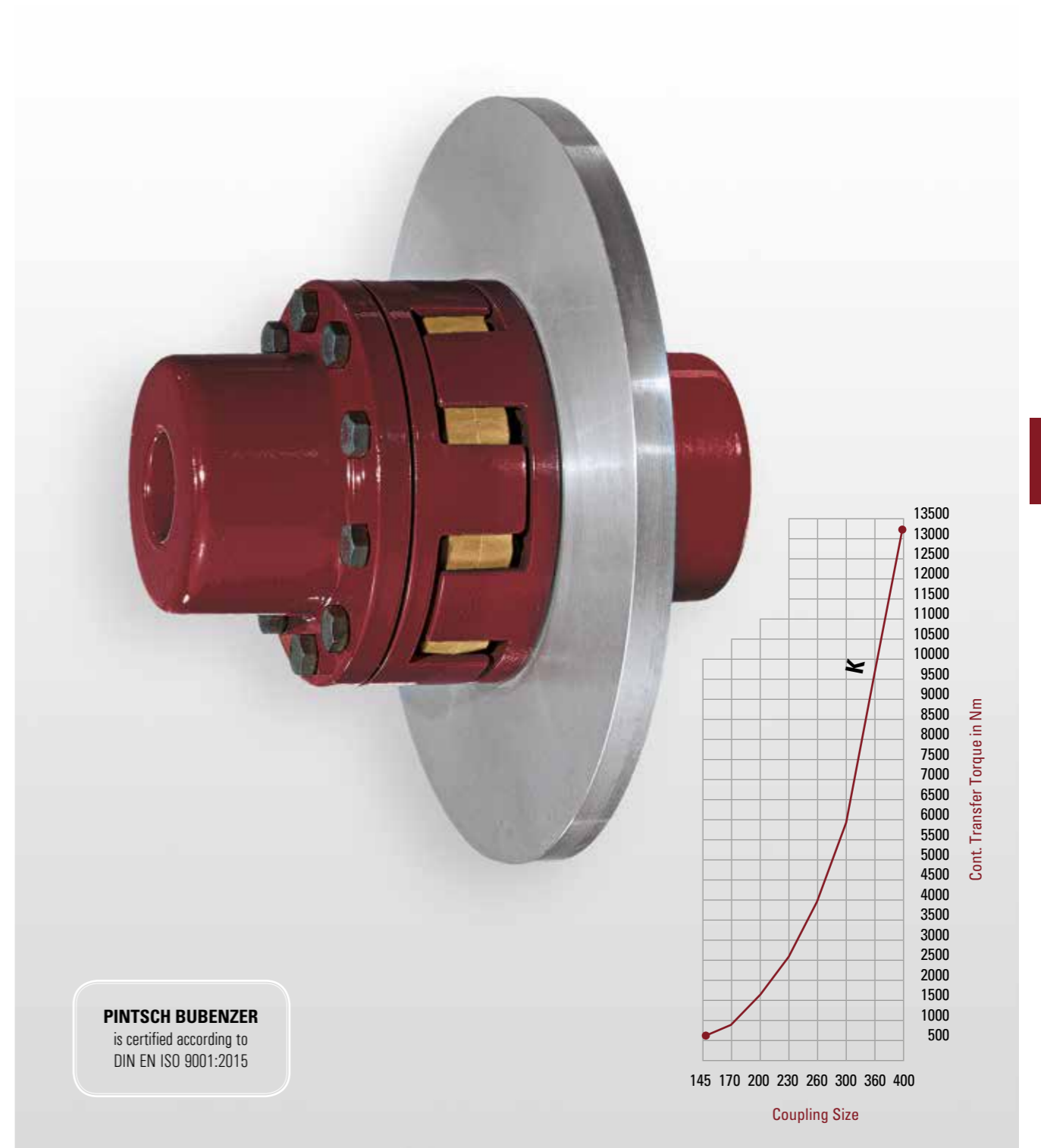

Easy Maintenance



High Performance



Robust Design



Torsionally Elastic



Tried and Trusted

Description Coupling Type K



Main Features

- Steel coupling, torsionally elastic and bullet-proof (fail safe)
- Torque transmission via elastic intermediate ring
- Replacement of the elastic intermediate ring or the brake disc without moving any equipment
- Arrangement of the brake drum on the gear side to allow the brake torque to be maintained when the motor is disengaged
- Vast selection of coupling sizes and brake disc diameters

Options

- Coupling hubs finish bored and keywayed acc. to DIN 6885
- Coupling hubs unbored
- Coupling hubs pilot bored
- Coupling dynamically balanced according to ISO 1940 Grade: G 2.5; G 6.3
- Coupling hubs in special lengths
- Coupling hubs in special material
- Test certificate DIN EN 10204-3.1

Ordering Example

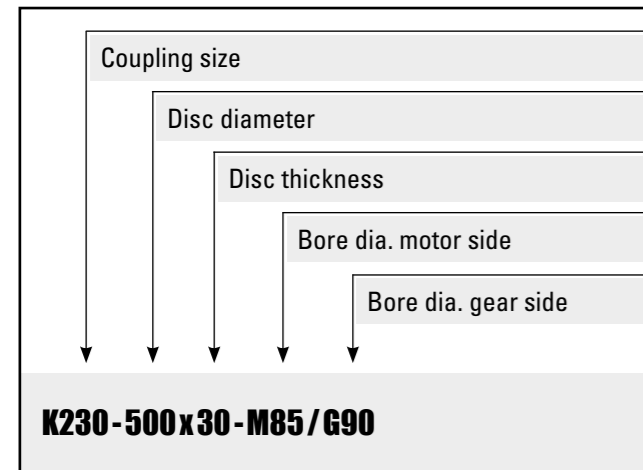

Applications

- These couplings are for use in application with high dynamic loads
- Damping of peak torques and vibrations as well as electrical insulation between motor and gearbox are further reasons for the use of this coupling type
- The standard material of the elastic intermediate ring Polyurethane (Vulkollan) is suitable for a temperature range of -35°C up to +80°C. For a short time -40°C up to +100°C

Flexible Coupling Type K

Dimensions and technical data



Rev. 10-16

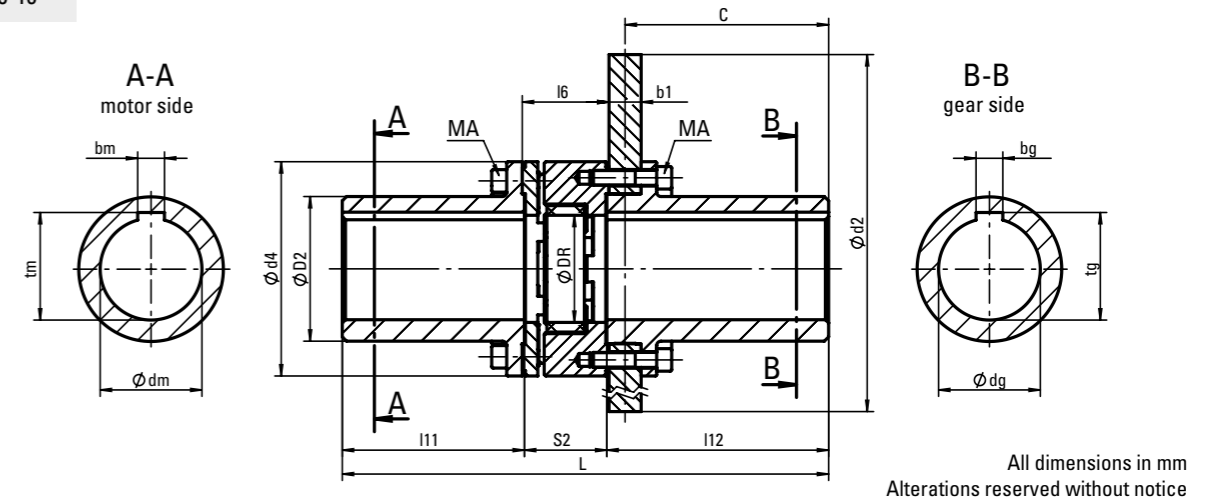

Coupling K (size = d ₄)		145	170	200	230	260	300	360	400
M _{Br} max.	Nm	1800	2850	4950	7740	11940	17550	29100	40050
T _{KN} (VK60D)	Nm	600	950	1650	2580	3980	5850	9700	13350
n _{max.} at max. disc-Ø	min ⁻¹	3800	3400	3000	2700	2400	2200	1750	1750
d _m max. + d _g max.	mm	65	75	95	110	125	140	160	160
D ₂	mm	92	110	135	160	180	200	225	225
D _R	mm	67	90	100	115	150	162	215	250
L	mm	344,5	374,5	454	458,5	518,5	535,5	627,5	627,5
l ₁₁	mm	110	140	170	170	210	210	250	250
l ₁₂	mm	166,5	166,5	207	207,5	212,5	212,5	252,5	252,5
l ₆	mm	71 +2,5	71 +3	81 +3	86 +3,5	101 +4	118 +4	130 +4	130 +4
S ₂	mm	68	68	77	81	96	113	125	125
C (b ₁ = 30 mm / 40 mm)	mm	150 / -	150 / -	190 / -	190 / -	195 / -	195 / -	235 / 230	235 / 230
M _A (DIN 912-8.8; μ=0,12)	Nm	84	84	132	132	206	410	710	710
Brake disc diameter d ₂ x b ₁ (mm)	355 x 30	kg 41	Weight						
		kgm ² 0,3973	Moment of inertia						
	400 x 30	47	54	76					
		0,6219	0,656	0,801					
	450 x 30	55	62	84					
		0,9781	1,016	1,158					
	500 x 30		71	93	116	139			
			1,513	1,655	1,782	2,123			
	560 x 30			105	128	150			
				2,484	2,611	2,960			
	630 x 30				143	168	189		
					3,98	4,330	4,704		
710 x 30					185	225			
					6,563	6,92			
800 x 30						250	311		
						10,52	11,49		
900 x 30								342	354
								17,21	17,69
1000 x 30								376	389
								25,16	25,65

Weights and moments of inertia are not binding, referring to the max. finish bore for the sizes 145 to 300 respectively for a finish bore of 120 mm for the sizes 360 and 400.



Please Note

We supply a detailed operating manual with every order. Couplings are rotating parts and as such a cover must be fitted for the prevention of accidents.



PINTSCH BUBENZER Service

This includes the verification of the coupling selection, if required. A detailed questionnaire is provided for this purpose. Installation and commissioning on-site by PINTSCH BUBENZER service engineers is possible. Drawings as DWG/DXF files for your engineering department are available upon request.

Flexible Coupling Type K

Design



Rev. 10-16

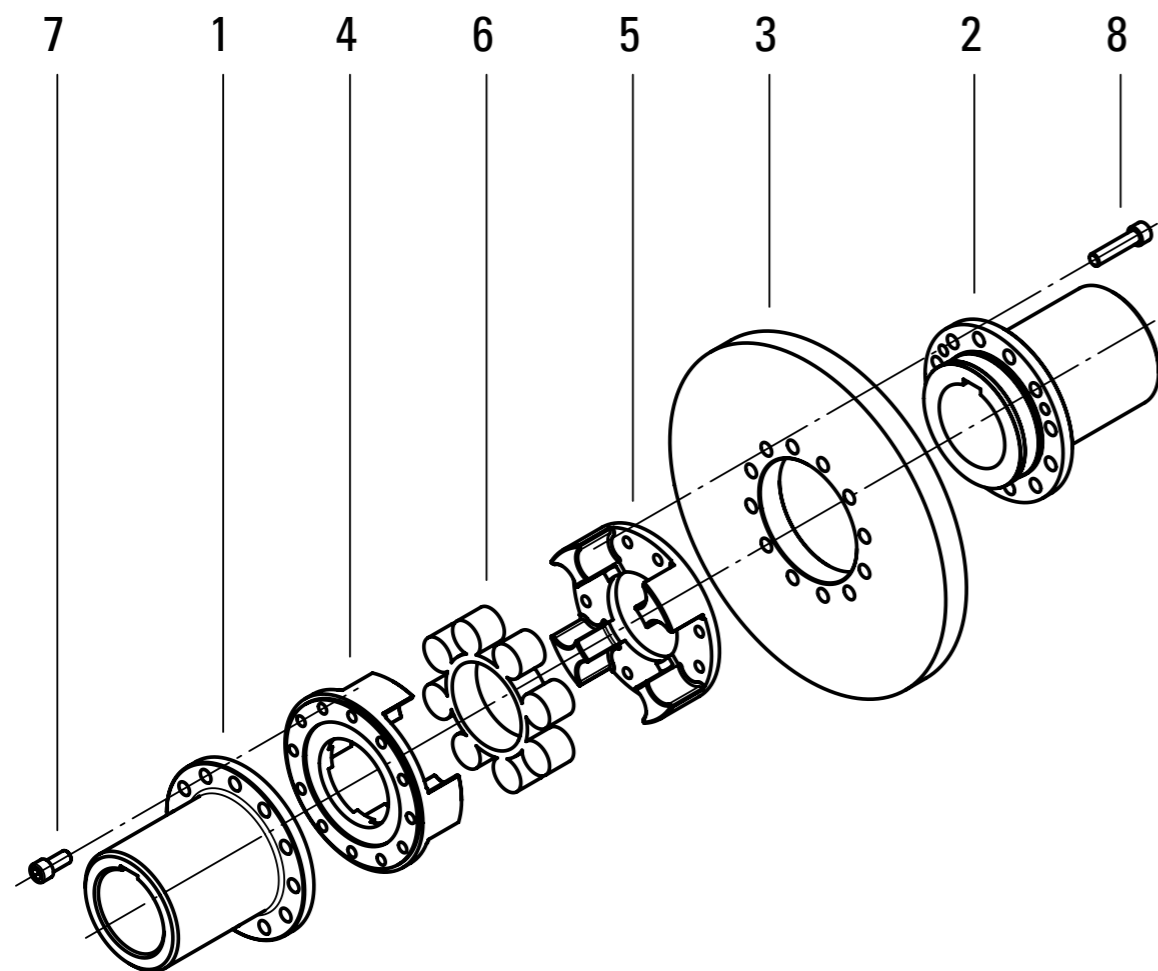

1	Hub, motor side
2	Hub, gear side
3	Brake disc
4	Claw ring, removable
5	Claw ring, removable
6	Elastic intermediate ring
7	Hexagon socket head screw
8	Hexagon socket head screw

Flexible Coupling Type KHD



PINTSCH BUBENZER
is certified according to
DIN EN ISO 9001:2015



Easy Maintenance



High Performance



Robust Design



Torsionally Elastic



Tried and Trusted

E

Description Coupling Type KHD



Main Features

- Steel coupling, torsionally elastic and bullet-proof (fail safe)
- Torque transmission via elastic buffers
- Buffer elements can be radially replaced by pushing back the retaining ring without moving any equipment
- Arrangement of the brake drum on the gear side to allow the brake torque to be maintained when the motor is disengaged
- Elastic buffers provide superb electrical insulating characteristics (e.g. prevents leaking currents)

Options

- Coupling hubs finish bored and keywayed acc. to DIN 6885
- Coupling hubs unbored
- Coupling hubs pilot bored
- Coupling dynamically balanced according to ISO 1940 Grade: G 2.5; G 6.3
- Coupling hubs in special lengths
- Coupling hubs in special material
- Test certificate DIN EN 10204-3.1

Applications

- These couplings are for use in application with high dynamic loads
- Damping of peak torques and vibrations as well as electrical insulation between motor and gearbox are further reasons for the use of this coupling type
- The standard material of the elastic intermediate ring Polyurethane (Vulkollan) is suitable for a temperature range of -35°C up to +80°C. For a short time -40°C up to +100°C

Ordering Example

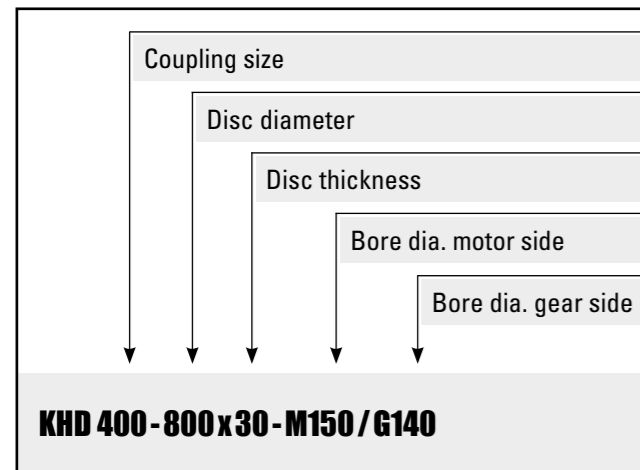

Flexible Coupling Type KHD

Dimensions and technical data



Rev. 10-16

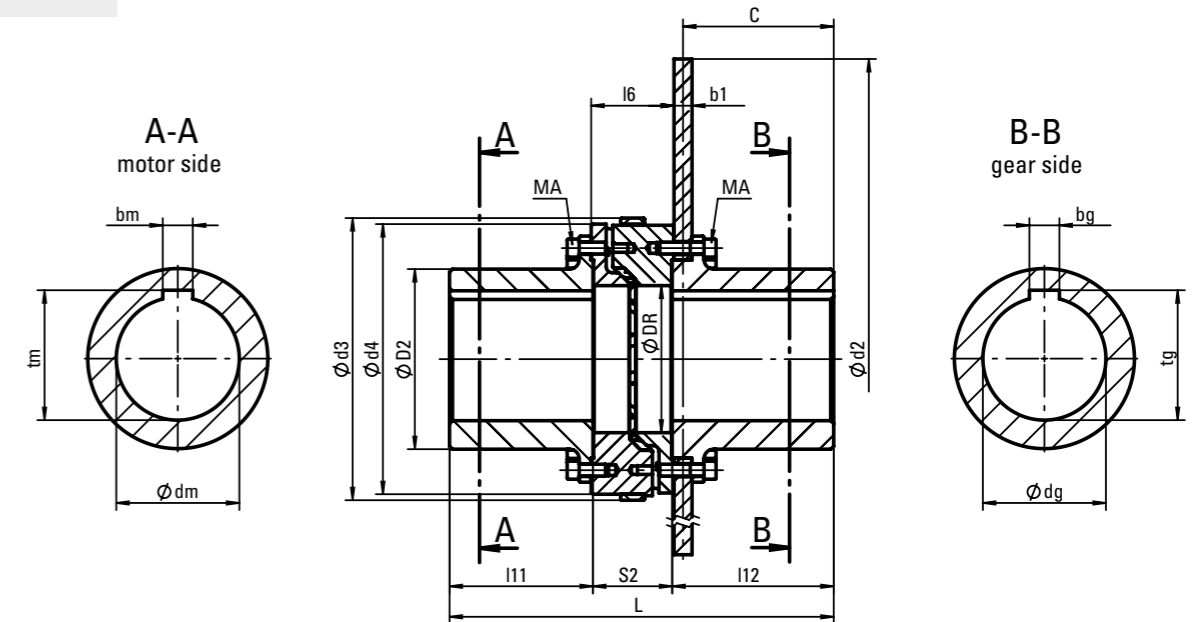

Coupling KHD (size = d ₄)		400	450
M _{BR} max.	Nm	48000	62000
T _{KN} (VKW)	Nm	19900	25200
d _m max. / d _g max.	mm	190	205
D ₂	mm	280	300
D _R	mm	204	245
d ₃	mm	420	470
L (b ₁ = 30 mm / 40 mm)	mm	640 / 650	640 / 650
l ₁₁	mm	239	239
l ₁₂ (b ₁ = 30 mm / 40 mm)	mm	269 / 279	269 / 279
l ₆	mm	138	138
S ₂	mm	132	132
C (b ₁ = 30 mm / 40 mm)	mm	251 / 256	251 / 256
M _A (DIN 912-8.8; μ=0,12)	Nm	440	440
Brake disc diameter d ₂ x b ₁ (mm)	800 x 30	n _{max.} 2200 min ⁻¹	320 13,428
	900 x 30	n _{max.} 1950 min ⁻¹	351 19,091
	1000 x 30	n _{max.} 1750 min ⁻¹	386 26,991
	1250 x 30	n _{max.} 1400 min ⁻¹	520 61,705
	800 x 40	n _{max.} 2200 min ⁻¹	355 16,526
	900 x 40	n _{max.} 1950 min ⁻¹	397 24,076
	1000 x 40	n _{max.} 1750 min ⁻¹	444 34,610
	1250 x 40	n _{max.} 1400 min ⁻¹	614 80,381

Weight kg
Moment of inertia kgm²

Weights and moments of inertia of the coupling with steel brake disc are not binding, referring to the max. finish bore!

All dimensions in mm
Alterations reserved without notice



Please Note

We supply a detailed operating manual with every order. Couplings are rotating parts and as such a cover must be fitted for the prevention of accidents.



PINTSCH BUBENZER Service

This includes the verification of the coupling selection, if required. A detailed questionnaire is provided for this purpose. Installation and commissioning on-site by PINTSCH BUBENZER service engineers is possible. Drawings as DWG/DXF files for your engineering department are available upon request.

Flexible Coupling Type KHD

Design



Rev. 02-17

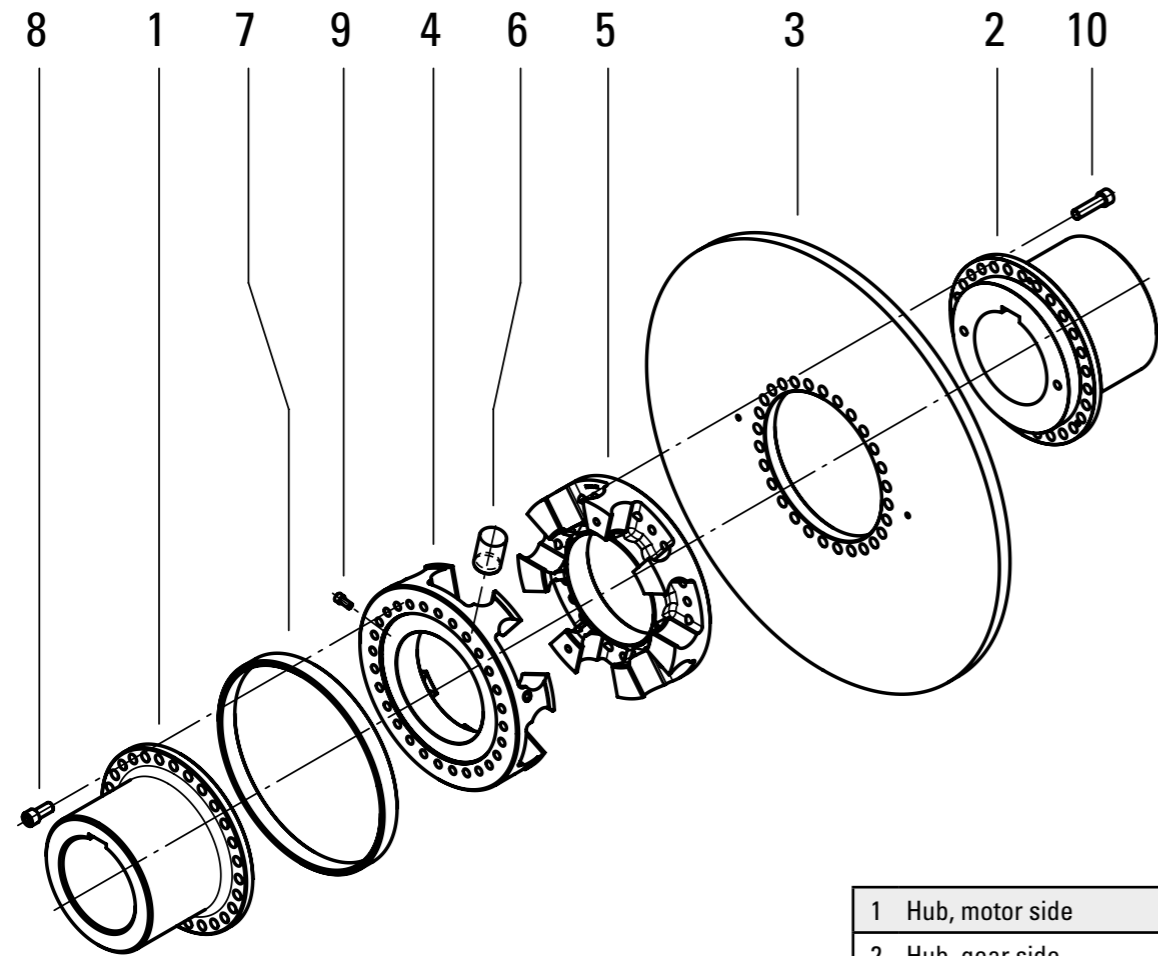

1	Hub, motor side
2	Hub, gear side
3	Brake disc
4	Claw ring, removable
5	Claw ring, removable
6	Elastic buffer
7	Retaining ring
8	Hexagon socket head screw
9	Hexagon socket head screw
10	Hexagon socket head screw

Hub with Brake Disc Type N + NX



PINTSCH BUBENZER
is certified according to
DIN EN ISO 9001:2015

Hub Size	Maximum Brake Torque in Nm
145	~1000
170	~2000
200	~4000
230	~8000
260	~14000
300	~18000
360	~32000
400	~38000



Easy Maintenance



Robust Design



Safe



Tried and Trusted

E

Description Hub Type N + NX



Main Features

- Hub/disc combination for easy exchange of brake disc (type N)
- High accident prevention by fastening ring, no rotating nuts (type N)
- Exchange of brake disc without removing the hub (type N)
- Simple, one-piece design with 20 mm brake disc thickness for SB8.11 + SB17 series brakes (type NX)

Options

- Hubs finish bored and keywayed acc. to DIN 6885
- Hubs unbored
- Hubs pilot bored
- Hubs with brake disc, dynamically balanced according to ISO 1940 Grade: G 2.5; G 6.3
- Hubs in special dimensions
- Hubs in special material
- Test certificate DIN EN 10204-3.1

Ordering Example

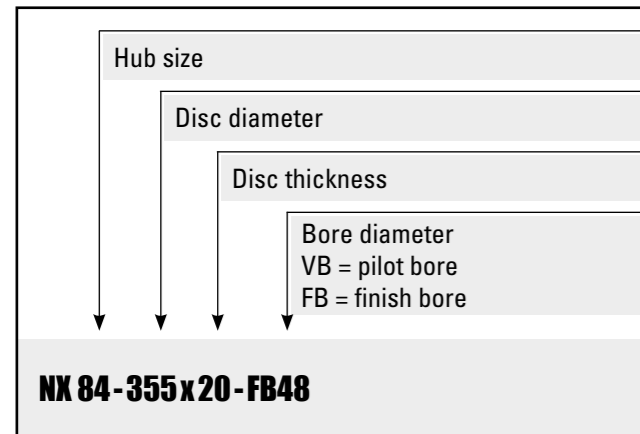

Ordering Example

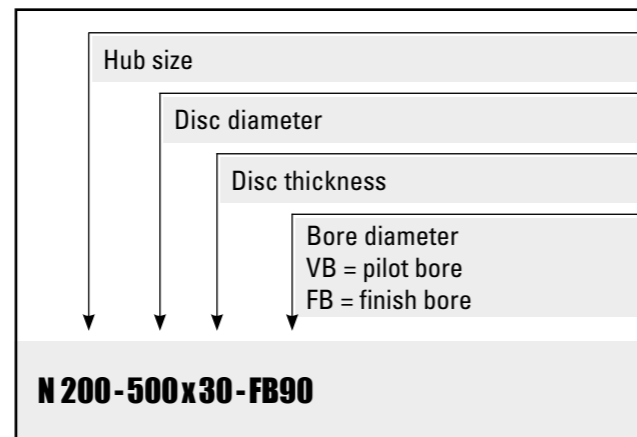

Applications

All drives, where the brake is not located between motor and gearbox, like brake installation on the second gear box shaft or at the motor end shaft



Please Note

We supply a detailed operating manual with every order. Hubs with brake discs are rotating parts and as such a cover must be fitted for the prevention of accidents.



PINTSCH BUBENZER Service

This includes the verification of the hub selection, if required. A detailed questionnaire is provided for this purpose. Installation and commissioning on-site by PINTSCH BUBENZER service engineers is possible. Drawings as DWG/DXF files for your engineering department are available upon request.

Hub with Brake Disc Type N

Dimensions and technical data



Rev. 10-16

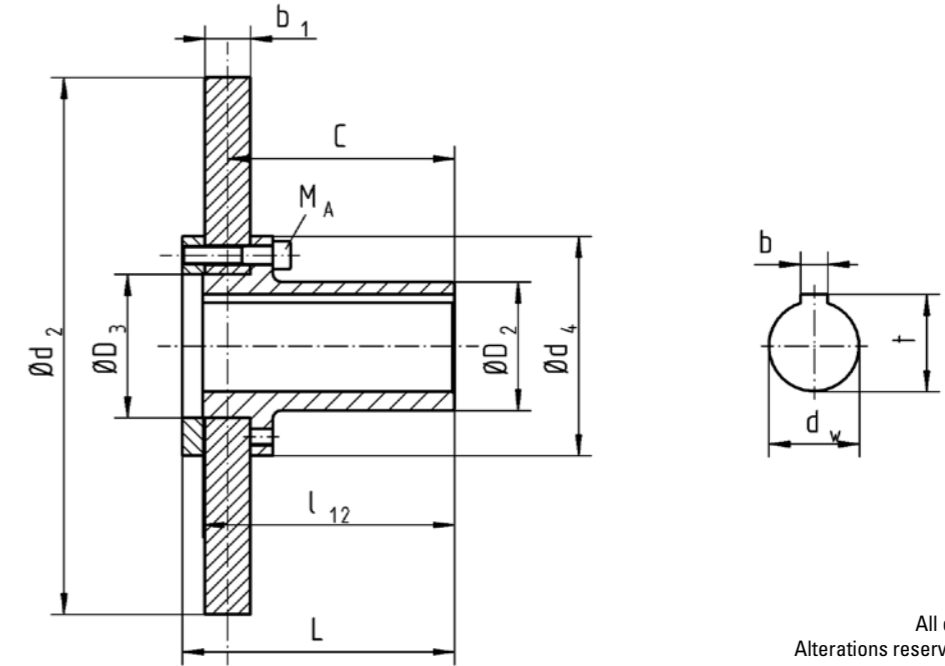

All dimensions in mm
Alterations reserved without notice

Hub N (size = d ₄)		145	170	200	230	260	300	360	400	
M _{Br} max.	Nm	1800	2850	4950	7740	11940	17550	29100	40050	
n _{max} at max. disc Ø	min ⁻¹	3800	3400	3000	2700	2400	2200	1750	1750	
dw max.	mm	60	75	95	110	125	140	160	160	
D ₂	mm	85	110	135	160	180	200	225	225	
D ₃	mm	95	120	140	170	200	220	260	300	
L	mm	180	180	220	220	230	230	275	275	
l ₁₂	mm	166,5	166,5	207	207,5	212,5	212,5	252,5	252,5	
C	mm	150	150	190	190	195	195	235*	235*	
M _A (DIN 912-8.8; μ=0,12)	Nm	84	84	132	132	206	410	710	710	
Brake disc diameter d ₂ x b ₁ (mm)	355 x 30	kg kgm ²	28 0,378			Weight Moment of inertia of the hub with brake disc				kg kgm ²
	400 x 30		35	37	44					
			0,603	0,612	0,653					
	450 x 30		42	45	52					
			0,959	0,973	1,011					
	500 x 30			54	60	67	77			
				1,469	1,506	1,571	1,682			
	560 x 30				72	79	89			
					2,335	2,399	2,51			
	630 x 30					95	105	109		
					3,768	3,879	4,081			
710 x 30						124	128			
						6,112	6,213			
800 x 30	Weights and moments of inertia are not binding, referring to the max. finish bore for the sizes 145 to 300 respectively for a finish bore of 120 mm for the sizes 360 and 400.						153	189		
900 x 30							9,808	10,456		
								221	232	
1000 x 30								16,123	16,473	
								257	267	
	* Dimension C = 230 mm at brake disc thickness 40 mm							24,075	24,424	

Hub with Brake Disc Type NX

Dimensions and technical data



Rev. 12-06

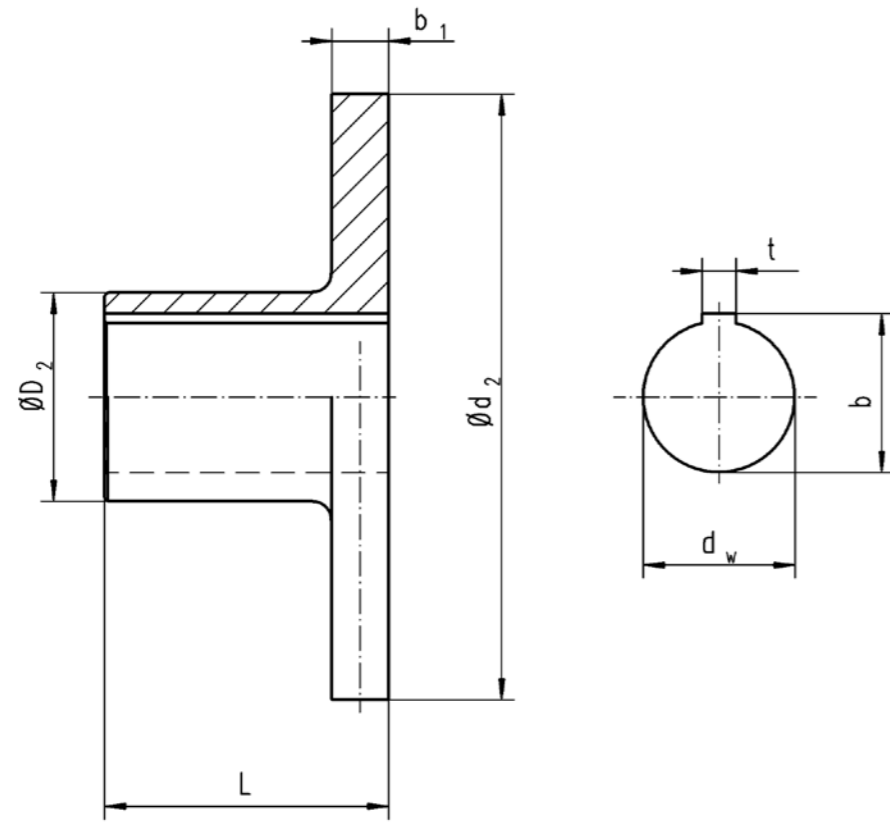

* Higher speeds possible by using sintered linings

All dimensions in mm
Alterations reserved without notice

Hub NX (size = D ₂)		58	64	74	84	92	100	114		
L mm		80	110	110	110	140	140	140		
dw max. mm		38	42	48	55	60	65	70		
Brake disc diameter d ₂ x b ₁ (mm)	200 x 20	3500	344	5,6	6,2	Weight of the hub with brake disc				kg
				0,025	0,026	Moment of inertia				kgm ²
	225 x 20	3300	399	7,0	7,5	8,1	8,6	9,3	10,9	
				0,040	0,040	0,041	0,042	0,045	0,047	
	250 x 20	3000	474	8,5	9,0	9,6	10,1	10,8	12,4	14,0
				0,060	0,061	0,062	0,063	0,066	0,067	0,072
	280 x 20	2675	567	10,5	11,0	11,6	12,2	13,0	14,5	16,2
				0,095	0,096	0,096	0,097	0,100	0,102	0,107
	315 x 20	2380	653	13,2	13,7	14,3	14,9	15,5	17,1	18,7
				0,153	0,153	0,153	0,154	0,157	0,159	0,164
355x 20	2100	752		17,0	17,6	18,2	18,9	20,5	22,2	
				0,246	0,246	0,274	0,250	0,252	0,257	
400 x 20	1875	863		21,0	21,6	22,2	22,8	24,4	26,0	
				0,396	0,396	0,397	0,400	0,402	0,407	
450 x 20	1650	986		27,0	27,7	28,4	30,0	31,7		
				0,634	0,635	0,637	0,639	0,645		
500 x 20	1500	1100		33,0	33,7	34,4	36,0	37,7		
				0,956	0,966	0,969	0,970	0,976		

Brake Drums acc. to DIN 15431

Dimensions and technical data



Rev. 11-16

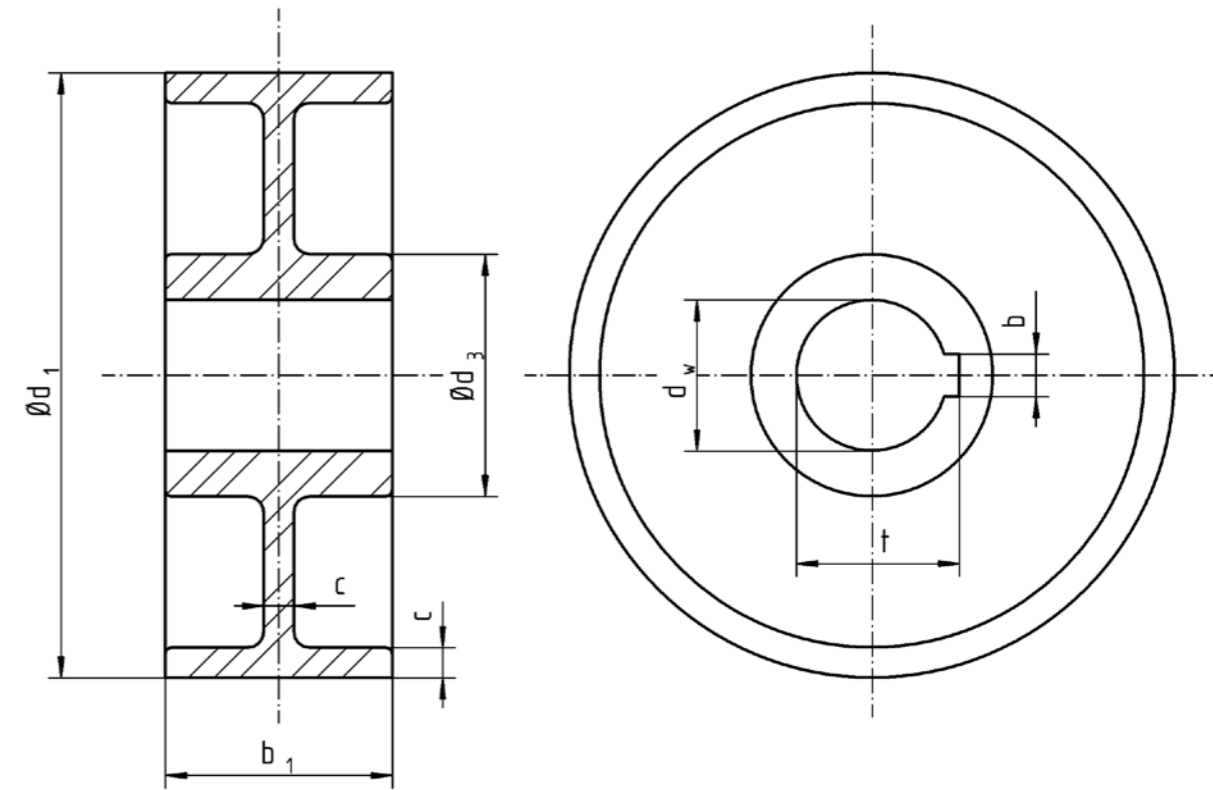

All dimensions in mm
Alterations reserved without notice

Weights and moments of inertia are not binding, referring to the max. finish bore!

Material options:	S355J2G3
	Special material
When ordering please indicate:	Brake Drum Ø d ₁
	Bore Ø d _w

d ₁	b ₁	c	d _w		d ₃	Moment of inertia J kgm ²	Weight kg
			Pilot bored	max. finish bored			
200	75	10	20	50	80	0,042	7,0
250	95	12	25	60	95	0,124	13,0
315	118	15	30	80	115	0,383	24,3
400	150	17	35	90	130	1,151	44,7
500	190	20	50	100	150	3,356	83,1
630	236	25	50	110	170	10,396	160,1
710	265	30	70	120	200	19,869	246,0



The brake drums can be balanced on request if ordered finish bored and keywayed. If requested, brake drums can be made according to customer specifications.

Notes



Lined area for notes.

LiTec® Brake Disc

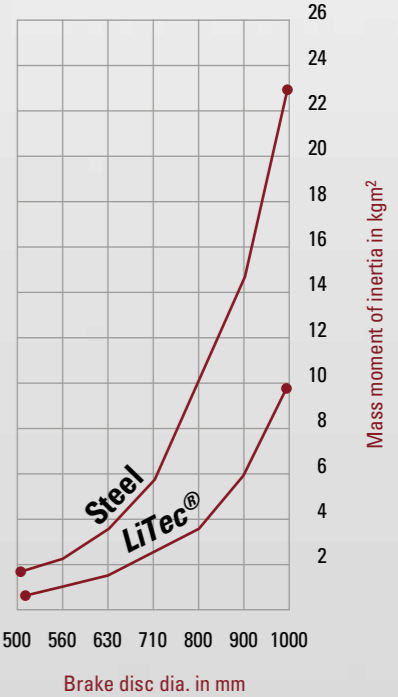

Brake disc dia. in mm	Steel (kgm²)	LiTec® (kgm²)
500	~1.5	~0.8
560	~2.5	~1.2
630	~4.5	~1.8
710	~8.5	~2.8
800	~15.5	~4.5
900	~24.5	~7.5
1000	~25.5	~10.5

PINTSCH BUBENZER
is certified according to
DIN EN ISO 9001:2015

E



Easily Interchangeable



High Friction Coefficient



Low inertia



Low Wear

Description *LiTec*[®] Brake Disc

Main Features

New brake disc material <i>LiTec</i> [®] is based on alloyed aluminum
60% lower moment of inertia
10% higher friction coefficient in combination with B2 sintered linings
Improved heat dissipation
Improved hoist acceleration
Improved crane performance
Wear resistant
Corrosion resistant
Field tested

Applications

Retrofittable on all PINTSCH BUBENZER hubs and couplings
<i>LiTec</i> [®] is one of the core components for the PB SOS system. (also see SOS brochure)

Gear Coupling Type KBT

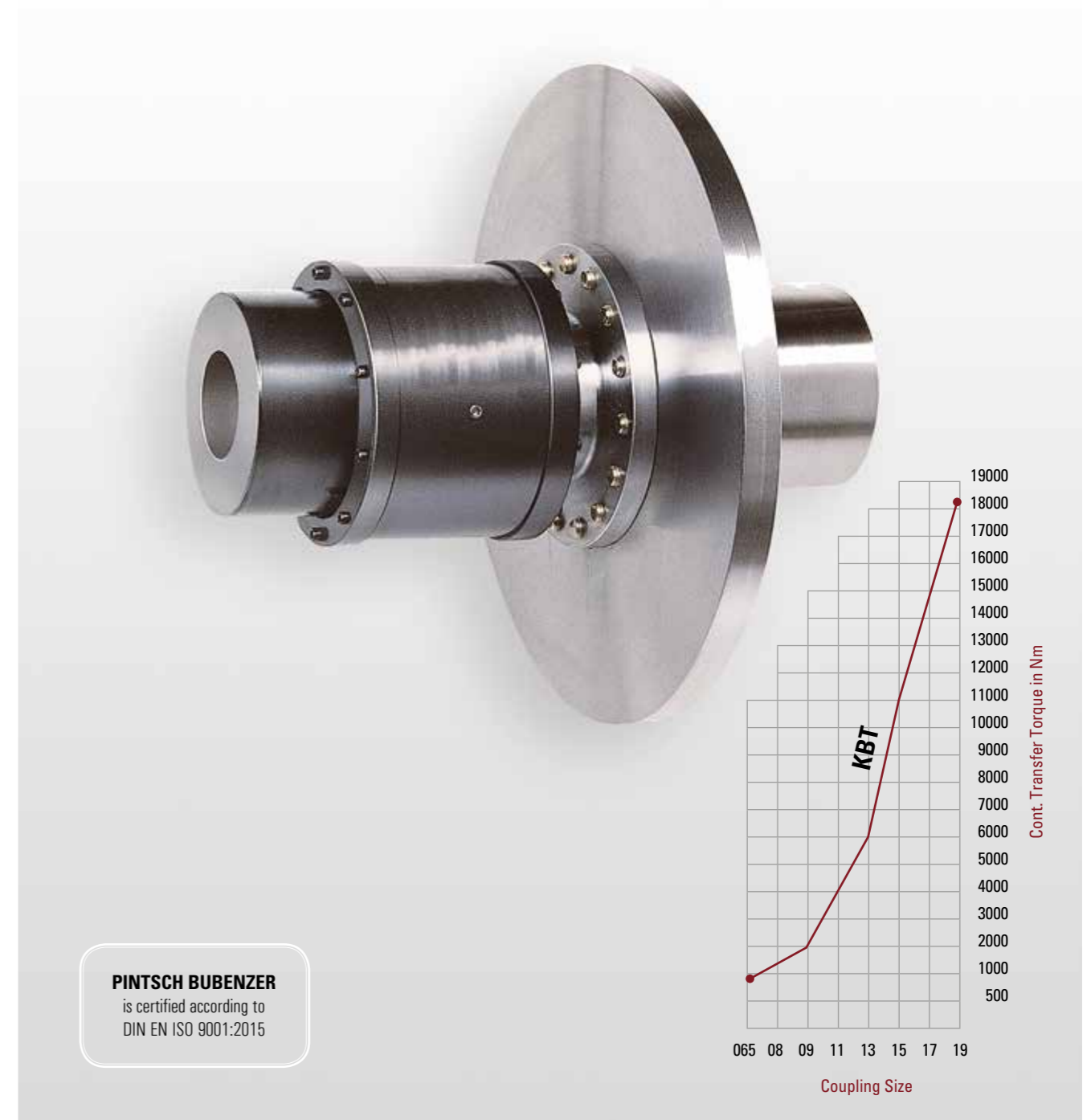

E



Please Note

We supply a detailed operating manual with every order. Couplings are rotating parts and as such a cover must be fitted for the prevention of accidents.

For more details please see our separate couplings catalogue.



PINTSCH BUBENZER Service

This includes the verification of the coupling selection, if required. A detailed questionnaire is provided for this purpose. Installation and commissioning on-site by PINTSCH BUBENZER service engineers is possible. Drawings as DWG/DXF files for your engineering department are available upon request.



Easy Maintenance



High Performance



Robust Design



Torsionally Rigid



Tried and Trusted

Description Coupling Type KBT



Main Features

- Steel coupling with special tooth pattern
- Torque transmission via internal geared sleeve and external geared hubs
- Replacement of the brake disc or the seals without moving any equipment
- High temperature resistance
- Low wear
- Arrangement of the brake drum on the gear side to allow the brake torque to be maintained when the motor is disengaged
- Vast selection of coupling sizes and brake disc diameters

Options

- Coupling hubs finish bored and keywayed acc. to DIN 6885
- Coupling hubs unbored
- Coupling hubs pilot bored
- Coupling dynamically balanced according to ISO 1940 Grade: G 2.5; G 6.3
- Hubs in special dimensions
- Hubs in special material
- Test certificate DIN EN 10204-3.1

Applications

These couplings are for use in machinery where a torsionally rigid torque is required, especially on frequently varying loads and speeds

Ordering Example

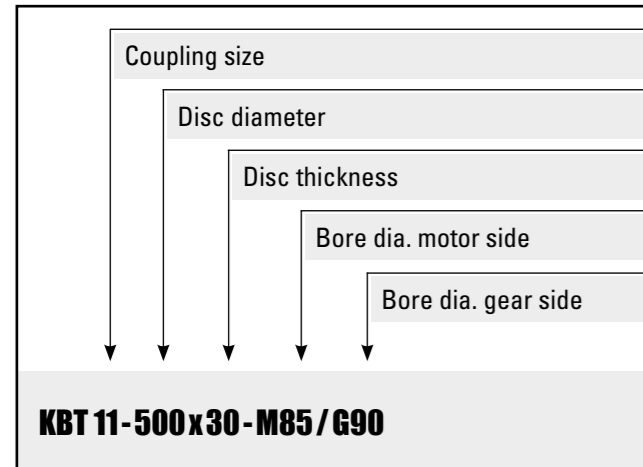

Gear Coupling Type KBT

Dimensions and technical data



Rev. 09-02

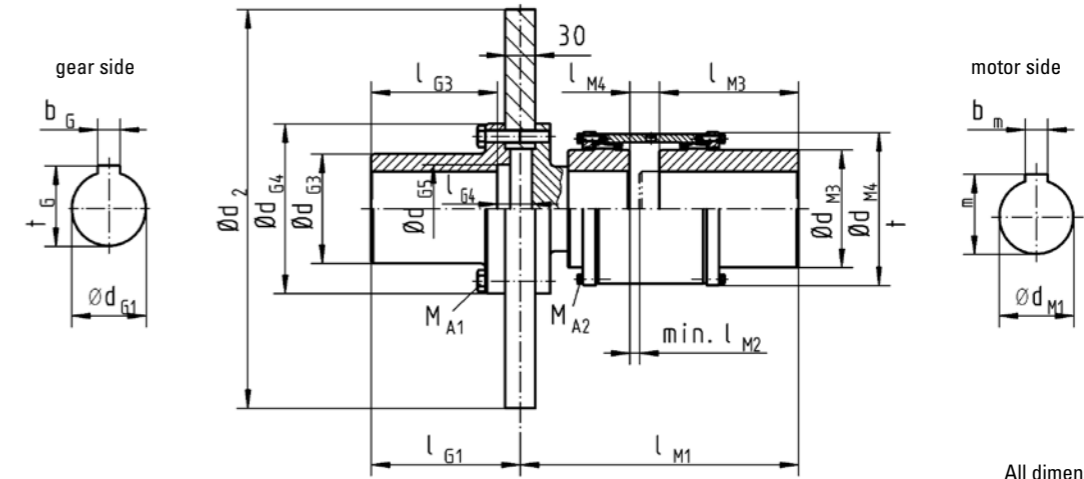

All dimensions in mm
Alterations reserved without notice

Coupling KBT		065	08	09	11	13	15	17	19
M _{Br} max.	Nm	2000	4000	5000	9250	15250	27500	36500	46000
T _{KN}	Nm	800	1600	2000	3700	6100	11000	14600	18400
n _{max} at max. disc Ø	min ⁻¹	3800	3400	2750	2400	2150	2150	1900	1900
d _{G1} max.	mm	55	75	90	110	120	140	160	195
d _{G3}	mm	85	110	130	160	180	200	225	265
d _{G4}	mm	145	170	200	230	260	300	360	400
d _{G5}	mm	68	88	105	130	140	162	184	225
d _{M1} max.	mm	70	85	95	110	130	155	175	195
d _{M3}	mm	100	118	130	151	178	213	235	263
d _{M4}	mm	140	154	161	186	216	254	282	317
l _{G1}	mm	150	150	190	190	195	195	235	235
l _{G3}	mm	127	127	167	167	172	172	212	212
l _{G4}	mm	35	35	35	35	35	35	35	35
l _{M1}	mm	215	280	310	325	350	385	425	470
l _{M2}	mm	7	10	10	10	10	10	10	10
l _{M3}	mm	110	140	146	165	170	190	200	220
l _{M4}	mm	12	30	17	19	23	24	29	32
Brake disc diameter d ₂ x b ₁ (mm)	355 x 30	43			Weight of the coupling with brake disc				kg
		0,415			Moment of inertia				kgm ²
	400 x 30	49	62	79					
		0,639	0,73	0,752					
	450 x 30	57	70	87					
		0,996	1,09	1,108					
	500 x 30		79	96	119				
			1,585	1,605	1,783				
	560 x 30			108	131	161			
				2,434	2,611	2,915			
630 x 30			123	146	176	229			
			3,802	3,98	4,283	4,955			
710 x 30				166	196	248	310	393	
				6,213	6,516	7,118	8,351	10,23	
800 x 30					221	274	335	418	
					10,11	10,78	11,94	13,83	
900 x 30	Weights and moments of inertia are not binding, referring to the max. finish bore.							367	450
								17,64	19,53



Please Note

We supply a detailed operating manual with every order. Couplings are rotating parts and as such a cover must be fitted for the prevention of accidents.



PINTSCH BUBENZER Service

This includes the verification of the coupling selection, if required. A detailed questionnaire is provided for this purpose. Installation and commissioning on-site by PINTSCH BUBENZER service engineers is possible. Drawings as DWG/DXF files for your engineering department are available upon request.

Gear Coupling Type KBT

Design



Rev. 01-17

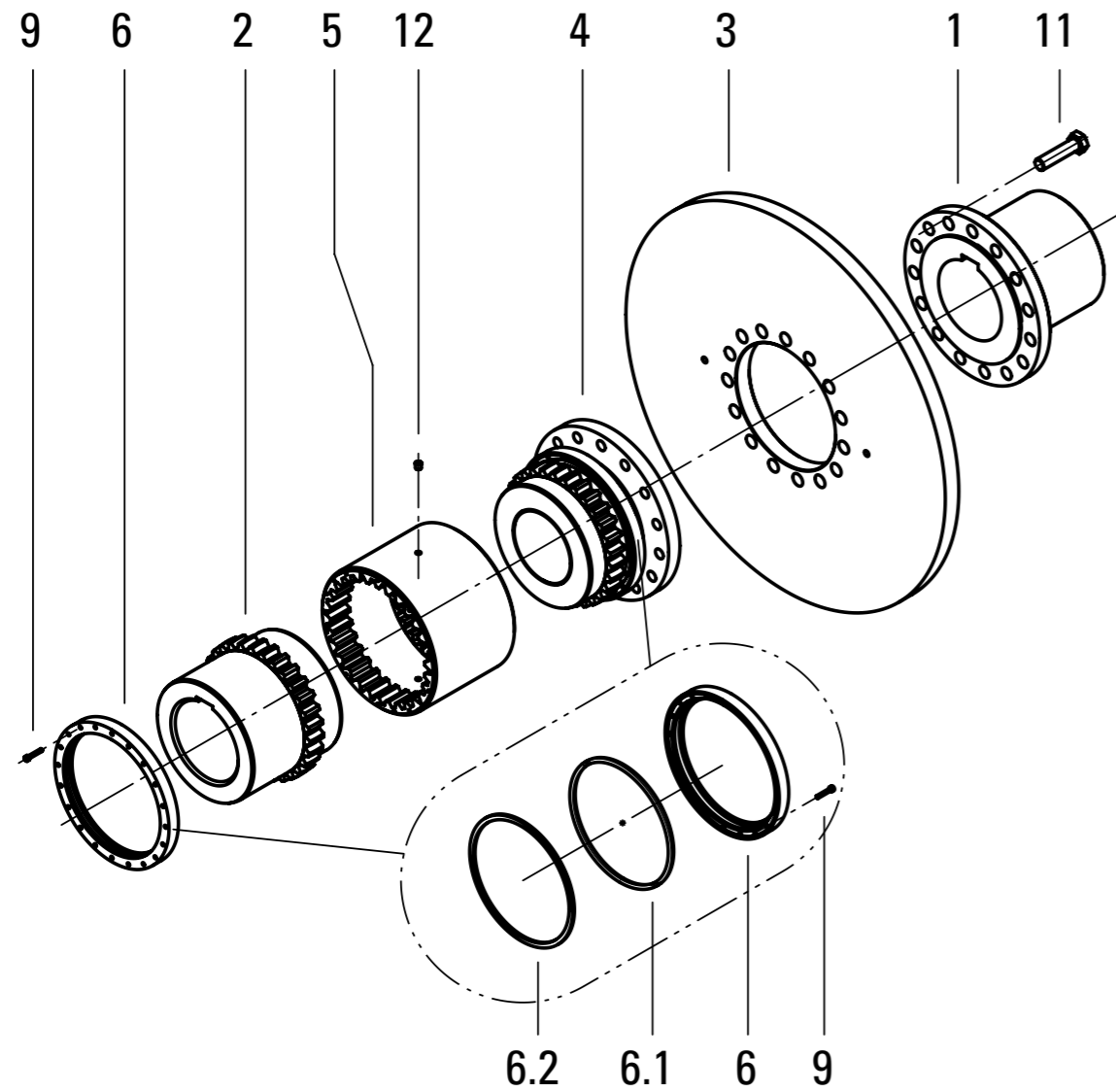

1	Hub, gear side
2	Hub, motor side
3	Brake disc
4	Flange with geared hub
5	Internal geared sleeve
6	End-cap with O-ring (6.1) and seal (6.2)
9	Hexagon socket head screw
11	Hexagon bolt
12	Screw plug

Monitoring System VSR2-SB



PINTSCH BUBENZER
is certified according to
DIN EN ISO 9001:2015

Visual indication of			
thruster stroke < 5 mm > 15 mm < 55 mm	maximum brake pad temperature	air gap difference between disc and pad surface by measuring the temperature difference between pads caused by unilateral pad rubbing	pad thickness < 5 mm

F

Description VSR2-SB



In response to requirements to simplify the maintenance of industrial brakes and at the same time to increase their operational safety, PINTSCH BUBENZER offers a retrofittable, compact electronic status indication system to be integrated into the brake as an additional device

Main Features

- Industrial display with 4 rows of 20 characters for indication of measurement data and error messages
- High ambient temperature range -20°C ... +70°C
- Protection class IP66
- Internal keypad for parameter change
- Up to 5 m cable length from sensor to electronic box. (Option)
- Brake operation cycle counter (up to 100 Mio. Cycles)
- Supply voltage selection switch 115/230 V AC
- One common error relay contact
- Option: Stainless steel electronic box IP66 for outdoor use

Parts for VSR2-SB

- Supply voltage:** The electronic unit can be connected directly to 110-240 VAC supply voltage. The internal voltage selector switch must be set by the user to the corresponding position 115 or 230 V
- Temperature sensor:** A pair of Pt100 sensors (B) measures the temperature of the each brake pad. If the temperature is too high or if the temperature is unequal from left to right side the unit generates a signal that is displayed in the panel.
- Pad wear sensor:** If the minimum brake pad thickness is reached, the sensors (A) send a signal to the electronic box
- Display:** All measured analogue and digital signals and error messages are shown on the display in English language. Other languages are available on request. The display is readable under direct sunshine and has a LED backlight for use in a dark environment, such as steel mills.
- Keypad:** With the internal key pad, the user can adjust parameters such as changing the temperature display from Celsius (°C) to Fahrenheit (°F) or setting of the Profibus address
- Reset button:** The LED pushbutton on top of the electronic box indicates a wrong brake adjustment by a flashing red light. After the problem on the brake is solved, the status of the VSR2-SB / CMB2-SB can be reset to normal operation by pushing the button.
- Proximity switch release control:** This switch and the optional manual release switch are independent from the VSR2-SB/ CMB2-SB and have to be connected to the control plc
- Stroke sensor:** A digital stroke sensor detects an Eldro reserve stroke <5mm or larger than 15 mm
- Relay contact:** A dry contact (max 250 V 2 A) is connected to terminals 21/22. It is closed in normal status of the VSR2-SB and open, if the system is in error mode, or switched off

Monitoring System VSR2-SB

Dimensions and technical data



Rev. 05-16

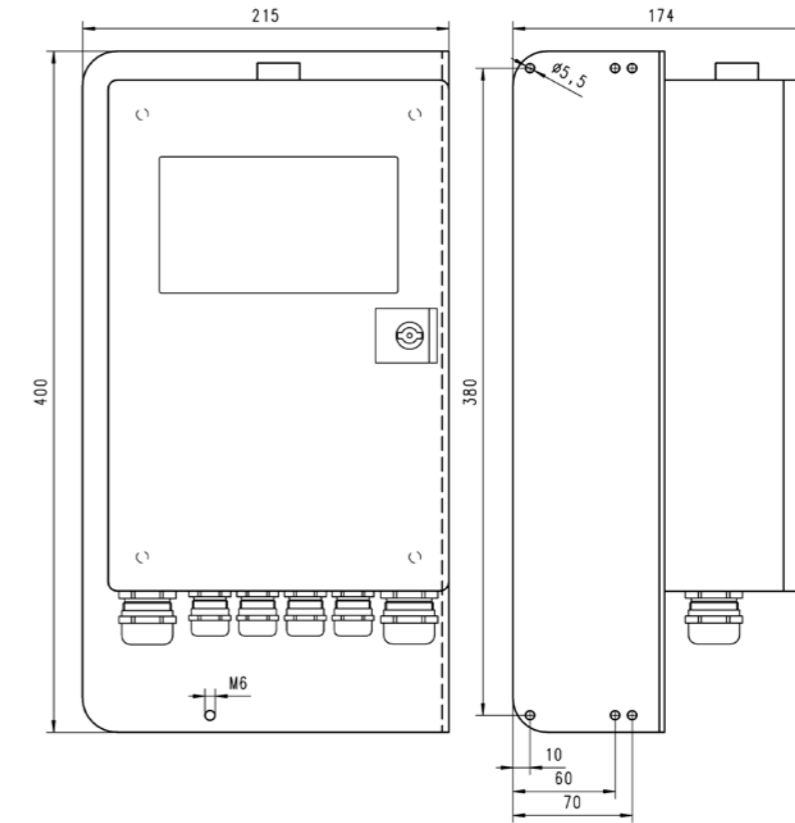

Cable glands wired by PB:

- M25: Padwear1, Padwear2, Stroke, Force
- M12: Temperature 1
- M20: Release, Manual Release
- M20: Speed, Temperature 2
- M12: spare

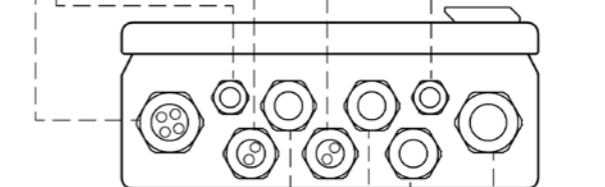

Cable glands for customer:

- M20: Supply voltage, max cable diameter 13 mm
- M25: Signals to crane, max cable diameter 17 mm

Remark: Force, Profibus In and Out only for CMB2

Monitoring System VSR2-SB

Dimensions and technical data



Rev. 05-16

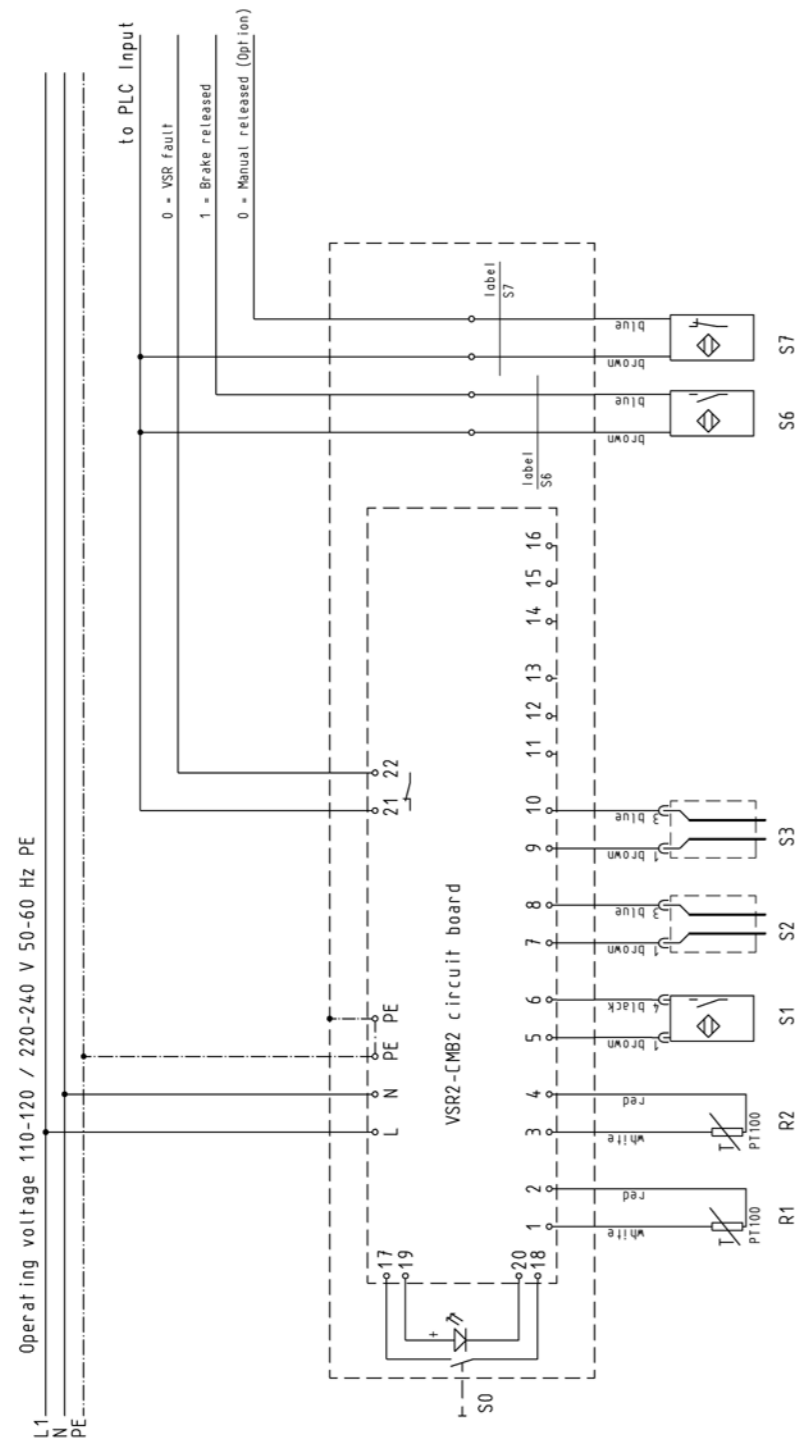

- Part list:
- S0 Reset button with LED lamp
 - R1 Brake pad 1 temperature sensor
 - R2 Brake pad 2 temperature sensor
 - S1 Stroke sensor
 - S2 Pad 1 wear sensor
 - S3 Pad 2 wear sensor
 - S6 Proximity switch brake release control 20-240 V AC/DC
 - S7 Proximity switch hand release control 20-240 V AC/DC (Option)

Monitoring System CMB-3 for SB brakes



PINTSCH BUBENZER
is certified according to
DIN EN ISO 9001:2015

Permanent monitoring of



Release Stroke



Brake Force

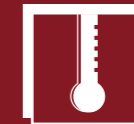

Lining Temperature



Lining Wear

F

Description CMB-3 for SB brakes



Parts of the system

- Supply voltage:** The electronic unit can be connected directly to 110-240 V AC (50/60 Hz) supply voltage
- Display:** All measured analogue and digital signals and error messages are shown on the display in English language. Other languages are available on request. The display is readable under direct sunshine (outdoor and container crane applications) and has a LED backlight for use in a dark environment, such as steel mills
- Keypad:** With the internal key pad, the user can adjust parameters such as changing the temperature display from Celsius (°C) to Fahrenheit (°F) or setting of the Profibus address
- Reset button:** The LED pushbutton on top of the electronic box indicates that the brake is outside its normal operating parameters by a flashing red light. When the problem on the brake is solved, the status of the CMB3-SB can be reset by pushing the button. The unit cannot be reset until the adjustments are made and the problem solved
- Force sensors:** One load cell pin, located in the top of one brake lever, measures the contact force in the closed condition of the brake. This signal is used to detect an incorrect setting or a broken spring
- Stroke sensors:** The analogue sensor measures the position of the thruster piston rod. The reserve stroke is measured and checked that it is at the perfect position of 10 mm when the brake is correctly closed. The maximum measurement range is 100 mm
- Proximity switch release control:** This switch and the optional manual release switch are independent from the CMB3-SB and have to be connected to the control plc

- Relay contact:** A dry contact (max 250 V 2 A) is connected to terminals 21/22. It is closed in normal status and open, if the system is in error mode, or switched off. If no Profibus or Profinet is available, this contact can be connected to main control PLC input, to give a common error signal
- Profibus or Profinet:** All scaled measured data and warning signals are transferred by the Profibus-DP slave port to the main control PLC. No expensive analogue inputs (6 pcs. per brake) are required in PLC. The address of the DP slave can be easily set in the unit by a parameter change in the software. Up to 126 brakes can be connected to one Profibus master

Main Features

- One CMB-3 box can handle up to 2 brakes SB28 / SB23 / SB16
- High ambient temperature range -20°C ... +70°C
- Protection class IP65
- Internal keypad for parameter change
- Brake operation cycle counter (up to 100 million Cycles)
- Automatic power supply range switch 110-240 V AC
- Profibus or Profinet bus system possible
- All scaled measures signals and error bits are transferred by bus system to the main control PLC. No expensive analogue inputs are required in control PLC
- Cable for sensors have a plug M12 on each end for easy troubleshooting
- Same type of box for SF and SB brake types

Options

- Stainless steel electronic box IP65 for outdoor use
- Sunshine protection cover for outdoor use

Monitoring System CMB-3 for SB brakes

Dimensions and technical data



Rev. 09-15

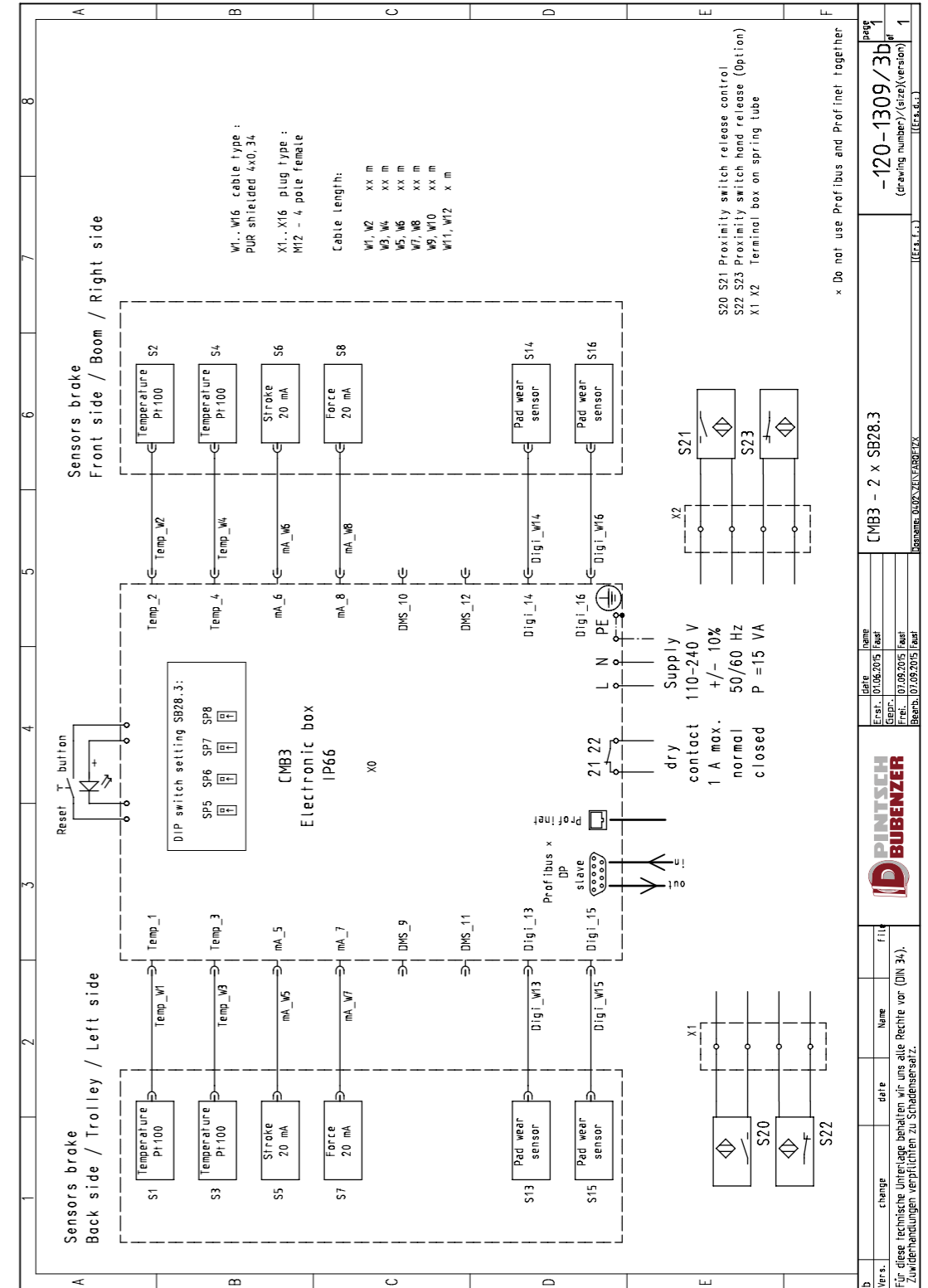

All these raw sensor readings are scaled by the CMB unit to physical values, showed in the integrated display and transmitted for visualization to the crane CMS.



PINTSCH BUBENZER
is certified according to
DIN EN ISO 9001:2015

F

Permanent monitoring of



Thruster Stroke



Brake Force

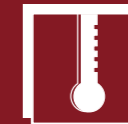

Lining Temperature



Lining Wear

Description CMB-3 for SF brakes



Parts of the system

- Supply voltage:** The electronic unit can be connected directly to 110-240 V AC (50/60 Hz) supply voltage
- Display:** All measured analogue and digital signals and error messages are shown on the display in English language. Other languages are available on request. The display is readable under direct sunshine (outdoor and container crane applications) and has a LED backlight for use in a dark environment, such as steel mills
- Keypad:** With the internal key pad, the user can adjust parameters such as changing the temperature display from Celsius (°C) to Fahrenheit (°F) or setting of the Profibus address
- Reset button:** The LED pushbutton on top of the electronic box indicates that the brake is outside its normal operating parameters by a flashing red light. When the problem on the brake is solved, the status of the CMB3-SF can be reset by pushing the button. The unit cannot be reset until the adjustments are made and the problem solved
- Pad temperature sensor:** A pair of Pt100 sensors (R1, R2) measure the temperature of each brake pad. If the temperature is too high, or unequal between left, or right hand side the unit generates a signal that can be sensed by the main control PLC to warn the operator that attention is required
- Contact force sensor:** A load cell located in each brake cylinder (S3 S4) measures the contact force of the spring pack. This signal is used to detect a spring failure or malfunction of the hydraulic system
- Stroke sensor:** These analogue sensors (S1, S2) measure the stroke of the piston. If the rated stroke of 2 mm/side increases beyond the maximum value due to pad wear. If the value is higher than 2.5 mm, the customer should readjust the stroke back to 2.0 mm in accordance with the manual. Failure to do so can result in a reduced braking performance. Again a signal bit is set to flag the problem to the control PLC

- Proximity switch release control:** These 2 switches (S5 S6) are independent from the CMB3-SF and have to be connected directly to the main control PLC to be active
- Relay contact:** A dry contact (max 250 V 2 A) is connected to terminals 21/22. It is closed in normal status and open, if the system is in error mode, or switched off. If no Profibus or Profinet is available, this contact can be connected to main control PLC input, to give a common error signal
- Profibus or Profinet:** All scaled measured data and warning signals are transferred to the main control PLC. No expensive analogue inputs (6 pcs. per brake) are required in PLC

Main Features

- One CMB-3 box can handle up to 2 brakes SF10...SF40, 1 dual caliper brake SF50
- High ambient temperature range -20°C ... +70°C
- Protection class IP65
- Internal keypad for parameter change
- Brake operation cycle counter (up to 100 million Cycles)
- Automatic power supply range switch 110-240 V AC
- Profibus or Profinet bus system possible
- All scaled measures signals and error bits are transferred by bus system to the main control PLC. No expensive analogue inputs are required in control PLC
- Cable for sensors have a plug M12 on each end for easy troubleshooting
- Same type of box for SF and SB brake types

Options

- Stainless steel electronic box IP65 for outdoor use
- Sunshine protection cover for outdoor use

Monitoring System CMB-3 for SF brakes

Dimensions and technical data



Rev. 04-15

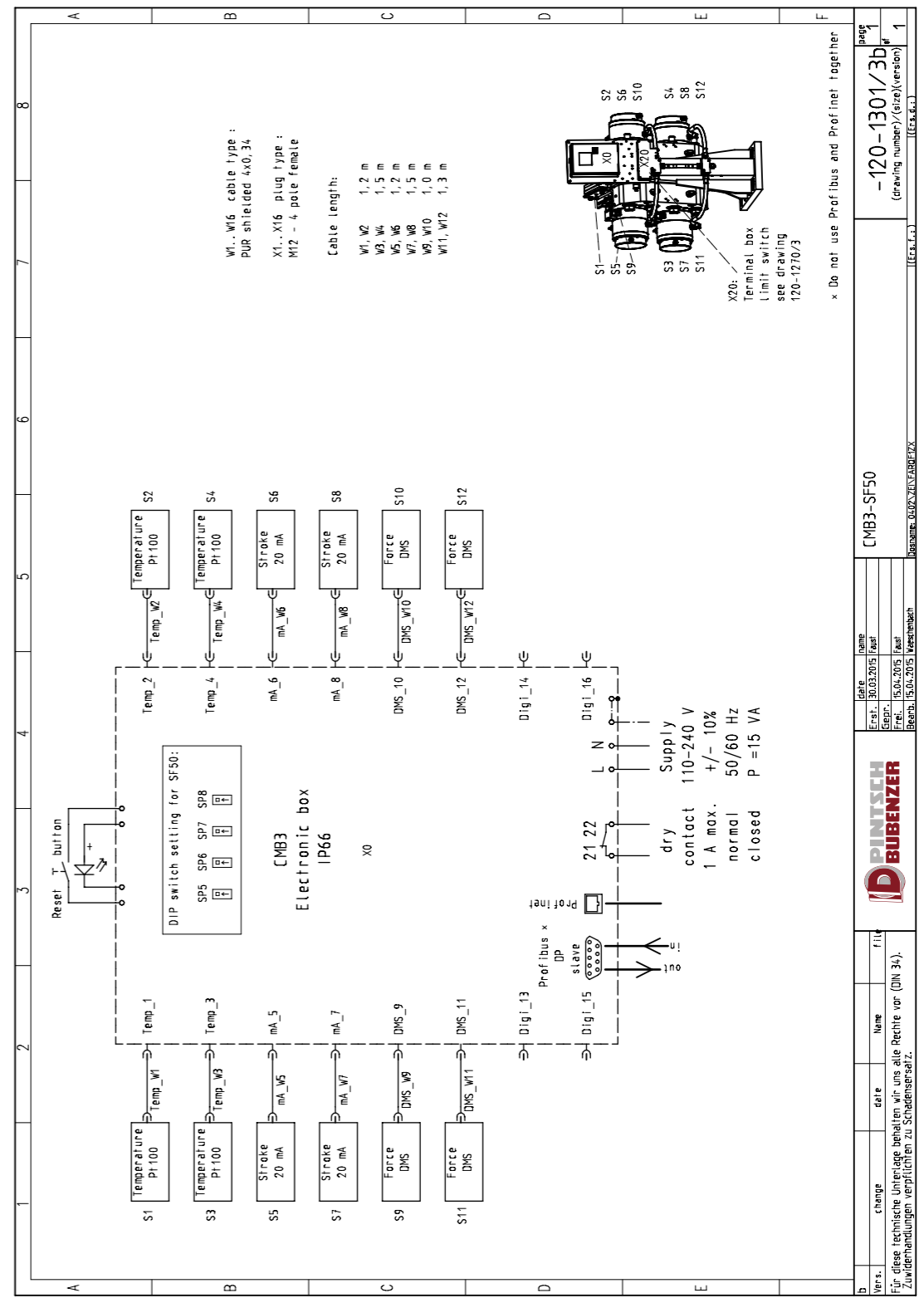

Please Note

All these raw sensor readings are scaled by the CMB unit to physical values, showed in the integrated display and transmitted for visualization to the crane CMS.

Description BB 900

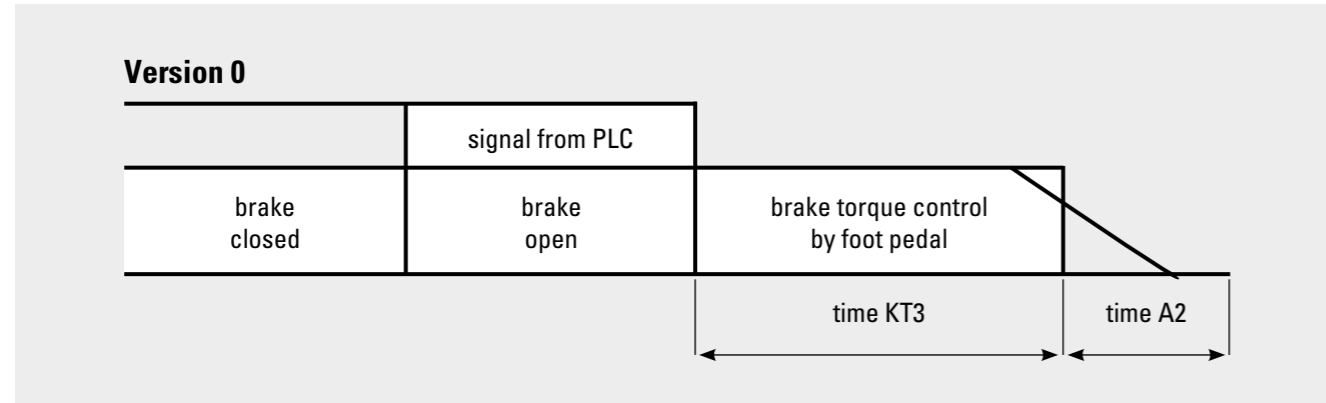

Version 1

Foot pedal with two limit switches. Actuation of the foot pedal switches off the drive motor and allows braking control with the pedal. When the pedal is depressed to the full extent, the brake remains closed until the customer's master switch is actuated once more

All frequency converter units as standard with:

Steel enclosure for use under harsh environmental conditions (600x600x210mm)

Main power input filter for filtering out main disturbances

Filter for reducing voltage spikes of the electro-hydraulic brake thrusters and eliminating EMV problems

Version 2

Two operating modes, accessed by the customer's selector switch

1. Direct opening and closing of the brake without time delay

2. Direct opening of the brake; Closing of the brake with adjustable time delay. During this time delay, braking can be carried out by the foot pedal

Ordering Example

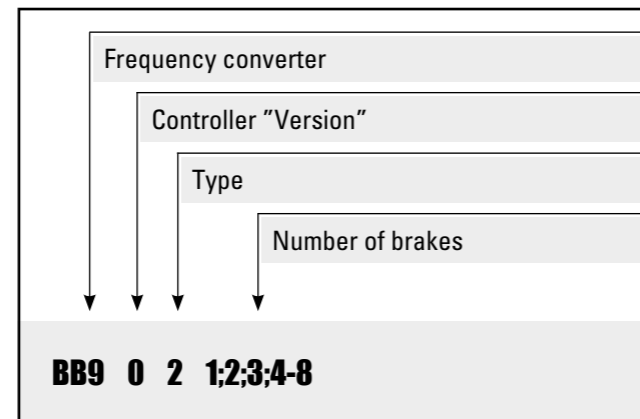

Version 3

Customer's current (4...20 mA) or voltage signal (0...10 V) for the stepless control of the brake torque (without foot pedal)

Foot Pedal

for electric operated brakes



Rev. 09-02

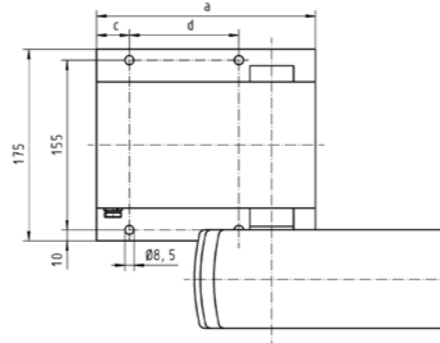
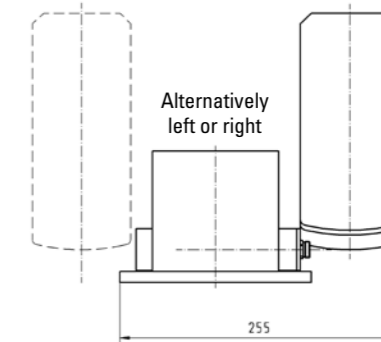
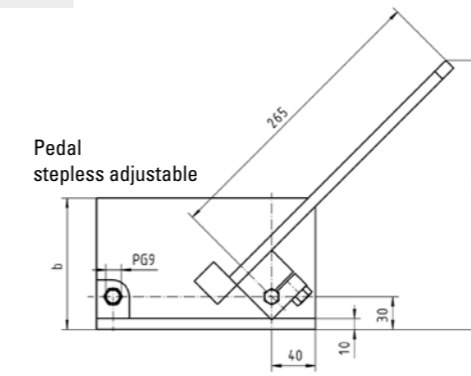

Electr. Foot Pedal "A" for installation on top cabin floor					
Execution	a	b	c	d	Weight kg
Foot pedal "A" for max. 2 brakes	200	120	30	100	7,8
Double foot pedal "A" for max. 4 brakes	275	135	33	175	9,2

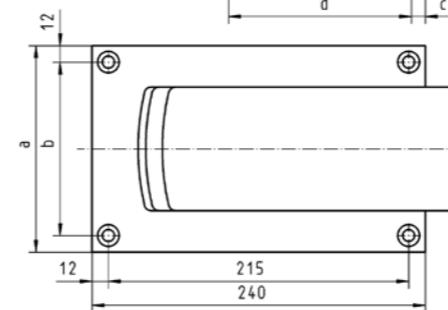
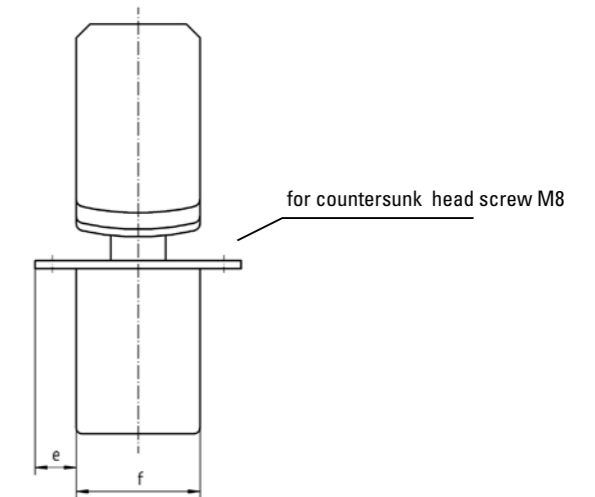
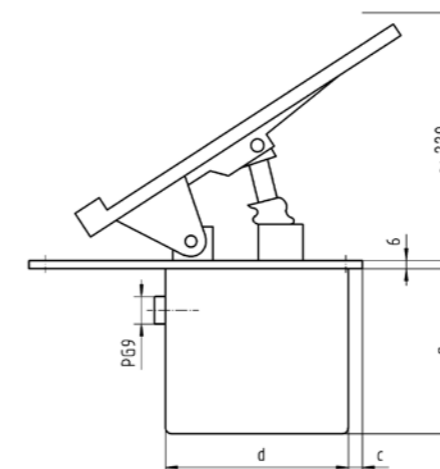

Electr. Foot Pedal "B" for installation into the cabin floor								
Execution	a	b	c	d	e	f	g	Weight kg
Foot pedal "B" for max. 2 brakes	150	125	10	135	25	85	95	4,7
Double foot pedal "B" for max. 4 brakes	224	195	25	145	22	180	105	6,8

Description BSZ



Main Features

- Rail clamp spring applied
- Apply time: Continuously adjustable 3-12 seconds
- Rail clamp hydraulically released
- Hand pump for emergency release
- Integrated hydraulic power unit, ready piped and wired to terminal box
- Limit switch release control, mechanical or proximity type
- Connection by flange on end face (BSZ/II)
- Connection by flange on top (BSZ/III)
- Static applications
- Holding forces 100-400 kN
- Lateral compensation ± 10 mm

Options

- Special mounting dimensions
- Holding forces up to 1000 kN
- Lateral compensation ± 25 mm
- Vertical compensation ± 25 mm
- Buffer connection
- Rail sweeper
- Operation of several rail clamps by one hydraulic power unit
- Enclosures of stainless steel

Applications

As storm brake on all rail mounted equipment, e. g. cranes, stackers, reclaimers etc. Particularly when the rail is mounted above dock level or a rail channel is provided

Operating Restrictions

Rail clamps of this range are tested both mechanically and hydraulically and are set to nominal force. This setting can only be changed by the manufacturer. Operating conditions other than described in this brochure require the manufacturer's approval and may influence the function of the rail clamp and its components

Ordering Example

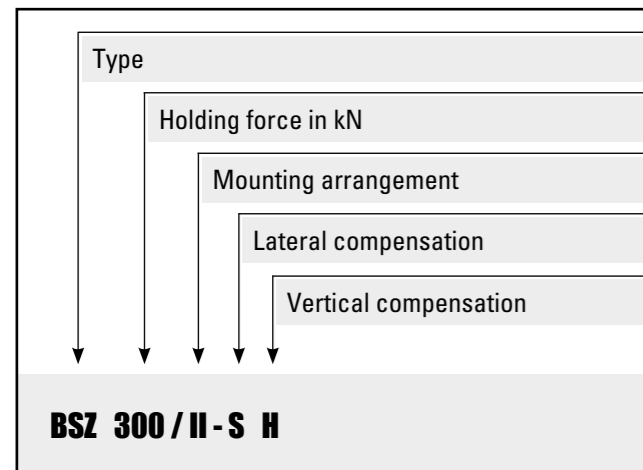

Rail Clamp BSZ/II

Dimensions and technical data



Rev. 10-08

Connection in combination with a flange on the end face

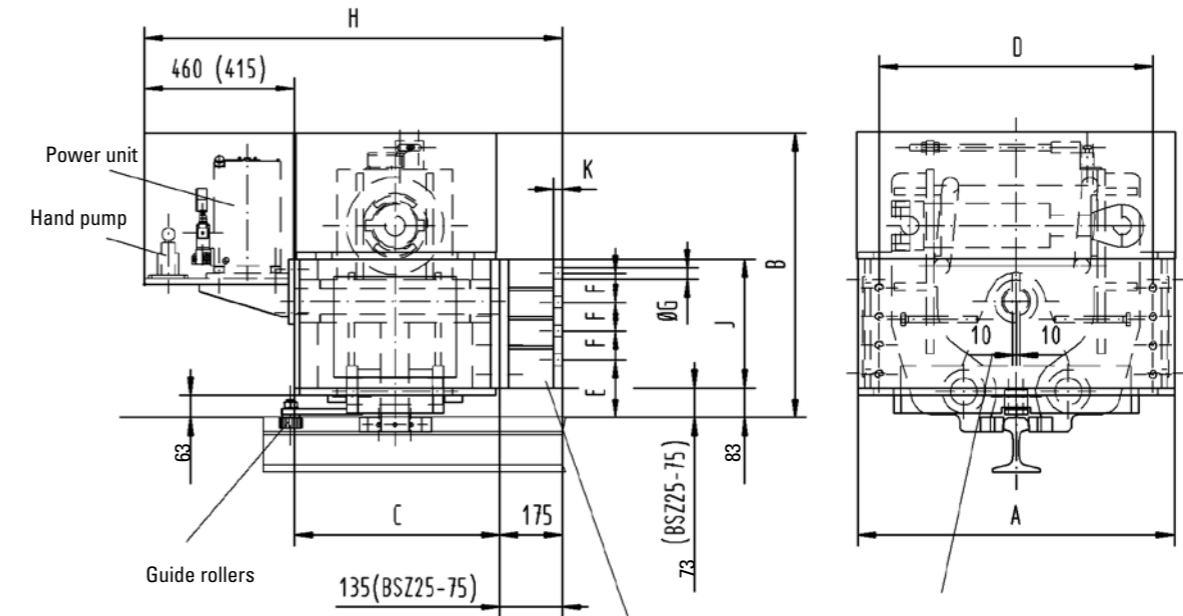

Lateral compensation ± 10 mm

Dimensions D,E,F,G,n and J by customer data or by table

n = Quantity of fixing holes

Type	Holding force kN	All dimensions in mm Alterations reserved without notice										
		A	B	C	D	E	F	G	H	J	n	K
BSZ 25/II	25	650	745	295	500	120	105	17	820	305	6	15
BSZ 50/II	50	650	745	295	500	120	105	21	820	305	6	20
BSZ 75/II	75	650	745	295	500	120	105	21	820	305	6	20
BSZ 80/II	80	690	755	470	500	133	100	21	1060	415	8	25
BSZ 100/II	100	690	755	470	500	133	100	26	1060	415	8	25
BSZ 120/II	120	690	755	470	500	133	100	26	1060	415	8	25
BSZ 140/II	140	690	755	470	500	133	100	30	1060	415	8	25
BSZ 150/II	150	880	790	575	800	120	90	30	1170	358	8	25
BSZ 200/II	200	880	790	575	800	120	90	33	1210	358	8	25
BSZ 250/II	250	880	790	575	800	120	90	33	1210	358	8	25
BSZ 300/II	300	880	790	575	800	120	90	33	1210	358	8	25
BSZ 400/II	400	880	790	575	800	120	90	33	1210	358	8	25



Please Note

We supply a detailed operating manual with every order. Nevertheless, we would point out that rail clamps are only as safe as the servicing and maintenance performed while they are in operation. The guarantee for the correct functioning of our rail clamps is therefore only valid if the user adheres to the German DIN standard 15019 part 1, table 5. Do not use rail clamps as dynamic brakes.



PINTSCH BUBENZER Service

This includes the installation and commissioning on site by PINTSCH BUBENZER service engineers, if required. Drawings as DWG/DXF files for your engineering department are available upon request.

Rail Clamp BSZ/II-SH

Dimensions and technical data



Rev. 10-08

Connection in combination with a flange on the end face

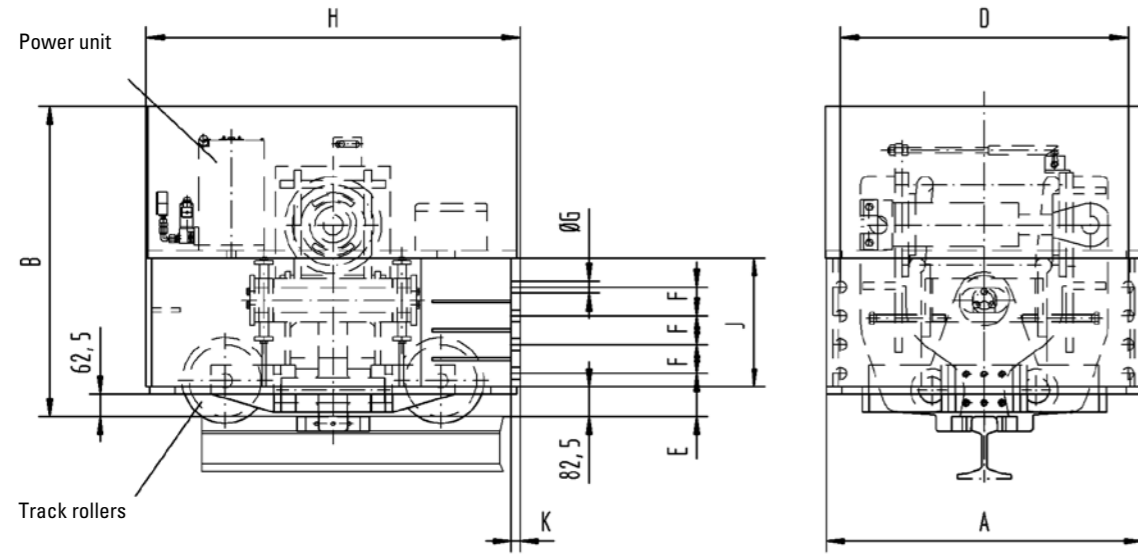

Vertical compensation ± 25 mm
Lateral compensation ± 25 mm

Dimensions D,E,F,G,n and J by customer data or by table

n = Quantity of fixing holes
m = ca. weight in kg

All dimensions in mm
Alterations reserved without notice

Type	Holding force		A	B	D	E	F	G	H	J	n	K	m
	kN												
BSZ 80/II	80		880	865	800	120	80	26	1040	368	8	25	780
BSZ 100/II	100		880	865	800	120	80	26	1040	368	8	25	820
BSZ 120/II	120		880	865	800	120	80	30	1040	368	8	25	830
BSZ 140/II	140		880	865	800	120	80	30	1040	368	8	25	830
BSZ 150/II	150		880	910	800	120	90	33	1115	368	8	25	1000
BSZ 200/II	200		880	910	800	120	90	33	1115	368	8	25	1060
BSZ 250/II	250		880	910	800	120	90	33	1115	368	8	25	1060
BSZ 300/II	300		880	910	800	120	90	33	1115	368	8	25	1060
BSZ 400/II	400		880	910	800	120	90	33	1115	368	8	25	1100

Rail Clamp BSZ

Electric diagram



Rev. 09-02

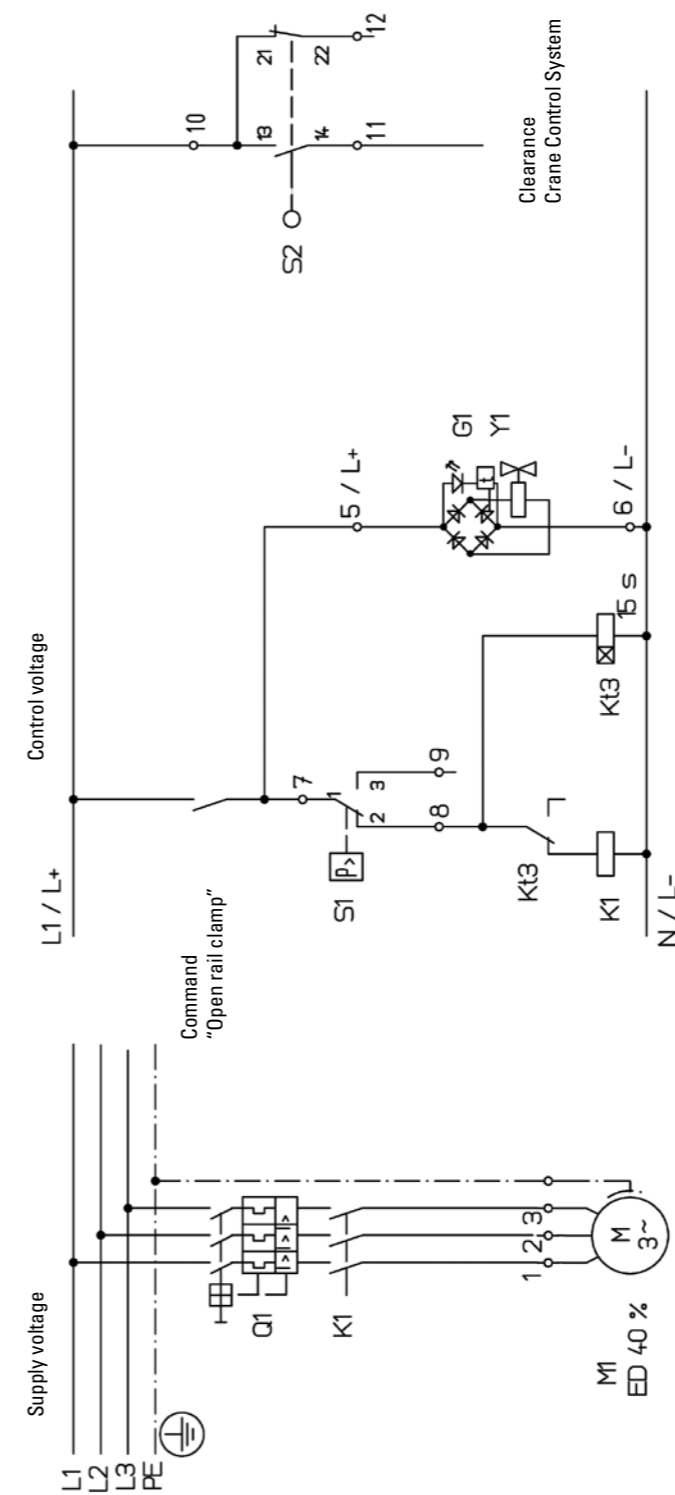

PINTSCH BUBENZER scope of supply	
M1	Hydraulic motor 3 Ph, ED = 40%
Y1	Solenoid valve
G1	Plug
S1	Pressure switch
S2	Limit switch release control

Alterations reserved without notice

Rail Clamp BSZ

Mounting position and rail arrangement



Rev. 07-17

Mounting position buffer and rail sweeper

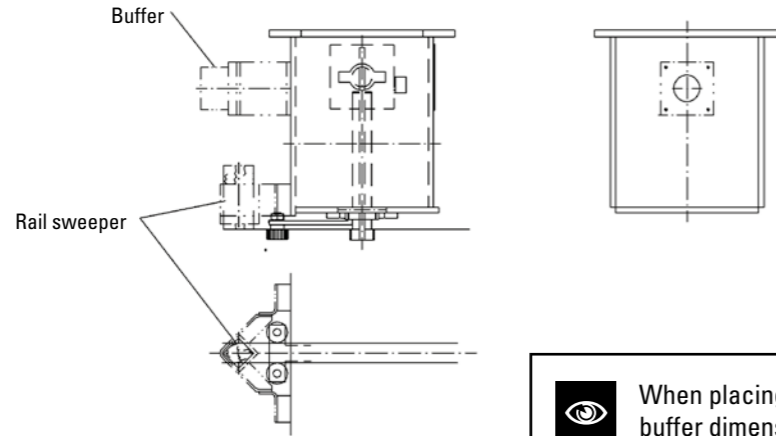

When placing order please indicate buffer dimensions and buffer force.

Mounting position hydraulic power unit

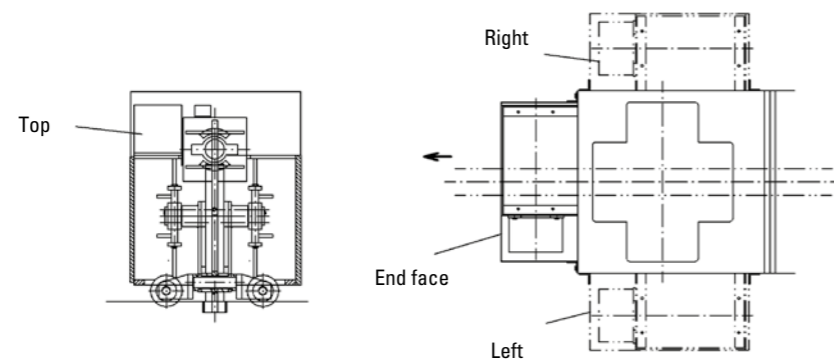

Rail arrangement

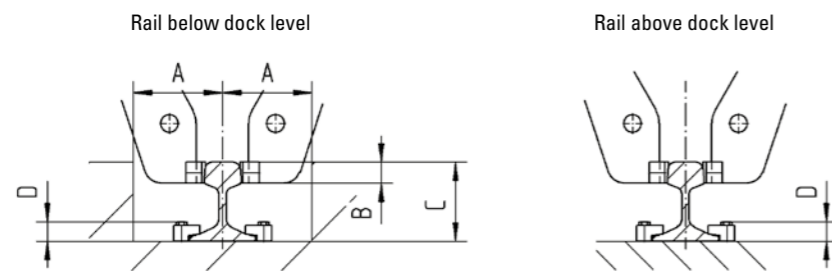

Alterations reserved without notice

When placing order please indicate dimensions A, B, C and D.

Rail Clamp BSZ/III

Dimensions and technical data



Rev. 10-08

Connection in combination with a flange on top

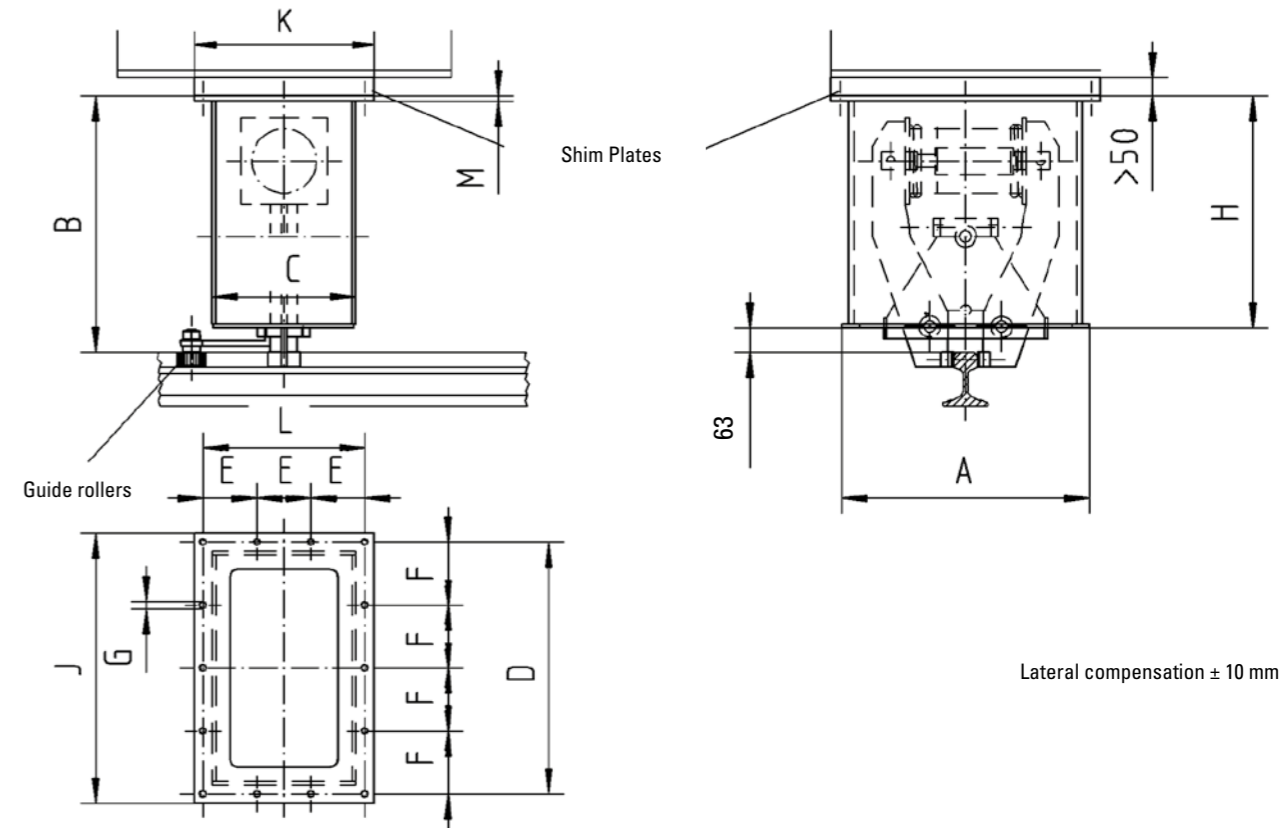

All dimensions in mm
Alterations reserved without notice

Type	Holding force kN	All dimensions in mm Alterations reserved without notice												
		A	B	C	D	E	F	G	H	J	K	L	M	
BSZ 25/III	25	640	698	390	700	150	175	22	635	750	500	450	20	
BSZ 50/III	50	640	698	390	700	150	175	22	635	750	500	450	20	
BSZ 75/III	75	640	698	390	700	150	175	22	635	750	500	450	20	
BSZ 80/III	80	600	750	600	660	100	110	26	687	720	660	600	20	
BSZ 100/III	100	600	750	600	660	100	110	26	687	720	660	600	20	
BSZ 120/III	120	600	750	600	660	100	110	26	687	720	660	600	25	
BSZ 140/III	140	600	750	600	660	100	110	26	687	720	660	600	25	
BSZ 150/III	150	900	823	720	950	162	190	26	760	1040	900	810	30	
BSZ 200/III	200	900	823	720	950	162	190	26	760	1040	900	810	30	
BSZ 250/III	250	900	823	720	950	162	190	26	760	1040	900	810	30	
BSZ 300/III	300	900	823	720	950	162	190	26	760	1040	900	810	30	
BSZ 400/III	400	900	823	720	950	162	190	26	760	1040	900	810	30	

Rail Clamp BSZ

Hydraulic diagram



Rev. 09-02

Q:	4,25 l/min (50 Hz) 5,1 l/min (60 Hz)
p:	250 bar (50Hz) 210 bar (60Hz)
P:	1,1 kW (50 Hz) 1,3 kW (60Hz)
Control voltage:	24 V DC 110 V AC 230 V AC
Supply voltage:	360-440 V AC (50Hz) 380-480 V AC (60Hz)
Tank capacity:	5 Litres

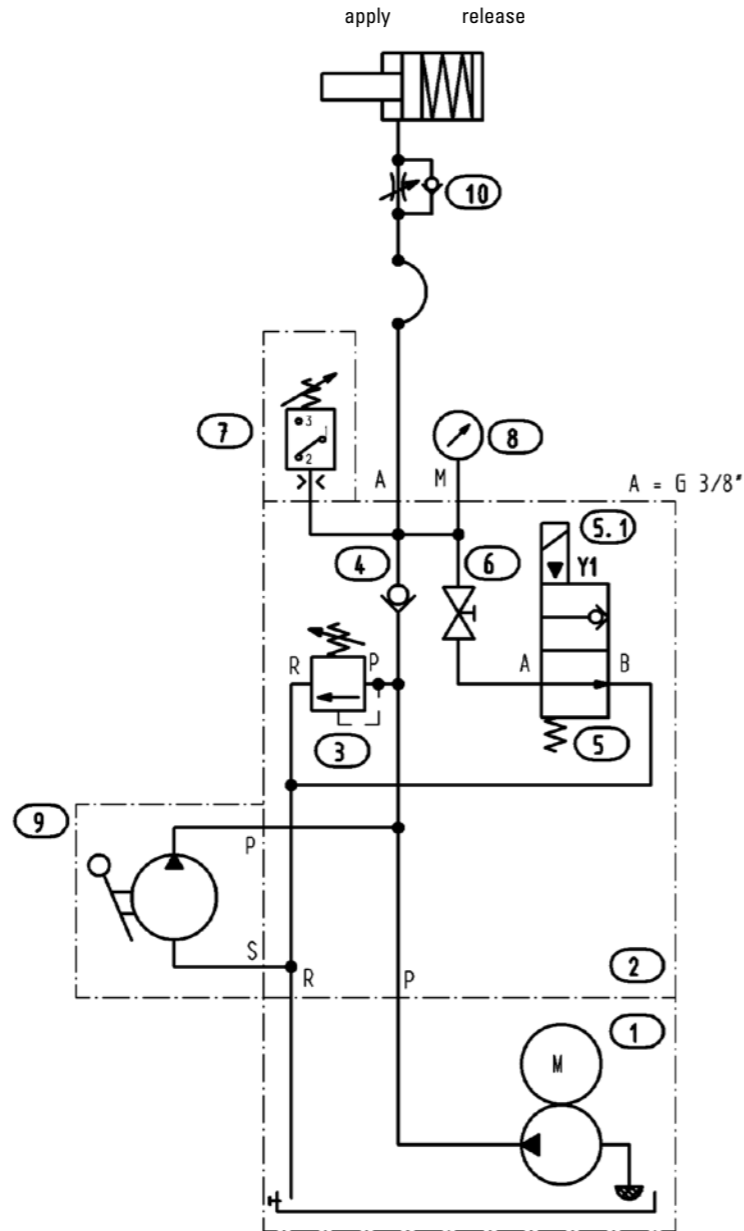

Pos	Qty	Designation
1	1	Hydraulic power unit
2	1	Manifold block
3	1	Pressure valve
4	1	Check valve
5	1	2/2 valve
5.1	1	Plug
6	1	Cock
7	1	Pressure switch
8	1	Pressure gauge
9	1	Hand pump
10	1	Throttle check valve

Alterations reserved without notice

Rail Brake Type BSB



PINTSCH BUBENZER
is certified according to
DIN EN ISO 9001:2015



Easy Maintenance



High Performance



No Rail Channel
Required



Reliable – Long Life
Spring Package



Tried and Trusted

Description BSB



Main Features

- Rail brake spring applied
- Apply time: Continuously adjustable 3-12 seconds
- Rail brake hydraulically released by **external** release cylinders
- Limit switch release control, mechanical or proximity type
- Connection by flange on top
- Static applications
- Holding forces 100-300 kN
- Vertical compensation ± 10 mm

Ordering Example

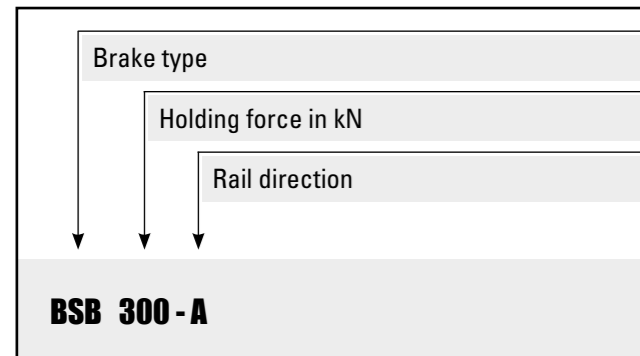

Options

- Operation of several rail brakes by one hydraulic power unit, including hand pump for emergency release
- Stainless steel enclosures for power unit and terminal box
- Space heater, oil level and oil temperature switch for the power unit
- Complete piping set, if required, in stainless steel

Applications

- As storm brake on all rail mounted equipment, e. g. cranes, stackers, reclaimers etc. Particularly when the rail is mounted above dock level or a rail channel is provided

Operating Restrictions

- Brakes of this range are tested both mechanically and hydraulically and are set to nominal force. This setting can only be changed by the manufacturer. Operating conditions other than described in this brochure require the manufacturer's approval and may influence the function of the brake and its components

Rail Brake BSB

Dimensions and technical data



Rev. 11-03

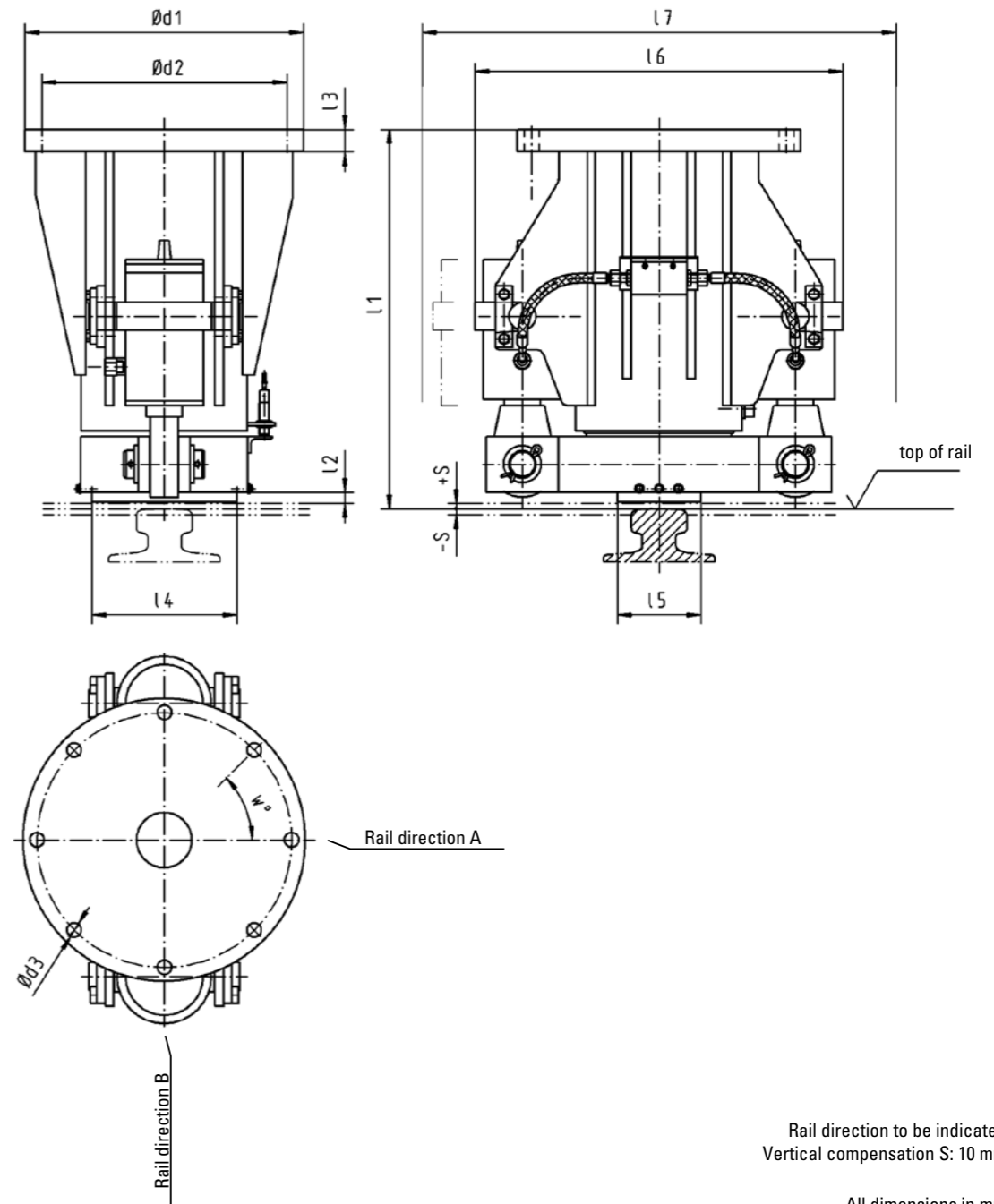

Rail direction to be indicated
Vertical compensation S: 10 mm

All dimensions in mm
Alterations reserved without notice

Type	Holding force	d1	d2	d3	l1	l2	l3	l4	l5	l6	l7	W°
BSB 100	100 kN	508	457	27	576	20	40	260	150	660	850	45
BSB 150	150 kN	508	457	27	576	20	40	260	150	660	850	45
BSB 200	200 kN	520	457	31	710	16	40	260	150	660	850	30
BSB 250	250 kN	600	530	37	950	10	40	300	150	855	1060	22,5
BSB 300	300 kN	600	530	37	950	10	40	300	150	855	1060	22,5



Please Note

We supply a detailed operating manual with every order. Nevertheless, we would point out that rail brakes are only as safe as the servicing and maintenance performed while they are in operation.



PINTSCH BUBENZER Service

This includes the installation and commissioning on-site by PINTSCH BUBENZER service engineers, if required. Drawings as DWG/DXF files for your engineering department are available upon request.

Rail Brake BSB

Hydraulic power unit for one or more brakes



Rev. 12-06

Type example

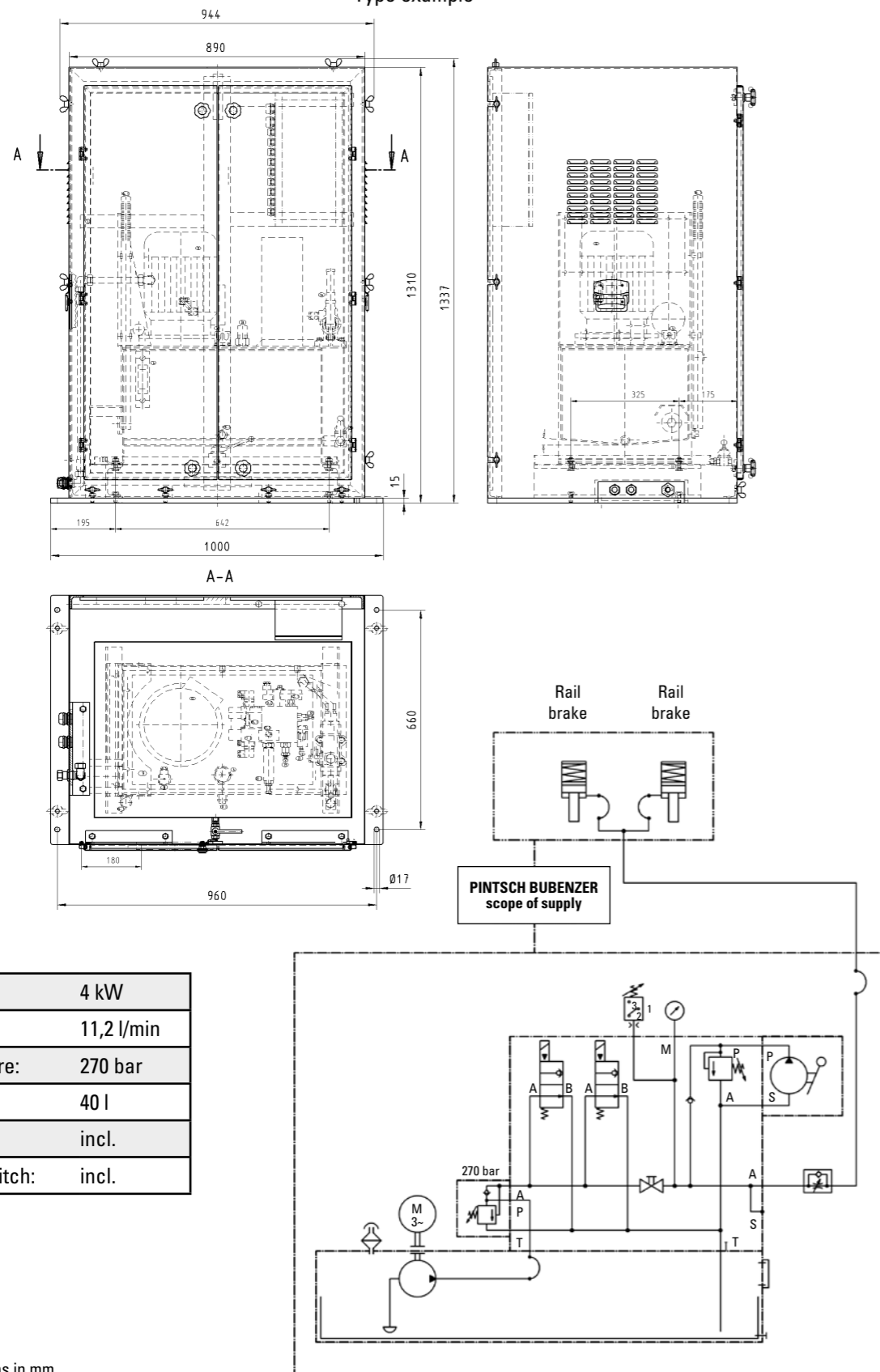

Motor:	4 kW
Pump:	11,2 l/min
Max. pressure:	270 bar
Oil tank:	40 l
Hand pump:	incl.
Pressure switch:	incl.

All dimensions in mm
Alterations reserved without notice

Piping Sample

Rail Brake BSB



Rev. 09-02

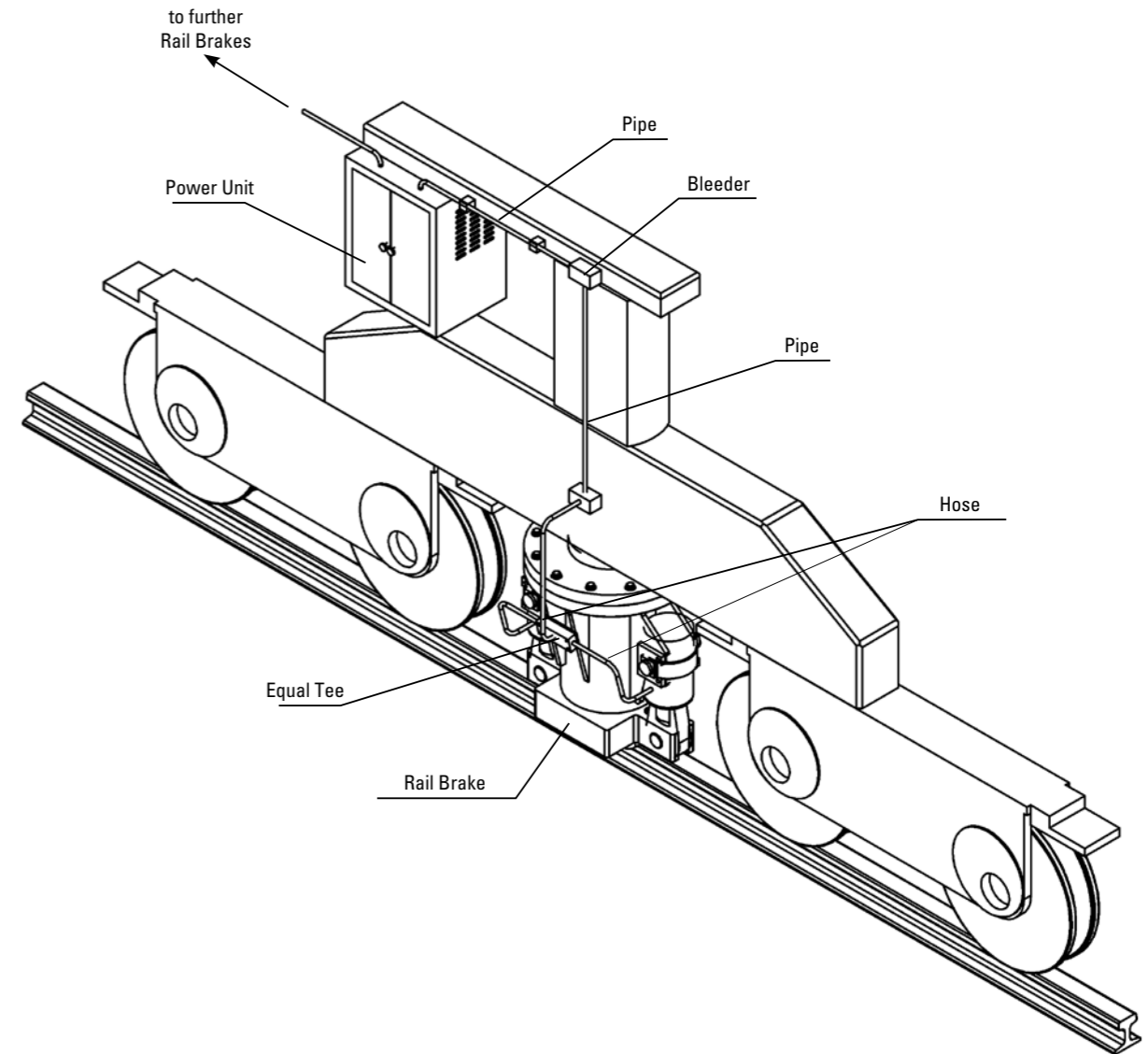

Attention: For operating two or more brake units with one power unit please note, that the power unit should be installed between the brakes in the centre to achieve almost equal pipe length on both sides (equal apply time of brakes).

G

Description PB Buffer



Main Features

- Piston and cylinder of special seamless pipes
- Back mounted or front mounted versions available
- Piston rod IONIT-OX coated (plasma nitriding process)
- Impact speed sensitive damping
- Low maintenance

Options

- Special mounting flanges on request
- Special high and low temperature design
- Safety wire rope
- Protection bellows
- Special design on request
- Seawater resistant paint on request

Ordering Example

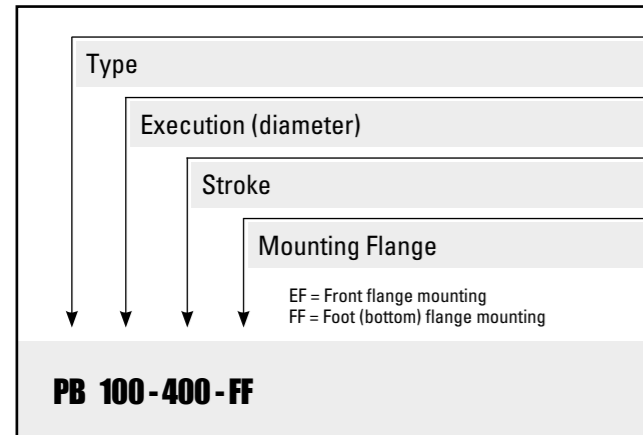

Applications

As impact energy absorber on crane gantries, trolleys, elevators, stackers, reclaimers and other industrial equipment

Buffer Type PB 50

Dimensions and technical data



Rev. 01-16

Type FF:

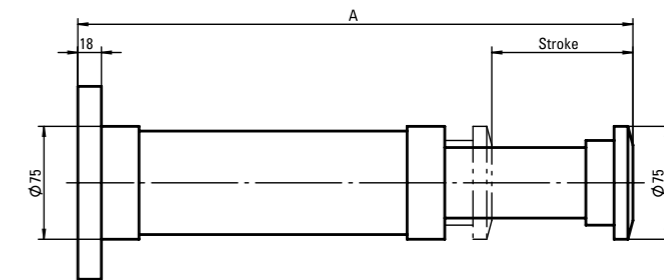

Type EF:

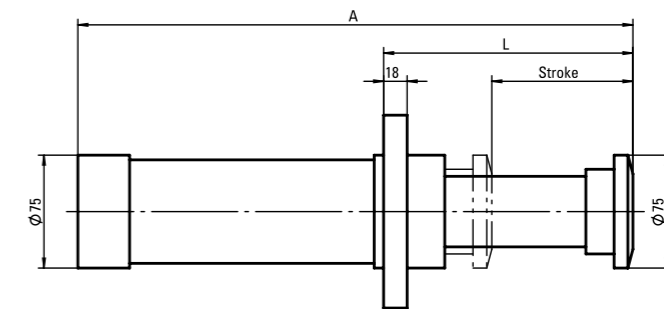

Flange:

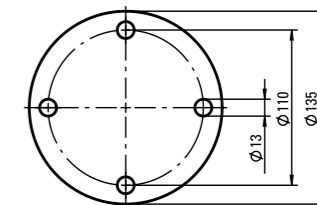

EF = front flange mounting
FF = foot (bottom) flange mounting

All dimensions in mm
Alterations reserved without notice

Stroke	Energy Stroke	* Energy h	Max. buffer force	Inward force	Weight	** Perm. angular deviation	** Perm. angular deviation	A	L
EF FF mm	EF FF kNm (kJ)	EF FF kNm (kJ)	EF FF kN	EF FF kN	EF FF kg	FF degree	EF degree	EF FF mm	EF mm
50	4,5	400	100	5,0	6,6	4,5	5,5	270	145
100	9,0	650	100	6,0	8,2	3,2	4,0	410	195
150	13,6	950	100	6,0	9,8	2,1	2,9	550	245
200	18,1	1250	100	7,0	11,2	1,5	2,3	685	295
250	22,7	1600	100	7,0	12,6	1,3	2,1	825	345
300	27,2	1900	100	7,0	14,0	1,2	1,9	965	395
350	28,6	2000	90	7,0	15,5	1,1	1,8	1105	445
400	29,0	2100	80	7,5	16,9	1,0	1,7	1235	495
450	28,6	2200	70	7,5	18,2	-	1,6	1375	545
500	27,2	2200	60	7,5	19,5	-	1,5	1515	595

* At an ambient temperature of 30°C
** Relating to the max. permissible buffer force



Please Note

We supply a detailed operating manual with every order. Nevertheless, we would point out that buffers are only as safe as the servicing and maintenance performed while they are in operation. The guarantee for the correct functioning of our buffers is therefore only valid if the user adheres to the installation and operating manual.



PINTSCH BUBENZER Service

This includes the verification of the brake selection, if required. A detailed questionnaire is provided for this purpose. Installation and commissioning on-site by PINTSCH BUBENZER service engineers is possible. Drawings as DWG/DXF files for your engineering department are available upon request.

Buffer Type PB 63

Dimensions and technical data



Rev. 02-16

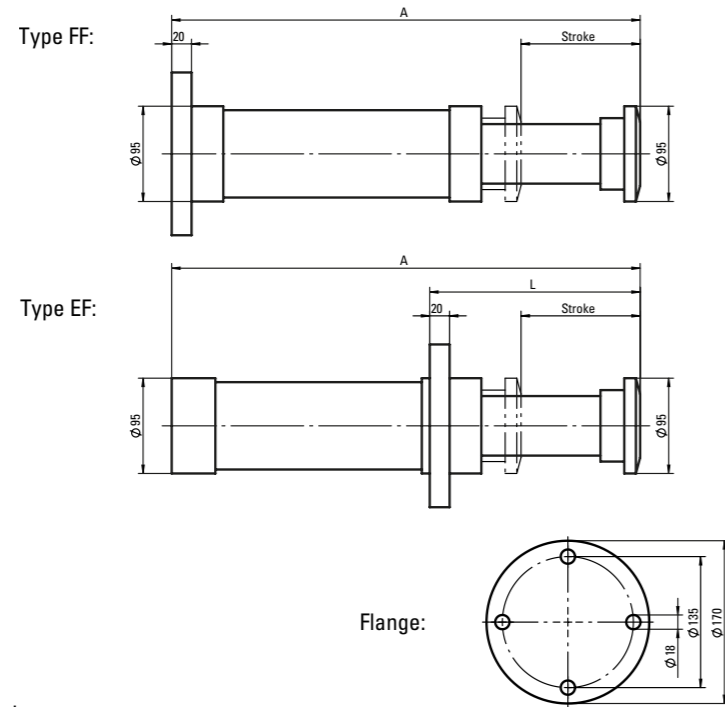

EF = front flange mounting
FF = foot (bottom) flange mounting

All dimensions in mm
Alterations reserved without notice

Stroke	Energy Stroke	* Energy h	Max. buffer force	Inward force	Weight	** Perm. angular deviation	** Perm. angular deviation	A	L
EF FF mm	EF FF kNm (kJ)	EF FF kNm (kJ)	EF FF kN	EF FF kN	EF FF kg	FF degree	EF degree	EF FF mm	EF mm
50	7,7	600	170	8,0	10,5	4,2	5,0	280	155
100	15,4	1200	170	8,0	13,5	3,2	4,0	425	205
150	23,1	1600	170	9,0	16,0	2,2	3,0	560	255
200	30,9	1850	170	10,0	18,0	1,8	2,4	700	305
250	38,6	2100	170	11,0	20,5	1,6	2,2	835	355
300	46,3	2400	170	11,0	23,0	1,5	2,1	975	405
350	50,9	2600	160	12,0	25,5	1,4	2,0	1115	455
400	54,5	2800	150	12,0	28,0	1,3	1,9	1255	505
450	57,2	2900	140	12,0	30,5	1,2	1,8	1395	555
500	59,0	3000	130	12,0	33,0	1,1	1,6	1535	605
550	60,0	3000	120	15,0	35,0	-	1,5	1650	655
600	60,0	3000	110	15,0	37,0	-	1,4	1785	705
650	59,0	3000	100	15,0	39,5	-	1,3	1925	755
700	57,2	3200	90	15,0	42,0	-	1,2	2060	805
750	54,5	3200	80	15,0	44,5	-	1,1	2200	855
800	50,9	3200	70	15,0	47,0	-	1,0	2340	905

* At an ambient temperature of 30°C
** Relating to the max. permissible buffer force

Buffer Type PB 80

Dimensions and technical data



Rev. 02-16

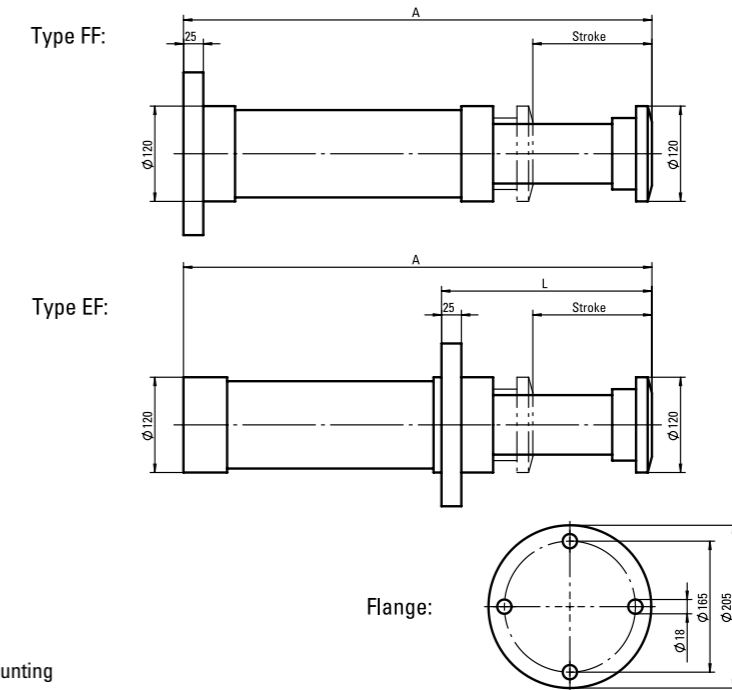

EF = front flange mounting
FF = foot (bottom) flange mounting

All dimensions in mm
Alterations reserved without notice

Stroke	Energy Stroke	* Energy h	Max. buffer force	Inward force	Weight	** Perm. angular deviation	** Perm. angular deviation	A	L
EF FF mm	EF FF kNm (kJ)	EF FF kNm (kJ)	EF FF kN	EF FF kN	EF FF kg	FF degree	EF degree	EF FF mm	EF mm
50	11,8	600	260	12,0	20	4,2	5,5	290	175
100	23,6	1000	260	12,0	24	24	4,8	440	225
150	35,4	1700	260	12,0	28	28	4,0	590	275
200	47,2	2200	260	12,0	33	33	3,2	740	325
250	59,0	2600	260	15,0	36	36	2,8	870	375
300	68,1	2800	250	15,0	40	40	2,5	1015	425
350	76,3	3000	240	15,0	45	45	2,2	1160	475
400	83,6	3200	230	17,0	48	48	2,0	1285	525
450	90,0	3500	220	17,0	52	52	1,8	1430	575
500	95,4	3800	210	17,0	56	56	1,6	1570	625
550	100,0	4000	200	17,0	60	60	1,5	1715	675
600	103,6	4200	190	17,0	65	65	1,4	1860	725
650	106,3	4300	180	17,0	69	69	1,3	2000	775
700	108,1	4400	170	17,0	73	73	1,2	2145	825
750	109,0	4400	160	17,0	76	76	1,1	2290	875
800	109,0	4500	150	20,0	79	79	1,0	2395	925
900	106,3	4500	130	20,0	88	88	0,9	2685	1025
1000	100,0	4500	110	20,0	96	96	0,8	2970	1125

* At an ambient temperature of 30°C
** Relating to the max. permissible buffer force

Buffer Type PB 100

Dimensions and technical data



Rev. 02-16

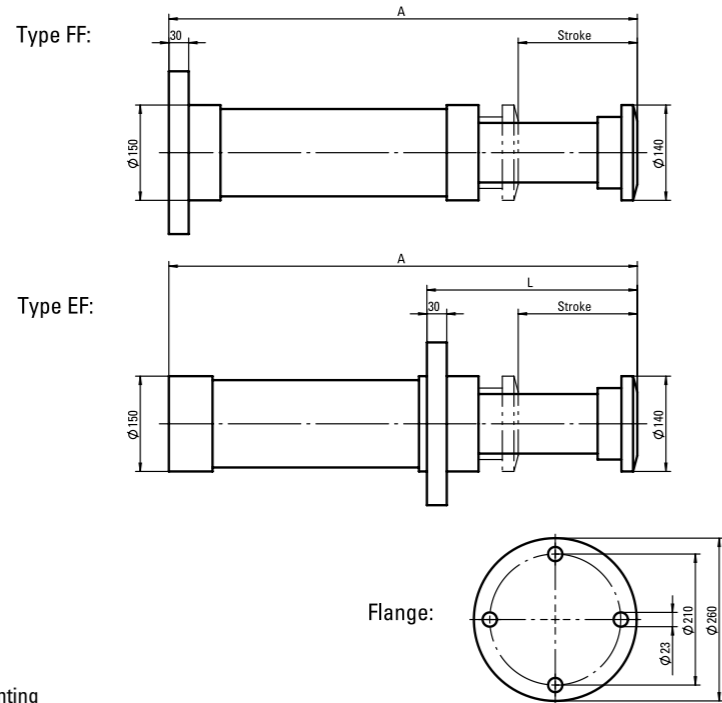

EF = front flange mounting
FF = foot (bottom) flange mounting

All dimensions in mm
Alterations reserved without notice

Stroke	Energy Stroke	* Energy h	Max. buffer force	Inward force	Weight	** Perm. angular deviation	** Perm. angular deviation	A	L
EF FF mm	EF FF kNm (kJ)	EF FF kNm (kJ)	EF FF kN	EF FF kN	EF FF kg	FF degree	EF degree	EF FF mm	EF mm
100	39	1700	430	20	42	5,0	6,0	460	255
150	59	2300	430	20	49	4,5	5,2	600	305
200	78	2750	430	25	57	4,0	4,5	735	355
250	98	3300	430	25	63	3,5	4,0	875	405
300	117	4000	430	25	70	3,0	3,5	1015	455
350	134	4800	420	25	77	2,2	3,0	1165	505
400	149	5500	410	30	84	1,8	2,5	1280	555
450	163	5850	400	30	90	1,6	2,2	1420	605
500	177	6150	390	30	95	1,4	2,0	1560	655
550	190	6450	380	30	100	1,2	1,9	1695	705
600	202	6700	370	30	106	1,0	1,8	1840	755
650	212	7000	360	30	112	-	1,7	1980	805
700	222	7300	350	30	117	-	1,6	2120	855
750	232	7600	340	30	123	-	1,5	2260	905
800	240	7800	330	30	129	-	1,4	2400	955
900	245	8000	300	30	144	-	1,2	2675	1055
1000	245	8200	270	30	160	-	1,0	2955	1155

* At an ambient temperature of 30°C
** Relating to the max. permissible buffer force

Buffer Type PB 125

Dimensions and technical data



Rev. 02-16

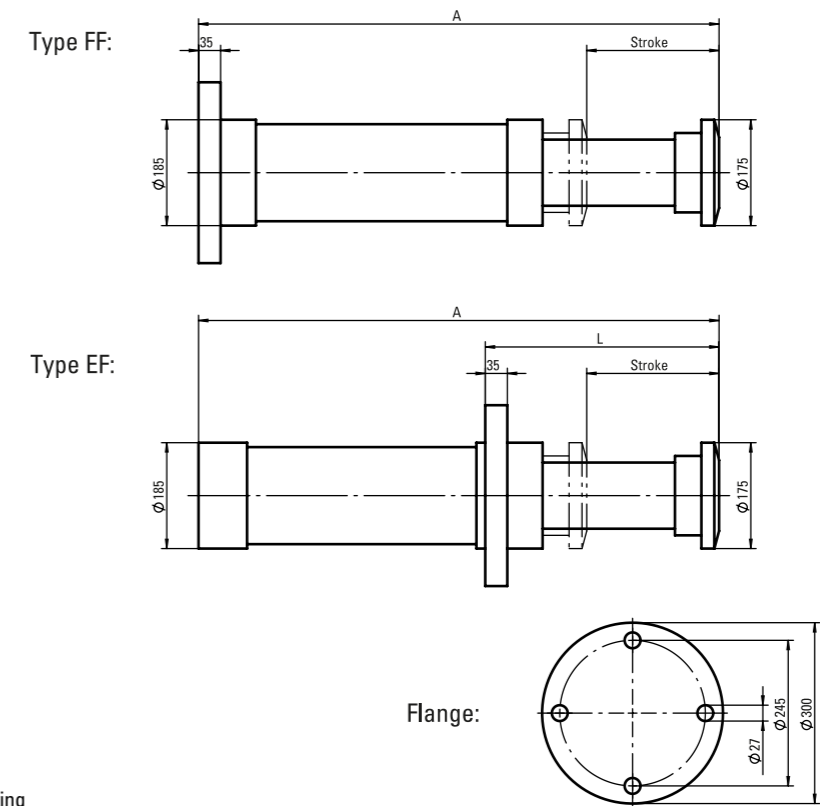

EF = front flange mounting
FF = foot (bottom) flange mounting

All dimensions in mm
Alterations reserved without notice

Stroke	Energy Stroke	* Energy h	Max. buffer force	Inward force	Weight	** Perm. angular deviation	** Perm. angular deviation	A	L
EF FF mm	EF FF kNm (kJ)	EF FF kNm (kJ)	EF FF kN	EF FF kN	EF FF kg	FF degree	EF degree	EF FF mm	EF mm
100	62	1800	680	55	60	5,5	6,5	470	251
150	93	2700	680	55	72	5,0	6,0	590	301
200	124	3500	680	55	83	4,4	5,4	730	351
250	155	4300	680	55	95	3,8	4,8	870	401
300	185	5000	680	60	108	3,0	4,0	1000	451
400	247	6500	680	60	133	2,2	3,2	1270	551
500	300	7300	660	60	148	1,5	2,8	1550	651
600	349	8000	640	70	162	1,0	2,4	1800	751
700	394	9000	620	80	182	-	2,2	2050	851
800	436	10000	600	90	198	-	2,0	2300	951
900	474	11000	580	90	215	-	1,8	2560	1051
1000	509	12000	560	90	230	-	1,6	2830	1151
1200	567	13000	520	95	260	-	1,2	3350	1351

* At an ambient temperature of 30°C
** Relating to the max. permissible buffer force

Buffer Type PB 160

Dimensions and technical data



Rev. 02-16

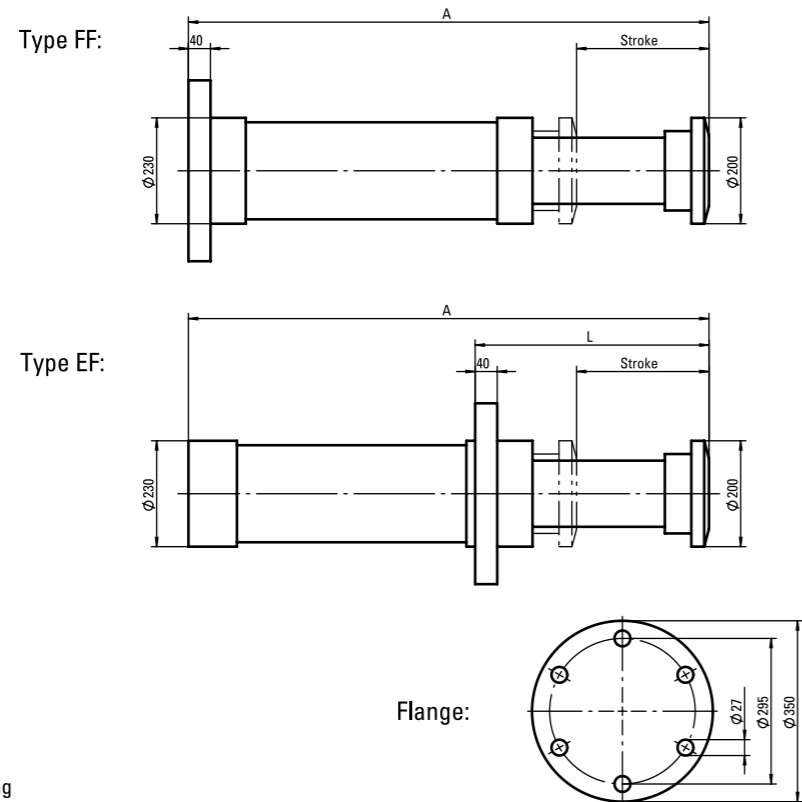

EF = front flange mounting
FF = foot (bottom) flange mounting

All dimensions in mm
Alterations reserved without notice

Stroke	Energy Stroke	* Energy h	Max. buffer force	Inward force	Weight	** Perm. angular deviation	** Perm. angular deviation	A	L
EF FF mm	EF FF kNm (kJ)	EF FF kNm (kJ)	EF FF kN	EF FF kN	EF FF kg	FF degree	EF degree	EF FF mm	EF mm
300	218	5800	800	85	175	2,4	4,0	1080	420
400	290	7000	800	85	206	2,2	3,5	1370	520
500	363	8300	800	85	237	1,8	3,2	1660	620
600	436	9500	800	85	268	1,3	3,0	1950	720
700	509	10500	800	85	299	-	2,8	2240	820
800	581	11500	800	85	330	-	2,6	2530	920
900	638	12000	780	90	361	-	2,4	2820	1020
1000	690	13500	760	90	391	-	2,2	3100	1120
1100	740	14200	740	120	407	-	2,0	3300	1220
1200	785	15000	720	160	427	-	1,8	3500	1320
1300	827	15300	700	160	454	-	1,6	3780	1420
1400	865	15700	680	160	481	-	1,4	4050	1520
1500	900	16000	660	160	511	-	1,2	4330	1620
1600	930	17000	640	160	539	-	1,0	4600	1720

* At an ambient temperature of 30°C
** Relating to the max. permissible buffer force

Notes



H



6th edition

PINTSCH BUBENZER GmbH

Friedrichshuettenstr. 1
D-57548 Kirchen-Wehbach
Phone +49 27 41/94 88-0

Huenxer Str. 149
D-46537 Dinslaken
Phone +49 20 64/602-0

www.pintschbubenzler.com