

DISC BRAKE – MODEL SKD 4x100

PRESSURE APPLIED, SPRING RELEASED DISC BRAKE

Dellner Brakes model SKD 4x100 disc brake is a direct acting, hydraulic pressure applied, spring released unit. The braking force achieved is directly proportional to the applied pressure.

The brake consists of two symmetrical halves, produced of steel, between which the support structure with variable thicknesses can be mounted to accommodate any brake disc thickness.

Each brake half has two cylindrical guide pins that transmit the tangential braking force from the brake pads to the brake housing and mounting stand. As a result, the brake pistons are not subject to any radial forces which contributes to longer brake life.

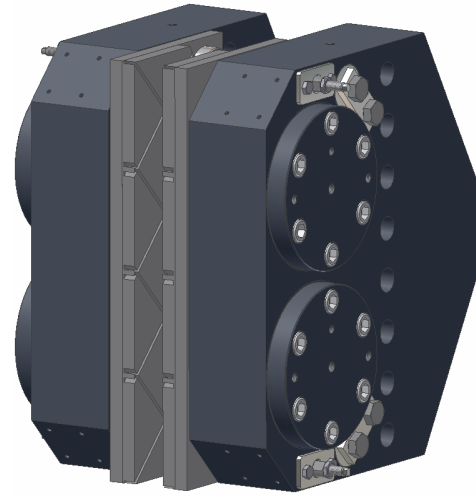

Two springs on each brake half retract the brake pads from the disc when pressure is released. Brake pad wear is automatically compensated for with increased piston stroke.

Braking force ¹⁾		Max hydraulic pressure [bar]	Friction area per brake [cm ²]	Max. working oil volume per brake ²⁾ [cm ³]	Piston area per brake half [cm ²]	Weight [kg]
F ₁ [N/bar]	F _{max} [N]					
1294	258800	200	1342	471	157	260

- 1) Calculated with an average frictional coefficient $\mu=0,42$. Consideration has not been taken for external factors.
- 2) Oil volume required to engage the brake with fully worn friction pads.

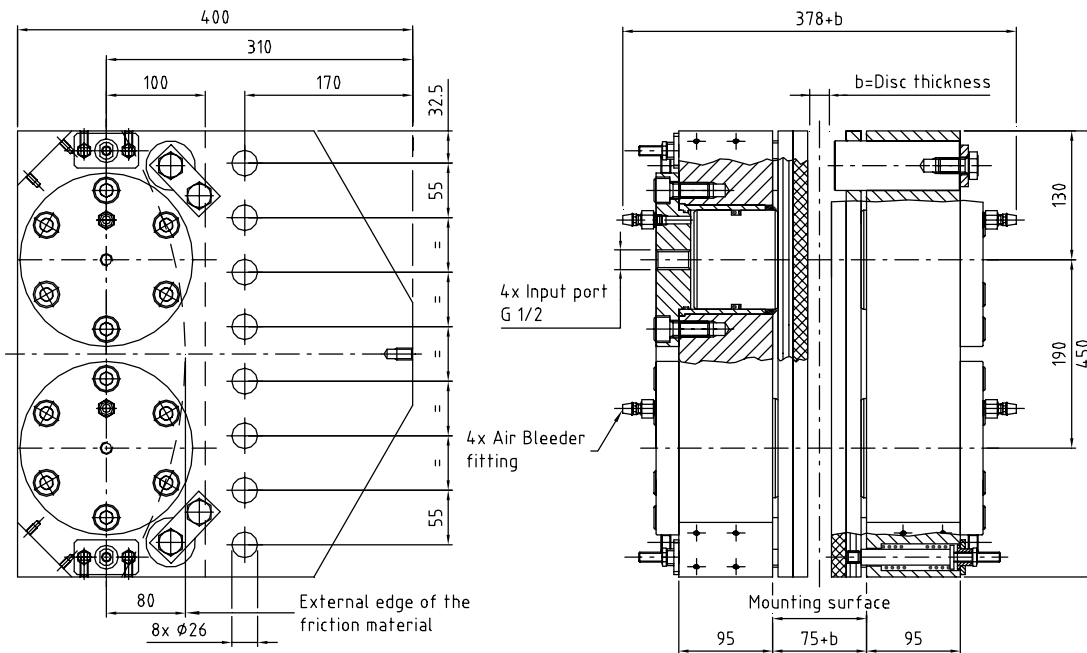

Dellner Brakes AB reserves the rights to modification without special notice.



Torque table

SKD 4x100

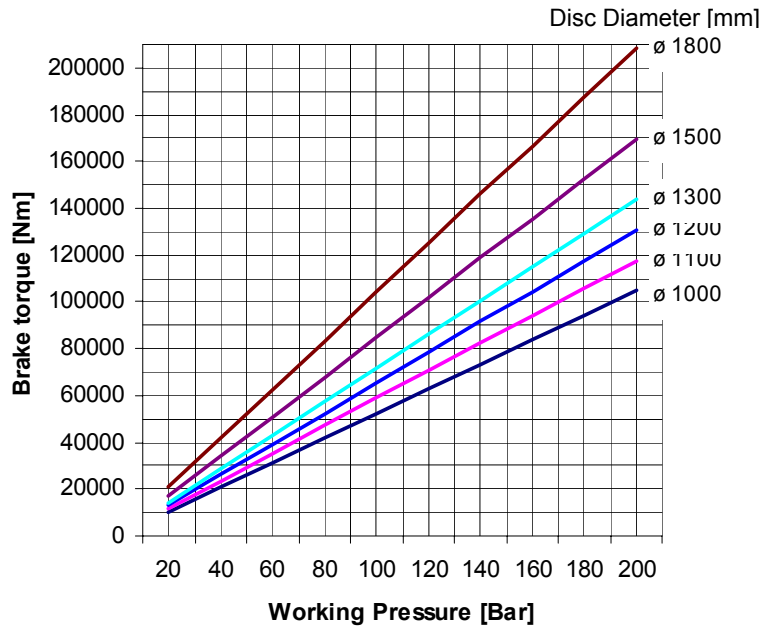

The braking torque is calculated from the following formula:

$$M_{brake} = \frac{q \times F_1 \times p \times (D_s - H)}{2}$$

q = number of brakes

F₁ = braking force according to the table on page 1 [N]

p = pressure [bar]

D_s = brake disc diameter [m]

H = brake pad height [m] (SKD 4x100: 0,19)

Options

- ✚ Proximity or mechanical switches for on/off or pad wear indication.

Suitable applications

Dellner Brakes model SKD 4x100 is suitable wherever service, stopping, holding and tensioning brakes are needed, for example in the following types of applications:

- ✚ Propulsion propeller shafts
- ✚ Wind mills
- ✚ Test rigs
- ✚ Metal forming
- ✚ Water turbines
- ✚ Heavy duty tensioning applications