

**FRENI ELETTRMAGNETICI
MONODISCO
Serie DFM-3**

**SINGLE PLATE
ELECTROMAGNETIC BRAKES
Model DFM-3**

PRESTAZIONI (24 VCC) • PERFORMANCES (24VDC)

tipo size	coppia torque (Nm)	potenza power (W)	giri/min rpm	tempo inserzione engagement time (ms)	tempo disinserzione disengagement time (ms)	peso weight (kg)
DFM 065-3	3,6	10	10.000	35	6	0,28
DFM 080-3	7,5	11,5	8.000	35	10	0,32
DFM 100-3	15	16	6.000	40	20	0,59
DFM 125-3	30	21	5.000	60	30	1,11
DFM 150-3	60	28	4.000	80	45	2
DFM 190-3	120	38	3.000	100	60	3,5
DFM 230-3	240	45	3.000	115	70	7,1
DFM 290-3	480	70	2.000	130	80	12,7

DIMENSIONI (mm) • DIMENSIONS (mm)

tipo - size	A	B	C H8	D h8	E	F	G	L	N	Q	R	S	V max
DFM 065-3	54	23,5	26	65	4x3,4	2	58	29,7	-	24	12	0,2	15
DFM 080-3	63	18	35	80	4x4,5	2	72	25,5	3,5	33	15	0,2	17
DFM 100-3	80	20	42	100	4x5,5	2,5	90	28,5	4,3	32	20	0,2	22
DFM 125-3	100	22	52	125	4x6,6	3	112	32,9	5	42	25	0,2	30
DFM 150-3	125	24	62	150	4x6,6	3,5	137	37	5,5	49	30	0,3	35
DFM 190-3	160	26	80	190	4x9	4	175	42	6	65	38	0,3	45
DFM 230-3	200	30	100	230	4x9	5	215	50,4	7	83	48	0,5	60
DFM 290-3	250	35	125	290	4x11	6	270	58,9	8	105	55	0,5	70

DENOMINAZIONE PARTI • PARTS NAME

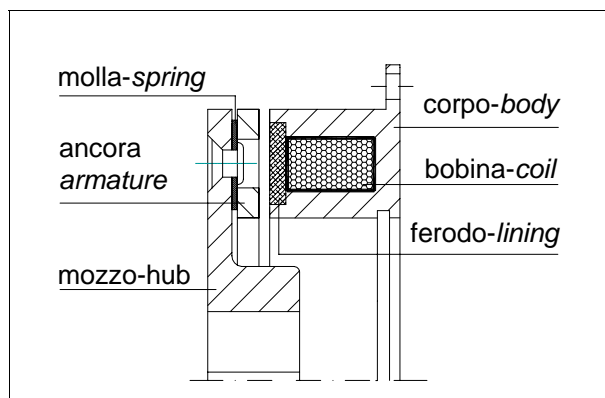

ESEMPIO DI MONTAGGIO • MOUNTING EXAMPLE

