

**FRIZIONI
ELETTROMAGNETICHE
MONODISCO
Serie DSM - 2**

**SINGLE PLATE
ELECTROMAGNETIC
CLUTCHES
Model DSM - 2**

PRESTAZIONI (24 VCC) • PERFORMANCES (24VDC)

tipo size	coppia torque (Nm)	potenza power (W)	giri/min rpm	tempo inserzione engagement time (ms)	tempo disinserzione disengagement time (ms)	peso weight (kg)
DSM 039-2	0,6	6	10.000	15	3	0,07
DSM 045-2	0,9	6	10.000	20	4	0,12
DSM 054-2	1,8	8	10.000	25	5	0,20
DSM 065-2	3,6	10	10.000	35	6	0,32
DSM 080-2	7,5	15	8.000	35	10	0,53
DSM 100-2	15	20	6.000	40	20	0,96
DSM 125-2	30	28	5.000	60	30	1,84
DSM 150-2	60	35	4.000	80	45	3,24
DSM 190-2	120	50	3.000	100	60	5,79
DSM 230-2	240	68	3.000	115	70	11,4
DSM 290-2	480	85	2.000	130	80	20,4

DIMENSIONI (mm) • DIMENSIONS (mm)

tipo-size	A	B	C H8	D h9	E	F	G	H	I	L	M	N max	P	R max	S	T
DSM 039-2	8	14	11	39	31	31	-	33,5	1,5	4x3,4	13	8	26,35	6	0,1	16
DSM 045-2	10	17	13	45	34	34	-	38	2	4x3,4	15	8	31,55	6	0,15	19
DSM 054-2	12	19,3	19	54	43	43	-	47	2	4x3,4	17	10	37,4	10	0,15	22,3
DSM 065-2	12	20,5	26	65	54	54	-	58	2	4x3,4	24	15	38,7	15	0,2	23,5
DSM 080-2	15	22	35	80	63	68	3,5	72	2	4x5	27	17	43	17	0,2	24
DSM 100-2	20	24	42	100	80	85,5	4,3	90	2,5	4x5,5	32	22	51	25	0,2	26,5
DSM 125-2	25	27	52	125	100	107	5	112	3	4x6,6	42	30	60,9	30	0,2	30
DSM 150-2	30	30	62	150	125	134,3	5,5	137	3,5	4x6,6	49	35	70,5	40	0,3	33,5
DSM 190-2	38	34	80	190	160	170	6	175	4	4x9	65	45	84,5	50	0,3	37,5
DSM 230-2	48	40	100	230	200	214,3	7	215	5	4x9	83	60	103,4	60	0,5	44
DSM 290-2	55	47	125	290	250	266,5	8	270	6	4x11	105	70	118,9	80	0,5	51

DENOMINAZIONE ELEMENTI - PARTS NAME

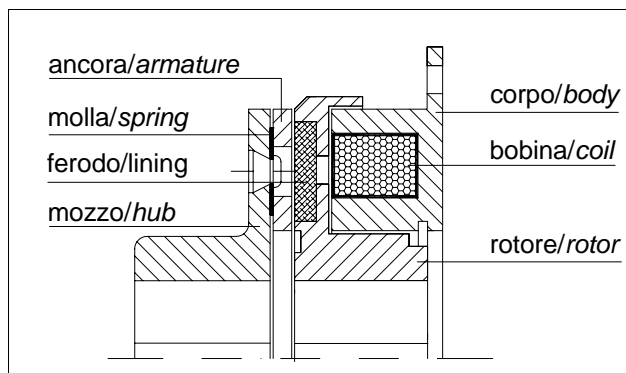

ESEMPIO DI MONTAGGIO - MOUNTING EXAMPLE

