

**FRENO A PINZA
PNEUMATICO NEGATIVO
Tipo SPO N10**

**PNEUMATIC CALIPER
BRAKE SPRING APPLIED
Type SPO N10**

PRESTAZIONI (5 bar) • PERFORMANCES (5 bar)

tipo - size	forza F – force F (N)	Ø disco – disc Ø (mm)	coppia M - torque M (Nm)	V aria - air V (dm ³)	peso - weight (kg)
SPO N10	2550	1500 ÷ 300	$M = F \times (\text{Ø}/2 - 0,025)$	0,07	4

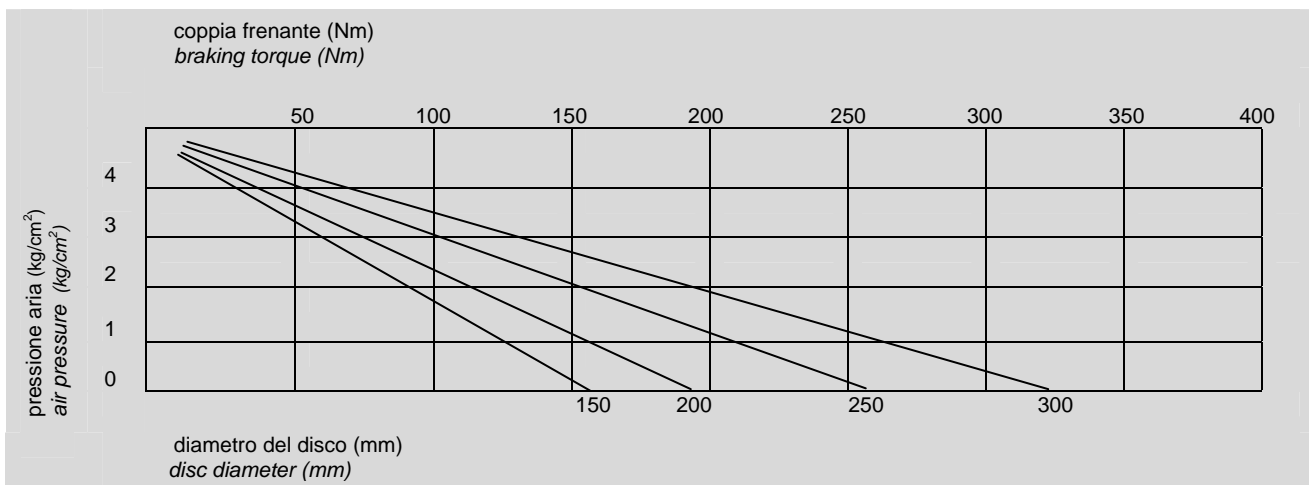

NOME PARTICOLARI • PARTS NAME

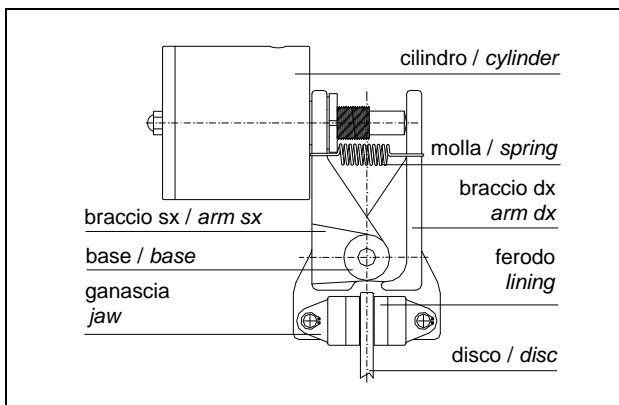

ESEMPIO MONTAGGIO • MOUNTING EXAMPLE

