

**FRENO A PINZA PNEUMATICO  
POSITIVO  
Tipo SPG 020**

**PNEUMATIC CALIPER BRAKE  
Type SPG 020**

**PRESTAZIONI ( 7 bar ) • PERFORMANCES ( 7 bar )**

| tipo - size | forza F – force F (N) | Ø disco – disc Ø (mm) | coppia M – torque M (Nm)     | V aria - air V (dm <sup>3</sup> ) | peso - weight (kg) |
|-------------|-----------------------|-----------------------|------------------------------|-----------------------------------|--------------------|
| SPG 020     | 8050                  | 250 ÷ 915             | $M = F \times ( D/2 - 0,03)$ | 0,25                              | 11,3               |

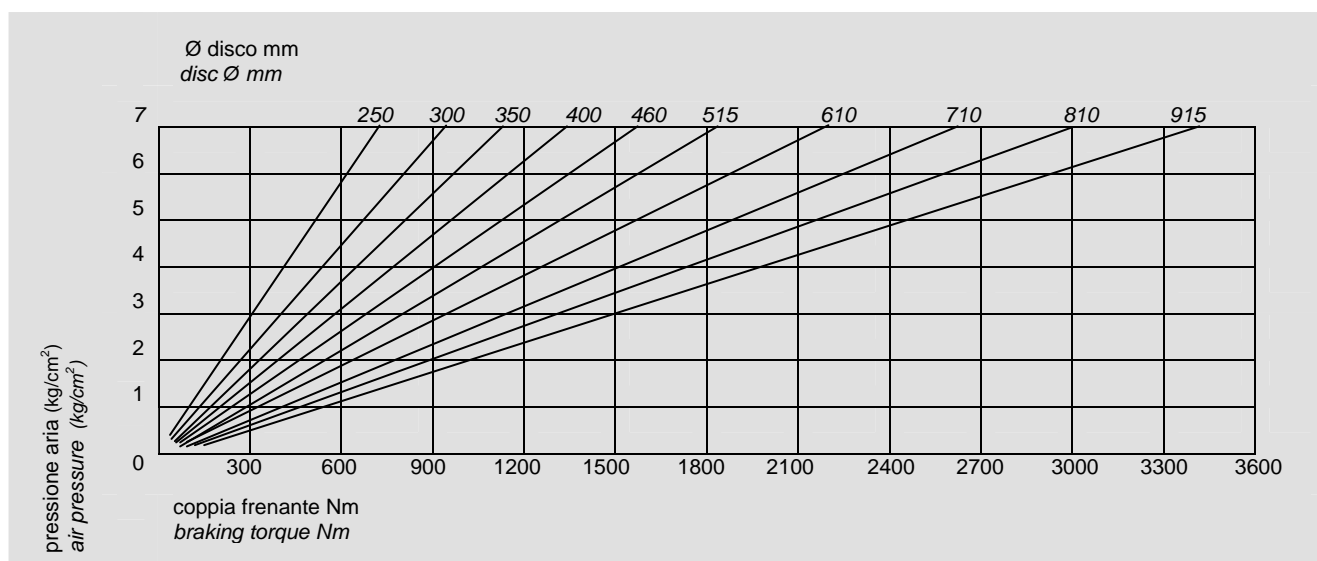

**NOME PARTICOLARI • PARTS NAME**

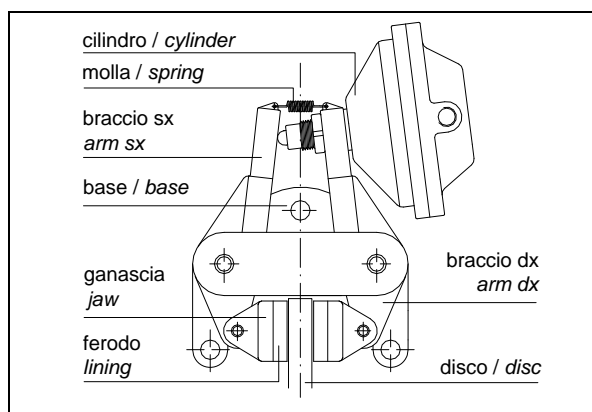

**ESEMPIO MONTAGGIO • MOUNTING EXAMPLE**

