

**FRENO A PINZA PNEUMATICO
NEGATIVO
Tipo SPH N30**

**PNEUMATIC CALIPER BRAKE
SPRING APPLIED
Type SPH N30**

PRESTAZIONI (5 bar) • PERFORMANCES (5 bar)

tipo - size	forza F – force F (N)	Ø disco – disc Ø (mm)	coppia M - torque M (Nm)	V aria - air V (dm ³)	peso - weight (kg)
SPH N30	11000	300 ÷ 915	$M = F \times (\frac{\text{Ø}}{2} - 0,033)$	0,7	18,8

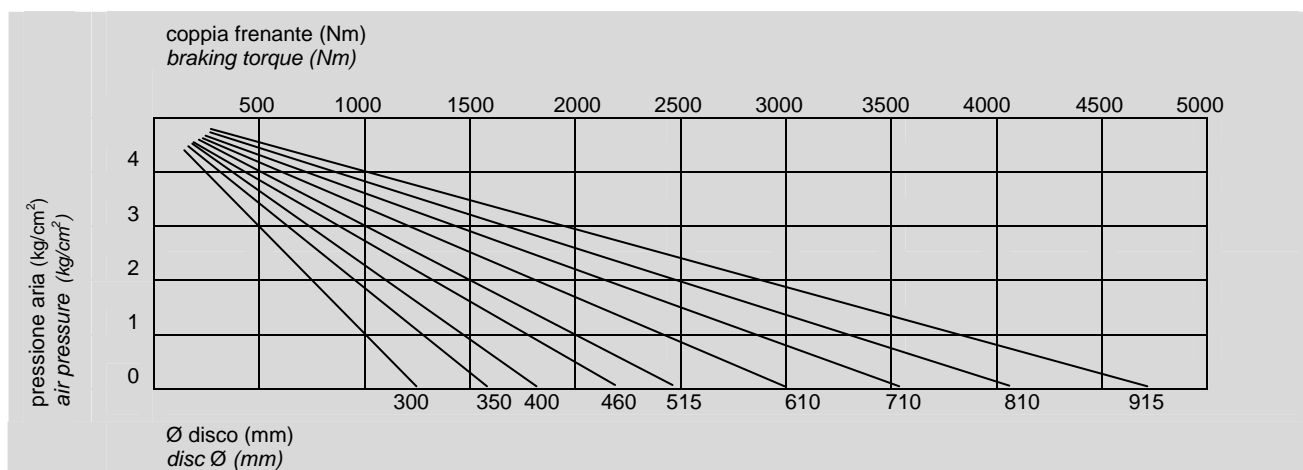

NOME PARTICOLARI • PARTS NAME

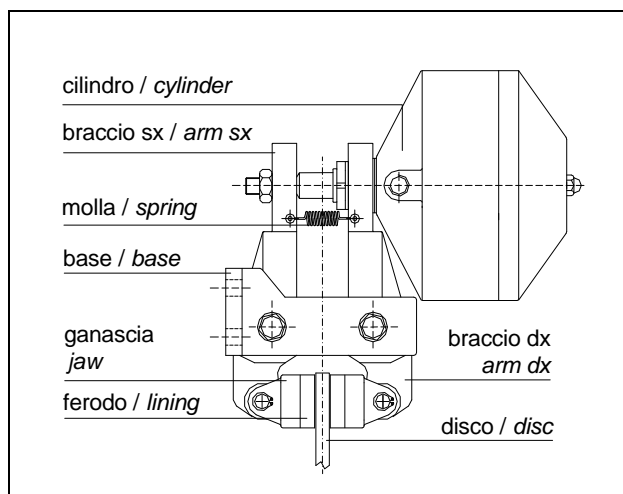

ESEMPIO MONTAGGIO • MOUNTING EXAMPLE

