

**FRENO A PINZA
PNEUMATICO NEGATIVO
Tipo SPL N30**

**PNEUMATIC CALIPER
BRAKE SPRING APPLIED
Type SPL N30**

PRESTAZIONI (5 bar) • PERFORMANCES (5 bar)

tipo - size	forza F – force F (N)	Ø disco – disc Ø (mm)	coppia M - torque M (Nm)	V aria - air V (dm ³)	peso - weight (kg)
SPL N30	11000	515 ÷ 915	$M = F \times (\frac{\varnothing}{2} - 0,062)$	0,7	24,3

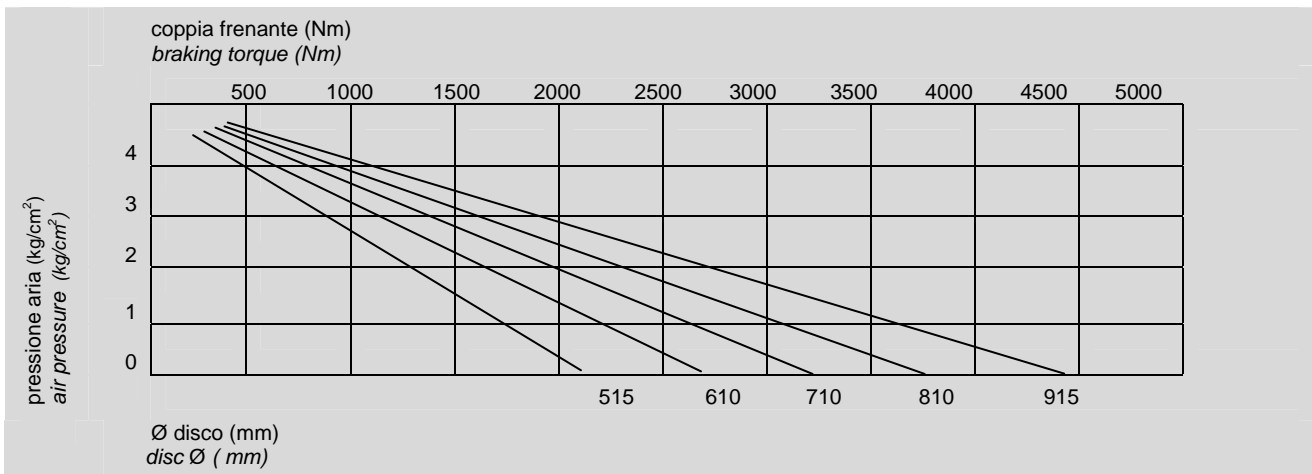

NOME PARTICOLARI • PARTS NAME

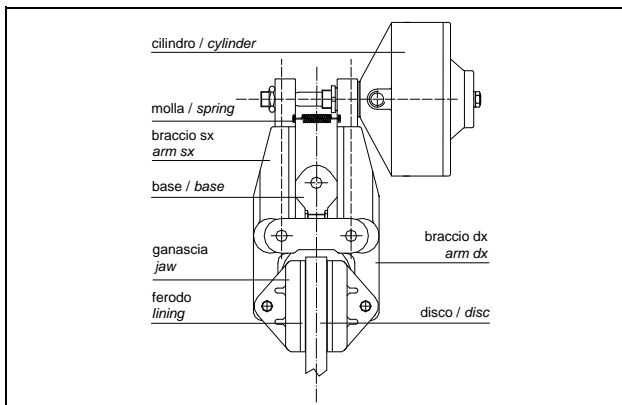

ESEMPIO MONTAGGIO • MOUNTING EXAMPLE

