

**FRENO A PINZA
PNEUMATICO POSITIVO
Tipo SPO 005**

**PNEUMATIC CALIPER
BRAKE
Type SPO 005**

PRESTAZIONI (7bar) • PERFORMANCES (7 bar)

tipo - size	forza N – force N (N)	Ø disco – disco Ø (mm)	coppia M – torque M (Nm)	V aria - air V (dm ³)	peso - weight (kg)
SPO 005	1579	150 ÷ 300	$M = N \times (\frac{\varnothing}{2} - 0,025)$	0,007	3,1

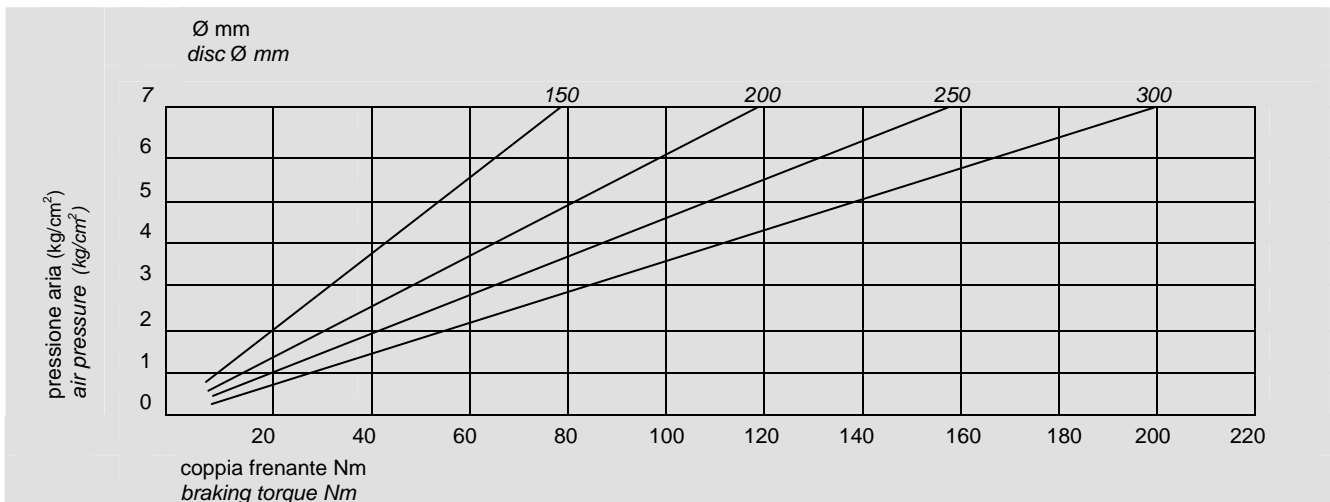

NOME PARTICOLARI • PARTS NAME

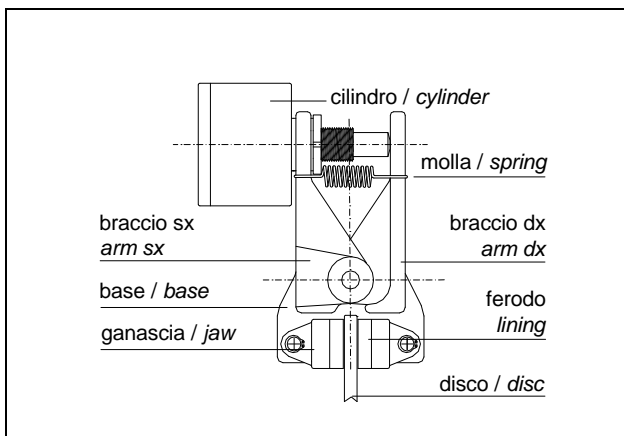

ESEMPIO MONTAGGIO • MOUNTING EXAMPLE

