

**FRENO A PINZA IDRAULICO
POSITIVO
Tipo SYG 010**

**HYDRAULIC CALIPER BRAKE
Type SYG 010**

PRESTAZIONI (100 bar) • PERFORMANCES (100 bar)

tipo - size	forza F – force F (N)	Ø disco – disc Ø (mm)	coppia M – torque M (Nm)	V olio - oil V (dm ³)	peso - weight (kg)
SYG 010	13000	300 ÷ 915	$M = F \times (\frac{\text{Ø}}{2} - 0,033)$	0,03	10,8

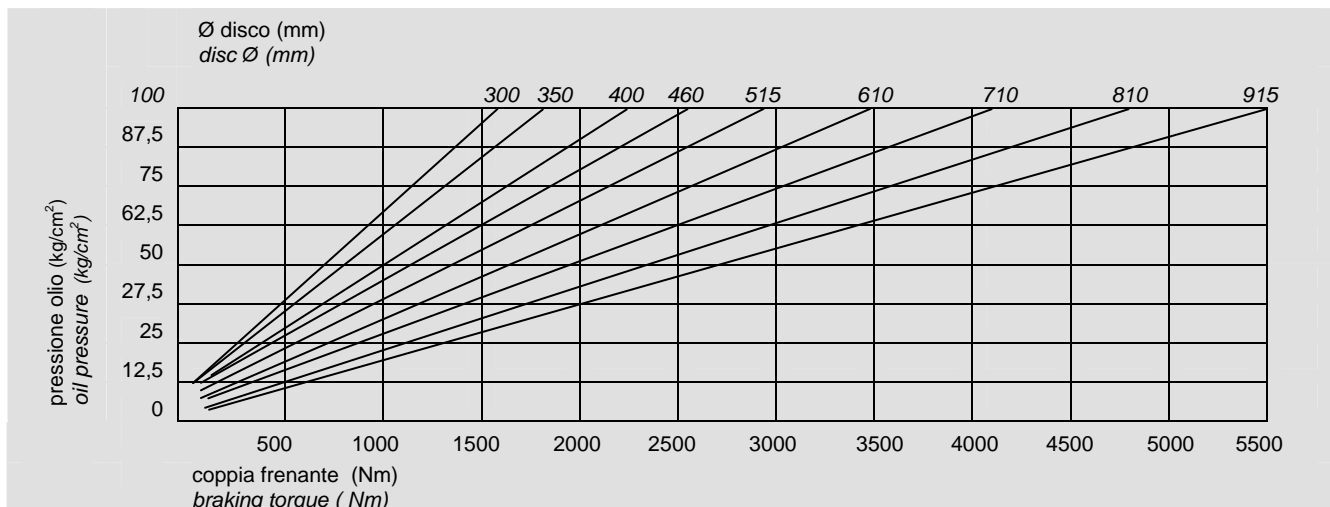

NOME PARTICOLARI • PARTS NAME

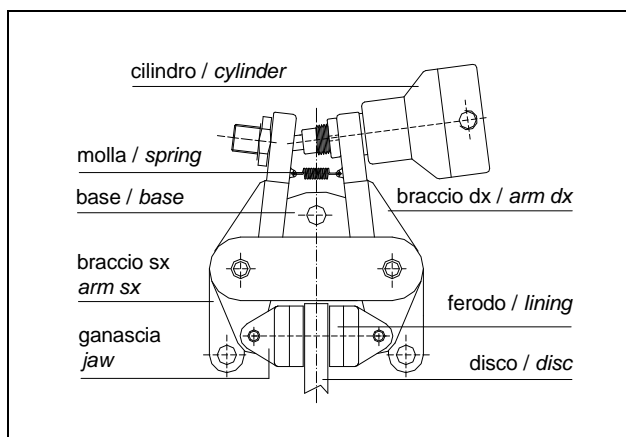

ESEMPIO MONTAGGIO • MOUNTING EXAMPLE

