

**FRENO A PINZA IDRAULICO
POSITIVO
Tipo SYL 020**

**HYDRAULIC CALIPER BRAKE
Type SYL 020**

PRESTAZIONI (100 bar) • PERFORMANCES (100 bar)

tipo - size	forza F – force F (N)	Ø disco – disc Ø (mm)	coppia M – torque M (Nm)	V olio - oil V (dm ³)	peso - weight (kg)
SYL 020	13000	515 ÷ 915	$M = F \times (\text{Ø}/2 - 0,062)$	0,03	16,8

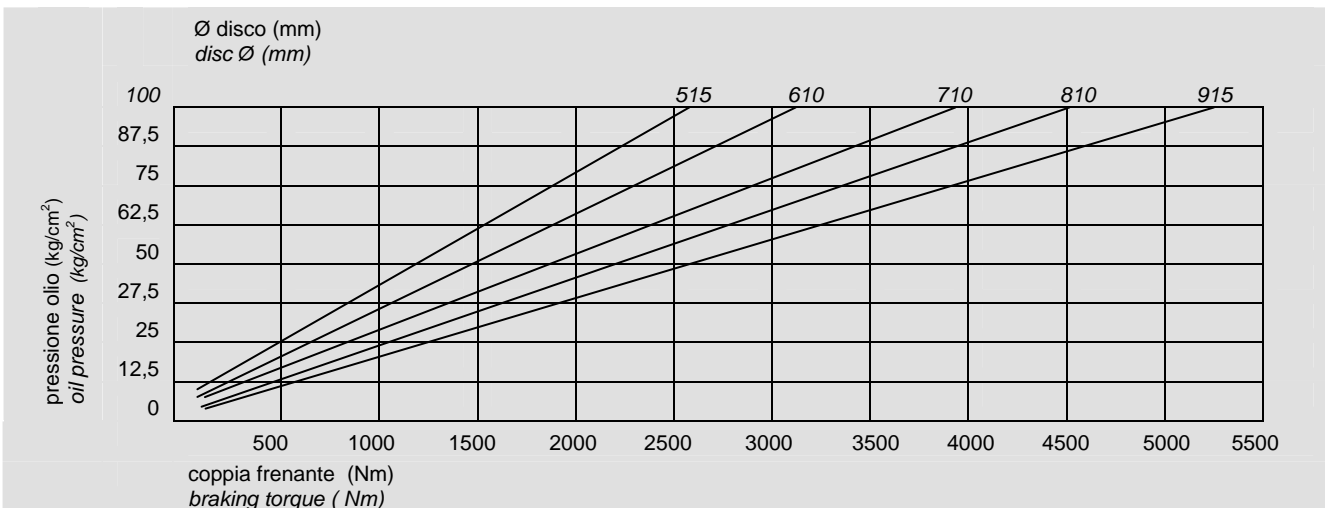

NOME PARTICOLARI • PARTS NAME

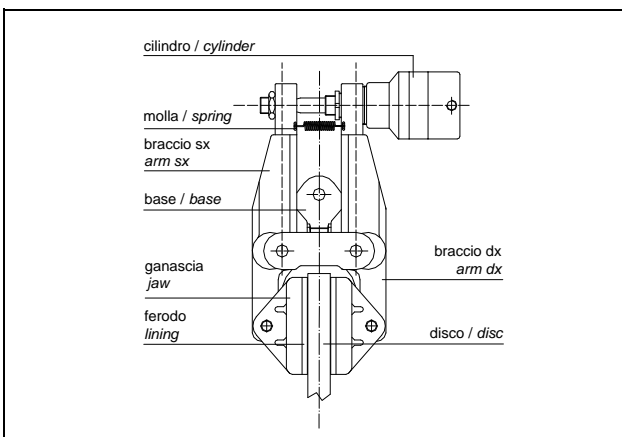

ESEMPIO MONTAGGIO • MOUNTING EXAMPLE

