

**FRENO A PINZA IDRAULICO
NEGATIVO
Tipo SYL N10**

**HYDRAULIC CALIPER BRAKE
SPRING APPLIED
Type SYL N10**

PRESTAZIONI (50 bar) • PERFORMANCES (50 bar)

tipo - size	forza F – force F (N)	Ø disco – disc Ø (mm)	coppia M - torque M (Nm)	V olio - oil V (dm ³)	peso - weight (kg)
SYL N10	11000	515 ÷ 915	$M = F \times (\varnothing/2 - 0,062)$	0,09	21,8

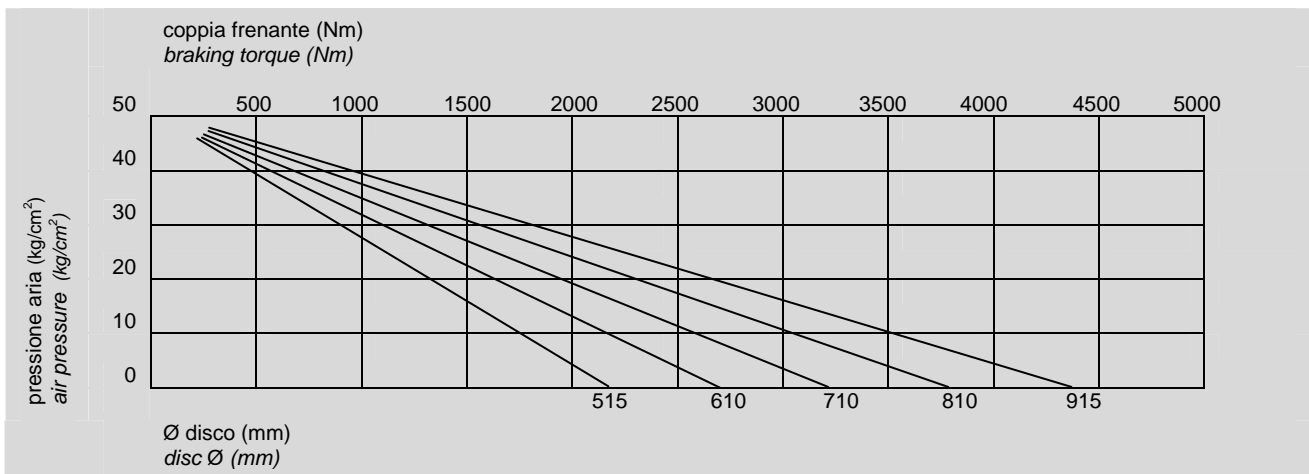

NOME PARTICOLARI • PARTS NAME

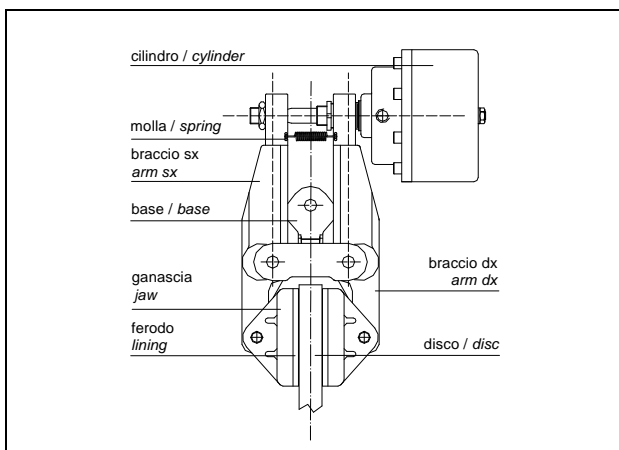

ESEMPIO MONTAGGIO • MOUNTING EXAMPLE

