

**FRENO A PINZA MANUALE  
Tipo SMP 010**

**HAND CALIPER BRAKE  
Type SMP 010**

**PRESTAZIONI • PERFORMANCES**

tipo - size	Forza F – force F (N)	Ø disco – disc Ø (mm)	coppia - torque (Nm)	peso - weight (kg)
SMP 010	1130	200 ÷ 610	$M = F \times (\frac{\varnothing}{2} - 0,032)$	5,4

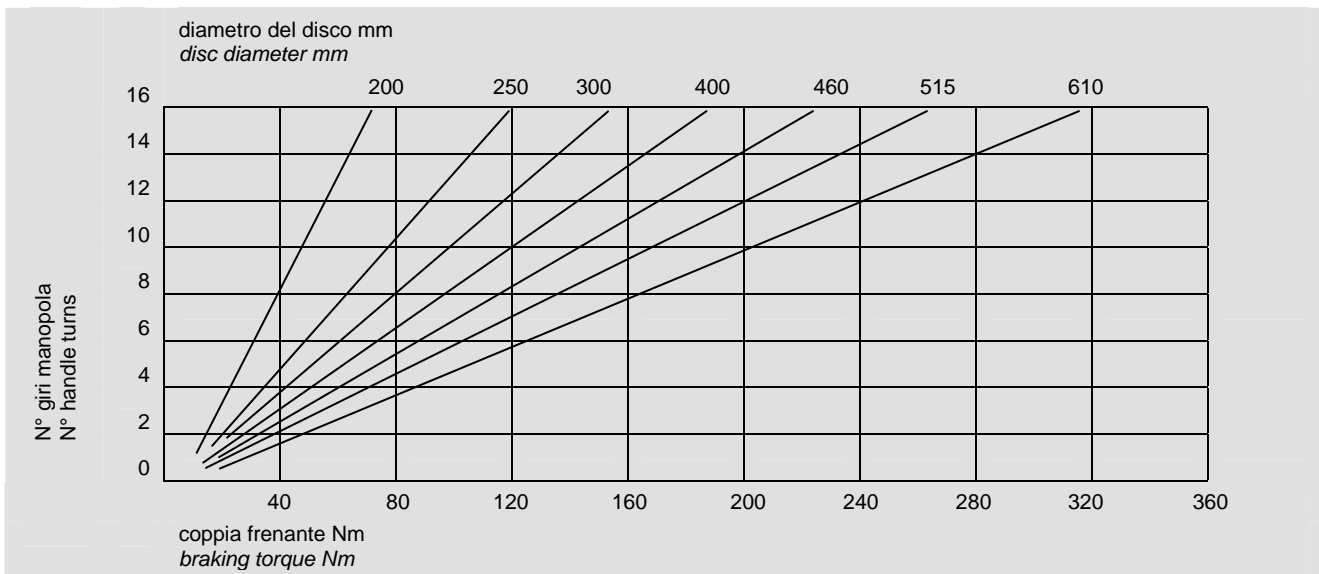

**NOME PARTICOLARI • PARTS NAME**

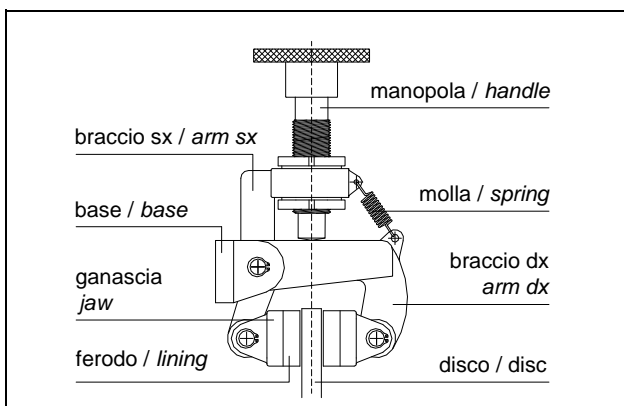

**ESEMPIO MONTAGGIO • MOUNTING EXAMPLE**

