

**FRENO A PINZA MANUALE
Tipo SMR 060**

**HAND CALIPER BRAKE
Type SMR 060**

PRESTAZIONI • PERFORMANCES

tipo - size	forza F – force F (N)	Ø disc – disc Ø (mm)	coppia M – torque M (Nm)	peso - weight (kg)
SMR 060	40000	610 ÷ 1370	$M = F \times (\frac{\text{Ø}}{2} - 0,065)$	66

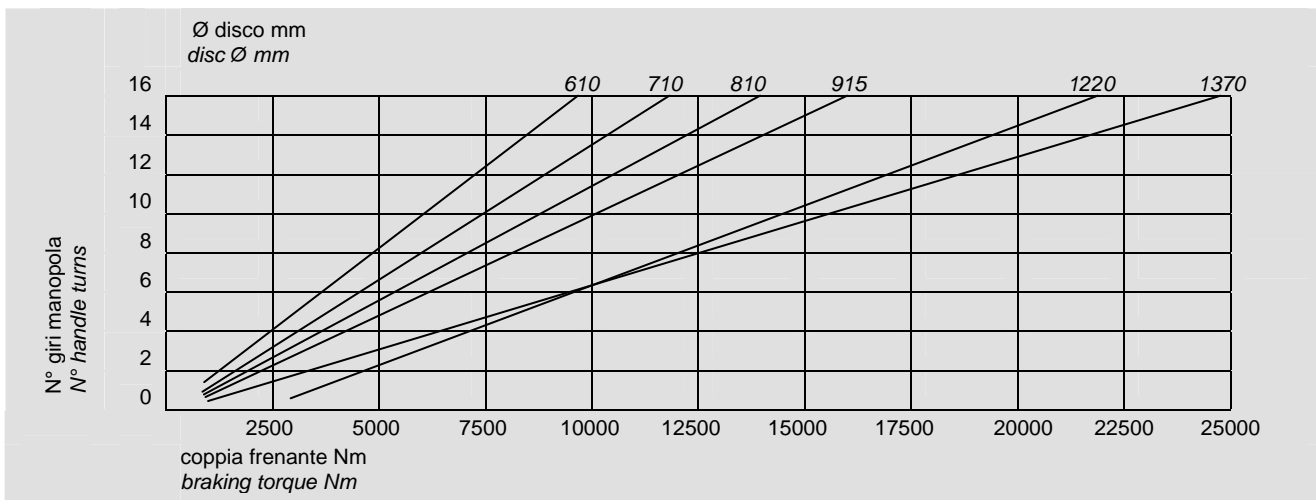

NOME PARTICOLARI • PARTS NAME

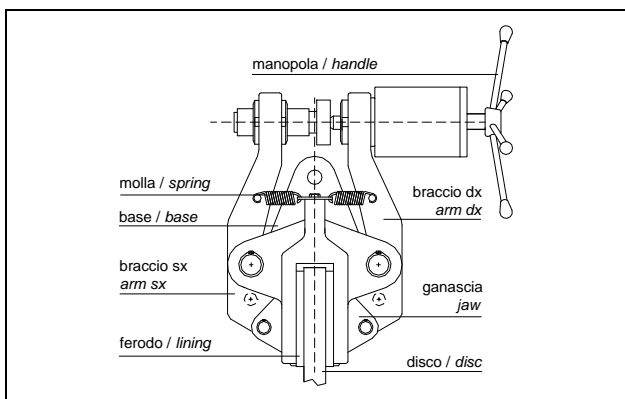

ESEMPIO MONTAGGIO • MOUNTING EXAMPLE

