

# Sure-Flex Plus® Elastomeric Couplings (Metric)



# Sure-Flex Plus® couplings are a TB Wood's original!

Sure-Flex Plus couplings utilize EPDM, Neoprene, Hytrel™ and Urethane flexible elastomer sleeves to transmit torque and accommodate shaft misalignment. Sure-Flex Plus couplings have exceptional torsional flexibility, with the 4-way flexing action absorbing virtually all types of shock, vibration, misalignment and end float. Sure-Flex Plus couplings are an excellent choice when low cost, high flexibility, low vibration and easy installation are important.



## Easy, Quick Installation

Sure-Flex Plus can be installed quickly and easily, thanks to its simple design with no bolts, gaskets, covers or seals. Alignment can be checked on the precision machined flanges using only a straightedge and calipers. No special tools are needed for installation, alignment or removal.

## No Lubrication, Trouble-Free Operation

The teeth of the sleeve lock into the teeth of the flanges without clamps or screws, tightening under torque to provide smooth transmission of power. Couplings are not affected by abrasives, dirt or moisture, eliminating the need for lubrication or maintenance and providing clean, dependable, quiet performance.



## Sure-Flex Plus couplings last over 3X longer

Fatigue Test to Failure results reveal that Sure-Flex Plus sleeves last over three times as long as the nearest competitive sleeve. See brochure P-7819-TBW.

## Features (Metric)

- Up to 8.20 kNm; 72,480 in.lbs.
- Quick and easy installation
- Spacer, bushed hub and clamping hub designs in stock
- Flexible design accommodates misalignment and protects equipment
- 7° to 21° torsional wind up
- Needs no lubrication, no maintenance

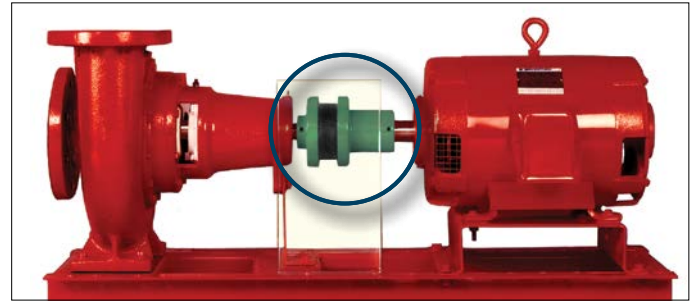

## Applications

Sure-Flex Plus couplings can be found hard at work in many industries such as power generation and material handling. These couplings are ideal for a wide variety of applications including:

- Pumps
- Fans/Blowers
- Compressors
- Mixers
- Electric Motors
- Conveyors



## New! Sure-Flex® PLUS+

For over 50 years, TB Wood's has led the coupling industry with the original TB Wood's Sure-Flex design. And we haven't stopped innovating: this industry favorite just got even better. Our new Sure-Flex Plus EPDM and Neoprene sleeves are best-in-class for coupling performance and value. Here's why:

### High Torque Rating

#### • 30% Increased Torque Rating

Sure-Flex Plus sleeves provide longer service life in demanding applications, reducing required maintenance and associated replacement cost.

### Longer Life

#### • Sure-Flex Plus Lasts Over 3X Longer than the Competition

Extensive testing shows our sleeves outlast the imitators. More uptime means less costly downtime.

### Better Value

#### • Save Money Using a Smaller Coupling

Over 50% of common applications can now use a smaller coupling, lowering the cost of both coupling purchase and sleeve replacement.

### Interchangeable

#### • Retrofits to Existing Flanges

No need to replace the full coupling – the Sure-Flex Plus sleeve design is 100% compatible with the current industry standard created by TB Wood's over 50 years ago.

**Sure-Flex Plus 4-Way flexing action  
absorbs all types of shock, vibration and  
misalignment**



**Torsional**

Sure-Flex Plus coupling sleeves have an exceptional ability to absorb torsional shock and dampen torsional vibrations. The EPDM and Neoprene sleeves wind up approximately 21° torsionally at their rated torque. Hytrel sleeves wind up approximately 7°.



**Angular**

The unique design of the Sure-Flex Plus coupling's teeth allows for the absorption of angular misalignment without wear. Refer to page 17 for misalignment limits. Angular alignment can be achieved using only a scale and calipers.



**Parallel**

Parallel misalignment is absorbed without wear or appreciable energy loss. The lateral flexibility of the coupling sleeve minimizes radial bearing loads normally associated with parallel misalignment. This feature also allows for easier installation by the use of components bored for slip fits without fretting corrosion occurring at the shaft. Refer to page 17 for parallel misalignment limits. Only a straight-edge and feeler gage are required for parallel alignment.



**Axial**

Sure-Flex Plus couplings may be used in applications with limited axial shaft movements. The axial compressibility of the EPDM and Neoprene sleeves allows for shaft end-float without the absolute transfer of thrust loads.

**Table of Contents**

Selection Guide	3-7
Components	3
Sleeve Selection	4
Assembly Dimensions	5
Load/Service Factor	6
Coupling Ratings	7
Type S BTS Couplings	8-9
Type J BTS Couplings	10
Type B QD Bushed Couplings	11
Type SC BTS Spacer Couplings	12-15
Type C Clamp Hub Couplings	16
Installation Instructions	17

**Metric Version Catalog**

For Imperial information  
see Catalog P-1690-TBW

**Sure-Flex Plus Selection Guide**

Use the Coupling Selector Program on [www.TBWoods.com/Select](http://www.TBWoods.com/Select)  
Or follow these steps:

**Sure-Flex Plus couplings are selected as component parts.**

1. Determine SLEEVE material and type.  
Refer to pages 4 & 5
2. Determine coupling SIZE.  
Refer to pages 6 & 7
3. Determine FLANGES to be used.  
Refer to pages 8 thru 16

**Specify coupling components.**

- Example #1 - Close coupled  
Size 6, Type S flange w 35 mm bore  
Size 6, Type S flange w 25 mm bore  
Size 6, Split EPDM sleeve
- Example #2 - 5" Between shaft spacer  
Size 9, Type SC flange for #11 hub  
Size 9, Type SC flange for #9 hub  
Size 11 Hub w 2-3/8" bore  
Size 9 Short hub w 1-1/8" bore  
Size 9 Solid Hytrel sleeve

Product Number	Product Description
6S35MM	6S x 35 mm
6S25MM	6S x 25 mm
6JS	6JES
9SC5011	9SC50-11
9SC50	9SC50
11SCH238	11SCH x 2-3/8
9SCHS118	9SCHS x 1-1/8
9H	9H

# Selection Guide

## Sleeve Selection

Sure-Flex Plus Sleeves are available in four materials or compounds and various shape configurations.

**New Sure-Flex Plus EPDM and Neoprene sleeves have 30% higher torque capacity. See page 2 for details.**

	EPDM	Neoprene	Hytrel	Urethane
Constructions Available				
1 pc, unsplit	JE	JN	H	U
1 pc, split	JES	JNS	—	—
2 piece, E/N with ring	E	N	HS	—
Typical Use	General Purpose	Oil Resistant Non-Flame	General Purpose	Stiffness
Relative Rating	1X	1X	3X	3X
Wind-Up Angular	21°	21°	7°	3°
Misalign	1°	1°	1/4°	1/4°
Temperature (C)				
maximum	+135° C	+93° C	+121° C	+93° C
minimum	-34° C	-18° C	-54° C	-62° C

## Sure-Flex Plus Sleeves

Part Number	Description	Part Number	Description	Part Number	Description
3J	3JE EPDM	4	4E EPDM	6H	6H Hytrel
4J	4JE EPDM	5	5E EPDM	7H	7H Hytrel
5J	5JE EPDM	6	6E EPDM	8H	8H Hytrel
6J	6JE EPDM	7	7E EPDM	9H	9H Hytrel
7J	7JE EPDM	8	8E EPDM	10H	10H Hytrel
8J	8JE EPDM	9	9E EPDM	11H	11H Hytrel
9J	9JE EPDM	10	10E EPDM	12H	12H Hytrel
10J	10JE EPDM	11	11E EPDM	6HS	6HS Split Hytrel
3JS	3JES EPDM Split	12	12E EPDM	7HS	7HS Split Hytrel
4JS	4JES EPDM Split	13	13E EPDM	8HS	8HS Split Hytrel
5JS	5JES EPDM Split	14	14E EPDM	9HS	9HS Split Hytrel
6JS	6JES EPDM Split	16	16E EPDM	10HS	10HS Split Hytrel
7JS	7JES EPDM Split	4N	4N Neoprene	11HS	11HS Split Hytrel
8JS	8JES EPDM Split	5N	5N Neoprene	12HS	12HS Split Hytrel
9JS	9JES EPDM Split	6N	6N Neoprene	13HS	13HS Split Hytrel
10JS	10JES EPDM Split	7N	7N Neoprene	14HS	14HS Split Hytrel
3JN	3JN Neoprene	8N	8N Neoprene	10U	10U Urethane
4JN	4JN Neoprene	9N	9N Neoprene	11U	11U Urethane
5JN	5JN Neoprene	10N	10N Neoprene	12U	12U Urethane
6JN	6JN Neoprene	11N	11N Neoprene		
7JN	7JN Neoprene	12N	12N Neoprene		
8JN	8JN Neoprene	13N	13N Neoprene		
3JNS	3JNS Neoprene Split	14N	14N Neoprene		
4JNS	4JNS Neoprene Split				
5JNS	5JNS Neoprene Split				
6JNS	6JNS Neoprene Split				
7JNS	7JNS Neoprene Split				
8JNS	8JNS Neoprene Split				

# Selection Guide

## Assembly Dimensions

All dimensions in mm

Flexible sleeves for Wood's Sure-Flex Plus couplings are available in four materials (EPDM, Neoprene, Hytrel and Urethane) and in three basic constructions. Characteristics of the materials are given on page 4 and the various types are shown and described here.



JE, JN

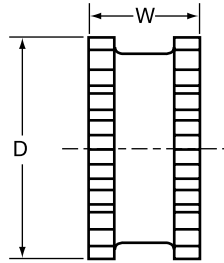

Types JES, JNS

### JE-JES-JN-JNS

J sleeves are molded EPDM rubber (E) or Neoprene (N). They are available in one-piece solid construction (JE, JN) or one-piece split construction (JES, JNS). These sleeves may be used in any Sure-Flex Plus flange within a given size.



E and N  
(Assembled)

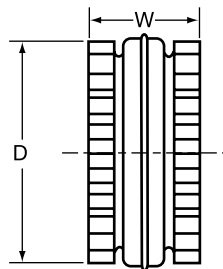

Types E and N  
(Disassembled)

### E-N

These sleeves are of two-piece design with a retaining ring. They are available in either EPDM (E) or Neoprene (N). They may be used with any flange within a given size. Sleeves are shown here assembled and disassembled.



H or U

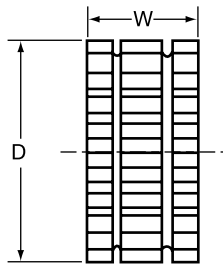

HS

### H-HS-U

H (Hytrel) and U (Urethane) sleeves, designed for high-torque applications, transmit four times as much power as an equivalent EPDM or Neoprene sleeve. Available in one-piece solid construction (H or U) or two-piece split construction (HS), these can be used only with S, C and SC flanges. They cannot be used with J or B flanges or as direct replacements for EPDM or Neoprene sleeves.

## Dimensions (mm)

Coupling Size	JE, JES, JN & JNS Sleeves EPDM & Neoprene			E and N Sleeves EPDM & Neoprene			H, U & HS Sleeves Hytrel & Urethane		
	D	W	Wt. kg	D	W	Wt. kg	D	W	Wt. kg
3	48	25	0.03	...	...	...	...	...	...
4	59	32	0.05	59	32	0.05	...	...	...
5	75	40	0.09	75	40	0.11	...	...	...
6	95	48	0.18	95	48	0.22	95	47	0.20
7	110	55	0.28	110	55	0.35	110	55	0.31
8	129	64	0.51	129	64	0.64	129	64	0.64
9*	152	76	0.66	152	76	0.95	152	76	0.82
10*	179	87	1.0	179	87	1.4	179	87	1.3
11	...	...	...	208	102	2.3	208	102	2.0
12	...	...	...	243	119	3.7	243	119	3.3
13	...	...	...	284	138	5.9	284	138	5.4
14	...	...	...	333	165	9.6	333	165	19
16	...	...	...	455	222	21	...	...	...

Size 13 and 14 Hytrel available as HS sleeves only.

\*All 9J and 10J sleeves available in EPDM only.

Only sizes available in Urethane.

# Selection Guide

## 1. Select Load Symbol based on your driven machine.

Application	Load Symbol	Application	Load Symbol	Application	Load Symbol
AGITATORS—Paddle, Propeller, Screw . . . . .	L	DEWATERING SCREEN (sewage) . . . . .	M	MILLS	
BAND RESAW (lumber) . . . . .	M	DISC FEEDER . . . . .	L	Ball, Pebble, Rod, Tube, Rubber Tumbling .H	
BARGE HAUL PULLER . . . . .	H	DOUGH MIXER . . . . .	M	Dryer and Cooler . . . . .	M
BARKING (lumber) . . . . .	H	DRAW BENCH CONVEYOR and MAIN DRIVE . . . . .	H	MIXERS	
BAR SCREEN (sewage) . . . . .	L	DREDGES		Concrete, Muller . . . . .	M
BATCHES (textile) . . . . .	L	Cable Reel, Pumps . . . . .	M	Banbury . . . . .	H
BEATER AND PULPER (paper) . . . . .	M	Cutter Head Drive, Jig Drive, Screen Drive .H		ORE CRUSHER . . . . .	H
BENDING ROLL (metal) . . . . .	M	Maneuvering and Utility Winch, Stacker . .M		OVEN CONVEYOR . . . . .	L
BLEACHER (paper) . . . . .	L	DYNAMOMETER . . . . .	L	PLANER (metal or wood) . . . . .	M
BLOWERS		DRYERS (rotary) . . . . .	M	PRESSES	
Centrifugal, Vane . . . . .	L	EDGER (lumber) . . . . .	H	Brick, Briquette Machine . . . . .	H
Lobe . . . . .	M	ELEVATOR		Notching, Paper, Punch, Printing . . . . .	M
BOTTLING MACHINERY . . . . .	L	Bucket . . . . .	M	PUG MILL . . . . .	M
BREW KETTLES (distilling) . . . . .	L	Escalator . . . . .	L	PULP GRINDER (paper) . . . . .	H
BUCKET ELEVATOR OR CONVEYOR . . . . .	M	Freight, Passenger, Service, Man Lift . . . .H		PULVERIZERS	
CALENDERS		ESCALATORS . . . . .	L	Hammermill—light duty, Roller . . . . .	M
Calender (paper) . . . . .	M	EXTRUDER (metal) . . . . .	H	Hammermill—heavy duty, Hog . . . . .	H
Calender-super (paper), Calender (rubber) .H		FANS		PUMPS	
CANE KNIVES (sugar) . . . . .	M	Centrifugal . . . . .	L	Centrifugal, Axial . . . . .	L
CARD MACHINE (textile) . . . . .	H	Cooling Tower . . . . .	H	Gear, Lobe, Screw, Vane . . . . .	M
CAR DUMPERS . . . . .	H	Forced Draft, Large Industrial or Mine . . .M		Reciprocating—sgl. or dbl. acting, cylinder . . . . .	*
CAR PULLERS . . . . .	M	FEEDERS		REEL, REWINDER (paper) CABLE . . . . .	M
CEMENT KILN . . . . .	H	Apron, Belt, Disc . . . . .	L	ROD MILL . . . . .	H
CENTRIFUGAL EQUIPMENT		Reciprocating . . . . .	H	SAWDUST CONVEYOR . . . . .	L
Blowers, Compressors, Fans, Pumps . . . .L		Screw . . . . .	M	SCREENS	
CHEMICAL FEEDERS (sewage) . . . . .	L	FILTER, PRESS-OIL . . . . .	M	Air Washing, Water . . . . .	L
CHILLER (oil) . . . . .	M	GENERATORS		Rotary for coal or sand . . . . .	M
CHIPPER (paper) . . . . .	H	Uniform load . . . . .	L	Vibrating . . . . .	H
CIRCULAR RESAW (lumber) . . . . .	M	Varying load, Hoist . . . . .	M	SCREW CONVEYOR . . . . .	L
CLARIFIER or CLASSIFIER . . . . .	L	Welders . . . . .	H	SLAB CONVEYOR (lumber) . . . . .	M
CLAY WORKING MACHINERY . . . . .	M	GRIT COLLECTOR (sewage) . . . . .	L	SLITTERS (metal) . . . . .	M
COLLECTORS (sewage) . . . . .	L	GRIZZLY . . . . .	H	SOAPERS (textile) . . . . .	L
COMPRESSORS		HAMMERMILL		SORTING TABLE (lumber) . . . . .	M
Centrifugal, Gear, Lobe, Screw . . . . .	L	Light Duty, Intermittent . . . . .	M	SPINNER (textile) . . . . .	M
Reciprocating . . . . .	*	Heavy Duty, Continuous . . . . .	H	STOKER . . . . .	L
CONCRETE MIXERS . . . . .	M	HOISTS		SUCTION ROLL (paper) . . . . .	M
CONVERTING MACHINE (paper) . . . . .	M	Heavy Duty . . . . .	H	TENTER FRAMES (textile) . . . . .	M
CONVEYORS		Medium Duty . . . . .	M	TIRE BUILDING MACHINES . . . . .	H
Apron, Assembly Belt, Flight, Oven, Screw .L		JORDAN (paper) . . . . .	H	TIRE & TUBE PRESS OPENER . . . . .	L
Bucket . . . . .	M	KILN, ROTARY . . . . .	H	TUMBLING BARRELS . . . . .	H
COOKERS—Brewing, Distilling, Food . . . .L		LAUNDRY WASHER or TUMBLER . . . . .	H	WASHER and THICKENER (paper) . . . . .	M
COOLING TOWER FANS . . . . .	H	LINE SHAFTS . . . . .	L	WINCHES . . . . .	M
COUCH (paper) . . . . .	M	LOG HAUL (lumber) . . . . .	H	WINDERS, Paper, Textile, Wire . . . . .	M
CRANES and HOISTS . . . . .	M	LOOM (textile) . . . . .	M	WINDLASS . . . . .	M
Heavy Duty Mine . . . . .	H	MACHINE TOOLS, MAIN DRIVE . . . . .	M	WIRE	
CRUSHERS—Cane (sugar), Stone or Ore . . .H		MANGLE (textile) . . . . .	L	Drawing . . . . .	H
CUTTER—Paper . . . . .	H	MASH TUBS (distilling) . . . . .	L	Winding . . . . .	M
CYLINDER (paper) . . . . .	H	MEAT GRINDER . . . . .	M	WOODWORKING MACHINERY . . . . .	L
		METAL FORMING MACHINES . . . . .	M		

\*Consult Factory

## 2. Determine Service Factor using Load Symbol and Driver

Load Symbol	L Light	M Medium	H Heavy
Standard AC Motor			
DC Shunt Motor	1.25	1.5	2.0
*Engine, 8 or more cylinders			
High Torque AC Motor			
DC Series & Comp.	1.5	2.0	2.5
*Engine, 4-6 cylinders			
*Engine, 3 cylinders or less	2.0	2.5	3.0
Turbine	1.0	1.25	1.5

\* On applications involving varying torque loads, design around the maximum load. Then determine the resulting service factor at minimum load. If this value is greater than 5.2 for EPDM or Neoprene sleeves, or 4.0 for Hytrel sleeves, special coupling alignment will be required (see page 17).

**Caution:** Applications involving reciprocating engines and reciprocating driven devices are subject to rotational vibrational critical speeds which may destroy the coupling. Consult factory.

## 3. Determine Size using Coupling Rating Tables

Use the following formula to calculate the required coupling kilowatt rating @ 100 RPM.  
 $KW @ 100 \text{ RPM} = KW \times \text{Service Factor} \times 100 / \text{coupling RPM}$

Use the chart below to find a coupling with a KW @ 100 RPM rating which is greater than calculated above.

Example: For 4 KW @ 55 RPM, 1.25 Service Factor:  
 $KW @ 100 = 4 \times 1.25 \times 100 / 55 = 9.09$   
 Use #12 EPDM or Neoprene, or #10 Hytrel.

Note: Do not exceed a 5.2 Service Factor for EPDM or Neoprene sleeves, or 4.0 for Hytrel sleeves.

### Online Selection Tools

Coupling selection program, 3-D CAD models, e-catalog and interchange guide make selecting the right coupling simple!  
[www.TBWoods.com/Couplings](http://www.TBWoods.com/Couplings)

**New! Sure-Flex Plus EPDM and Neoprene sleeves have a 30% higher torque capacity.**

### Coupling Ratings (Metric)

Size	EPDM Sleeve	Neoprene Sleeve	KW @ RPM				Torque (Nm)	Stiffness (Nm/rad)	Max RPM
			100	970	1450	3000			
3	JE,JES	JN,JNS	0.09	0.90	1.3	2.8	8.8	26	9200
4	E,JE,JES	N,JN,JNS	0.18	1.8	2.7	5.5	18	52	7600
5	E,JE,JES	N,JN,JNS	0.37	3.6	5.4	11	35	104	7600
6	E,JE,JES	N,JN,JNS	0.69	6.7	10	21	66	194	6000
7	E,JE,JES	N,JN,JNS	1.1	11	16	33	107	313	5250
8	E,JE,JES	N,JN,JNS	1.8	17	25	52	167	490	4500
9	E,JE,JES	N	2.8	27	40	83	264	777	3750
10	E,JE,JES	N	4.4	43	64	133	422	1241	3600
11	E	N	7.0	68	101	209	666	1955	3600
12	E	N	11	107	161	332	1058	3107	2800
13	E	N	17	169	253	524	1667	4898	2400
14	E	N	28	269	402	831	2644	7768	2200
16	E	-	56	542	811	1677	5338	20392	1500

Size	Hytrel Sleeve	Urethane Sleeve	KW @ RPM				Torque (Nm)	Stiffness (Nm/rad)	Max RPM
			100	970	1450	3000			
6	H, HS		2.1	21	31	64	203	1130	6000
7	H, HS		3.4	33	49	102	325	2260	5250
8	H, HS		5.4	52	78	161	512	3390	4500
9	H, HS		8.5	83	124	256	814	5367	3750
10	H, HS	U	13	130	195	403	1282	11299*	3600
11	H, HS	U	21	207	309	639	2034	14123*	3600
12	H, HS	U	37	362	540	1118	3559	25422*	2800
13	HS		56	542	811	1678	5341	41680	2400
14	HS		86	832	1243	2573	8189	67028	2200

\* Urethane values are 220000, 350000, and 600000.





# Type S Sure-Flex Plus®

## BTS - Close Coupled Applications

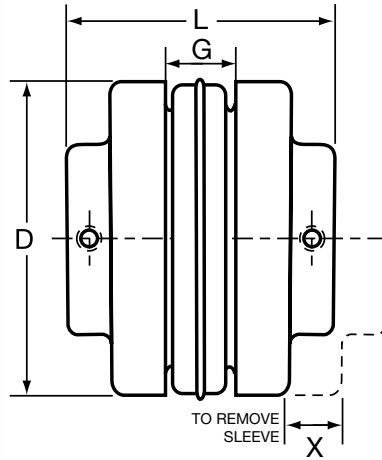

### Couplings

Spacing between shafts should be greater than 1/8 in. and less than L minus .85 times the sum of the two bore diameters. Spacing between internal flange hubs equals  $L - 2^*C$ . To order couplings, refer to the part number examples on page 3.

Metric bore tolerance meets F7 clearance fit (ISO/R775:1969,mm)

### Dimensions

Stock Bores (mm)																Max Bore in. (mm)		Shallow Keyseat Dimensions ② (in.)																			
14	15	16	19	20	24	25	28	30	32	35	38	42	45	48	50	52	55	60	65	70	80	90	① Standard Keyseat	② Shallow Keyseat	Bore	K.S.	Key	Bore	K.S.	Key	Bore	K.S.	Key				
X	X	X	X	X	X	X	X																	1-3/16 (30)	1-1/4 (32)	1-1/4	1/4 X 1/16	1/4 X 3/16 X 1-3/8	...	...	...	...	...	...	...	...	
	X		X	X	X	X	X	X	X	X														1-7/16 (37)	1-1/2 (38) ④	...	...	...	...	...	...	...	...	...	...	...	
										X														...	1-3/4	1-1/2 & 1-5/8	3/8 X 1/8	3/8 x 5/16 X ④	1-3/4	3/8 X 1/16	3/8 X 1/4 X 1-1/4	...	...	...	1-7/8	1/2 X 1/16	1/2 X 5/16 X 1-9/16
																								...	1-7/8	...	...	...	...	...	...	...	...	...	...		
			X	X	X	X	X	X	X	X	X													1-5/8 (41)	1-7/8 (48)	1-7/8	1/2 X 1/8	1/2 X 3/8 X 1-7/8	...	...	...	...	...	...	...	...	
				X	X	X	X	X	X	X	X													1-15/16 (49)	2-1/4 (57) ④	2-1/8	1/2 X 3/16	1/2 X 7/16 X 2-1/8	...	...	...	...	...	...	...	...	
																								...	2-3/8	...	...	...	2-3/8	5/8 X 1/8	5/8 X 7/16 X 1-7/8	...	...	...			
				X		X	X	X	X	X														2-1/2 (64)	2-3/4 (70) ④	...	...	...	...	...	...	...	...	...	...		
																								...	2-7/8	2-7/8	3/4 X 1/8	3/4 X 1/2 X 2-1/4	...	...	...	...	...	...	...	...	
								X	X	X	X	X	X	X	X	X								2-3/4 (70)	3-1/8 (79) ④	2-7/8	3/4 X 1/4	3/4 X 5/8 X 2-3/4	...	...	...	...	...	...	...	...	
																								...	3-3/8	...	...	...	3-3/8	7/8 X 3/16	7/8 X 5/8 X 2-5/8	...	...	...			
										X	X	X	X		X	X	X	X						3-3/8 (86)	3-7/16 (87) ④	3-7/16	7/8 X 3/16	7/8 X 5/8 X 3-7/16	...	...	...	...	...	...	...	...	
																								...	3-7/8	3-7/8	1 X 1/4	1 X 3/4 X 3	...	...	...	...	...	...	...	...	
														X		X	X	X	X					3-7/8 (98)	3-15/16 (100)	...	...	...	...	...	...	...	...	...	...	...	
																								4-1/2 (114)	...	...	...	...	...	...	...	...	...	...	...		
																								5 (127)	...	...	...	...	...	...	...	...	...	...	...		
																								5-1/2 (140)	6 (152)	...	...	...	...	...	...	...	...	...	...		

① See charts on page 11.

② Some large bore Type S flanges are supplied with shallow keyseats. In these cases, a rectangular key is furnished. The bores involved are listed above.

③ 1-5/8 for 1-1/2 bore, 1-5/16 for 1-5/8 bore.

④ Altered bores available only up to this diameter.

# Type J Sure-Flex Plus®

## BTS - Close Coupled Applications

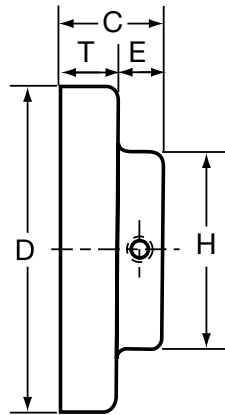

### Flanges

Type J flanges sizes 3, 4 and 5 are manufactured of sintered carbon steel. The powdered metal manufacturing process provides high dimensional accuracy and uniform material properties for high strength. Size 6 is made of high strength cast iron. Flanges are bored-to-size for a slip fit on standard shafts. The outside face of the flange is precision machined, allowing the surface to be used to align the coupling without special tools. Type J flanges can be used with EPDM and Neoprene sleeves. Each flange has a standard keyway, one setscrew over the keyway and one setscrew at 90° from the keyway.

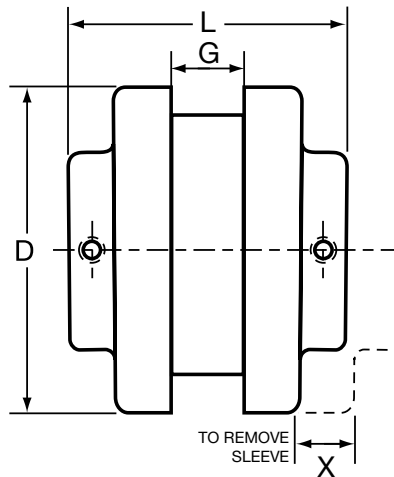

### Couplings

Spacing between internal flange hubs equals G. Spacing between shafts should be greater than 3.2mm and less than L minus .85 times the sum of the two bore diameters.

To order couplings, refer to the part number examples on page 3. When specifying Type J flanges, the coupling and bore sizes accompany the flange symbol "J". For example, 3J x 1/2 is 3J12.

## Dimensions

Size	Dimensions (mm)								Wt. (kg)	STOCK BORES*																							
	C	D	E	G	H	L	T	X		(Inches)						Max Bore (mm)	(Millimeters)																
										3/8	1/2	5/8	3/4	7/8	15/16		1	1-1/8	1-3/16	1-1/4	1-3/8	9	11	12	14	15	16	19	20	24	25		
3J	20	52	10	10	38	50	10	16	0.14	X	X	X	X	X						7/8 (22)	X	X	X	X	X	X							
4J	22	63	11	16	41	60	11	16	0.18		X	X	X	X	X	X				1 (25)			X	X	X	X	X	X	X	X	X		
5J	27	83	12	19	48	72	15	23	0.41		X	X	X	X	X	X	X			1-1/8 (29)													
6J	33	102	14	22	64	89	19	28	0.54			X	X	X	X	X	X	X	X	1-3/8 (35)													

\* See page 11 for standard keyseat dimensions and page 8 for bore tolerances.

■ Approximate weight for each flange.

# Type B Sure-Flex Plus®

## QD - Closed Coupled Applications

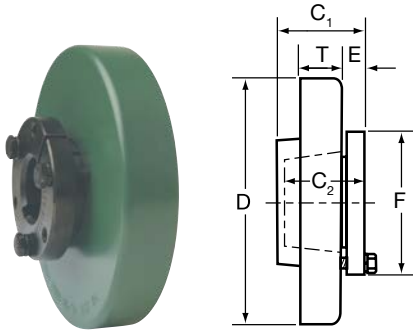

### Flanges

Type B flanges are made of high-strength cast iron and are designed to accommodate Wood's Sure-Grip Bushings for easy installation and removal.

### Bushings

Sure-Grip Bushings offer convenient mounting of the flange to the shaft securely without setscrews. They are tapered and are split through both the bushing flange and taper to provide a clamp fit, eliminating wobble, vibration and fretting corrosion. This is the same bushing used in Wood's sheaves and pulleys and is readily available everywhere.

### Dimensions (mm)

Part Number	Bushing Required	Dimensions										Max Bore*	Weight (kg) ■	
		C <sub>1</sub>	C <sub>2</sub>	D	E	F	G	L	T	X	Flange		Bushing	
6B	JA	31	25	102	12	51	22	86	20	28	32	0.64	0.36	
7B	JA	41	25	117	12	51	25	89	20	33	32	0.86	0.36	
8B	SH	48	32	138	14	68	29	103	23	28	41	1.3	0.45	
9B	SD	57	46	161	16	97	37	121	27	45	49	2.2	0.68	
10B	SK	49	48	191	18	98	41	140	31	51	64	3.5	0.91	
11B	SF	56	51	219	17	117	48	159	38	60	75	5.4	1.6	
12B	E	69	67	254	23	152	54	191	43	65	89	8.2	4.1	
13B	F	95	92	298	27	168	68	222	50	76	100	14	6.4	
14B	F	95	92	352	27	168	83	251	57	89	100	23	6.4	
16B	J	122	114	479	32	184	121	324	70	108	114	54	10	

\*Maximum bore with keyseat. ■ Approximate weight for each flange.

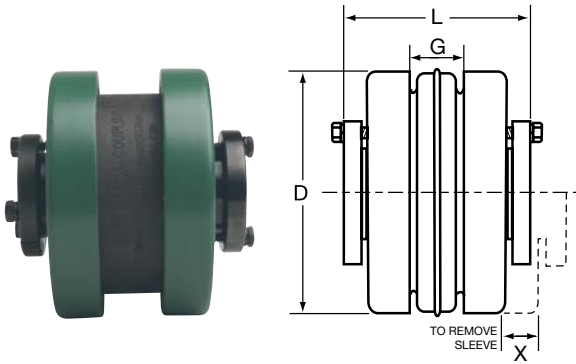

### Couplings

Type B Sure-Flex Plus couplings can use any EPDM and Neoprene sleeves. Do not use Hytrel sleeves with Type B couplings.

Spacing between internal flange hubs equals L minus 2 times C<sub>2</sub>. Spacing between shafts should be greater than 3.2 mm and less than G.

To order complete couplings, specify coupling size with flange symbol (B) and bushing. Refer to page 3 to order the required coupling. Refer to charts below for bushings.

### Sure-Grip® Bushing Keyseat Dimensions (mm)

Bushing	Bore	Keyseat	Bushing	Bore	Keyseat	Bushing	Bore	Keyseat	Shaft Dia.	Width	Depth
JA	15-16	5 x 5	SF	28-30	8 x 7	J	50	14 x 9	1/2 - 9/16	1/8	1/16
	19-20	6 x 6		32-38	10 x 8		55	16 x 10	5/8 - 7/8	3/16	3/32
	24-25	8 x 6*		40-42	12 x 8		60-65	18 x 11	15/16 - 1-1/4	1/4	1/8
	28	8 x 5*		45-50	14 x 9		70-75	20 x 12	1-5/16 - 1-3/8	5/16	5/32
SH	24-30	8 x 7	E	55	16 x 10	*Shallow key furnished	80-85	22 x 14	1-7/16 - 1-3/4	3/8	3/16
	32-35	10 x 8		60	18 x 11		1-13/16 - 2-1/4	1/2	1/4		
	40-42	12 x 8		65	18 x 8*		2-5/16 - 2-3/4	5/8	5/16		
SDS	24-30	8 x 7	F	45-50	14 x 9		2-13/16 - 3-1/4	3/4	3/8		
	32-38	10 x 8		55	16 x 10		3-5/16 - 3-3/4	7/8	7/16		
	40-42	12 x 8		60-65	18 x 11		3-13/16 - 4-1/2	1	1/2		
SD	24-30	8 x 7	70-75	20 x 12	4-9/16 - 5-1/2		1-1/4	5/8			
	32-38	10 x 8	80	22 x 11*	5-9/16 - 6-1/2		1-1/2	3/4			
	40-42	12 x 8									
SK	24-30	8 x 7									
	32-38	10 x 8									
	40-42	12 x 8									
	45-50	14 x 9									
	55	16 x 10									

# Type SC Spacer Couplings

## BTS - Conventional Spacer Design

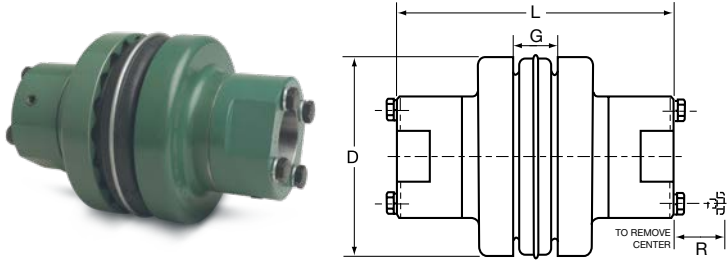

For other distances between shaft ends not shown here, please see page F1-16 of P-1690-TBW or use the Coupling Selection Program at [www.TBWoods.com/Select](http://www.TBWoods.com/Select)

For dimensions of separate Type SC Spacer components, refer to page 13.

### Flanges (mm)

Coupling Size	Required Distance Between Shafts	Use Flange Number	Use Hub Number	Maximum Bore		Dimensions (mm)				Weight (kg) ■
				in.	mm	D	L <sup>②</sup>	G	R	
4JSC <sup>①</sup>	89	4JSC35	...	1-1/8	29	62	143	16	...	1.2
5SC	89	5SC35	5SCH	1-1/8	29	83	143	19	15	2.0
6SC	89	6SC35	6SCH-6SCHS	1-3/8	35	102	149	22	19	3.3
	112	6SC44	6SCH-6SCHS	1-3/8	35	102	171	22	19	3.7
	127	6SC50	6SCH-6SCHS	1-3/8	35	102	187	22	19	4.0
	89	7SC35	7SCH-7SCHS	1-5/8	42	117	162	25	16	4.5
7SC	112	7SC44	7SCH-7SCHS	1-5/8	42	117	184	25	16	4.9
	127	7SC50	7SCH-7SCHS	1-5/8	42	117	200	25	16	5.2
	89	8SC35	8SCH-8SCHS	1-7/8	48	138	175	29	21	6.9
	89	8SC35-10	10SCH-10SCHS	2-3/8	60	138	206	29	21	11
8SC	112	8SC44	8SCH-8SCHS	1-7/8	48	138	197	29	21	7.4
	127	8SC50	8SCH-8SCHS	1-7/8	48	138	213	29	30	7.9
	127	8SC50-10	10SCH-10SCHS	2-3/8	60	138	244	29	30	12
	89	9SC35	9SCH-9SCHS	2-1/8	54	161	191	37	27	8.4
9SC	112	9SC44	9SCH-9SCHS	2-1/8	54	161	210	37	27	10
	127	9SC50	9SCH-9SCHS	2-1/8	54	161	225	37	27	11
	127	9SC50-11	11SCH-11SCHS	2-7/8	73	161	264	37	30	18
	178	9SC70-11	11SCH-11SCHS	2-7/8	73	161	314	37	30	22
	197	9SC78-11	11SCH-11SCHS	2-7/8	73	161	333	37	30	23
	112	10SC48	10SCH-10SCHS	2-3/8	60	191	238	41	30	17
10SC	127	10SC50	10SCH-10SCHS	2-3/8	60	191	244	41	48	17
	178	10SC70-13	13SCH-13SCHS	3-3/8	86	191	346	41	48	33
	197	10SC78-13	13SCH-13SCHS	3-3/8	86	191	365	41	48	34
	254	10SC100-13	13SCH-13SCHS	3-3/8	86	191	422	41	48	40
	112	11SC48	11SCH-11SCHS	2-7/8	73	219	262	48	30	25
	127	11SC50	11SCH-11SCHS	2-7/8	73	219	264	18	30	25
11SC	178	11SC70-14	14SCH	3-7/8	98	219	371	18	51	39
	197	11SC78-14	14SCH	3-7/8	98	219	391	18	51	41
	254	11SC100-14	14SCH	3-7/8	98	219	448	18	51	47
	178	12SC70	12SCH-12SCHS	2-7/8	73	254	327	59	38	40
12SC	178	12SC70-14	14SCH	3-7/8	98	254	371	59	51	45
	197	12SC78	12SCH-12SCHS	2-7/8	73	254	346	59	38	42
	197	12SC78-14	14SCH	3-7/8	98	254	391	59	51	47
	254	12SC100-14	14SCH	3-7/8	98	254	448	59	51	52
13SC	197	13SC78	13SCH-13SCHS	3-3/8	86	248	365	68	48	59
14SC	197	14SC78	14SCH	3-7/8	98	352	391	83	51	82

■ Approximate weight for each flange.

① 4JSC35 x 1-1/8 has shallow keyseat. ② "L" dimension and weight will change if one or two short (HS) hubs used.

Note: Refer to pages 13-14 to order — specify components separately

# Type SC Couplings and Flanges and Hubs

## Type SC Flanges and Hubs

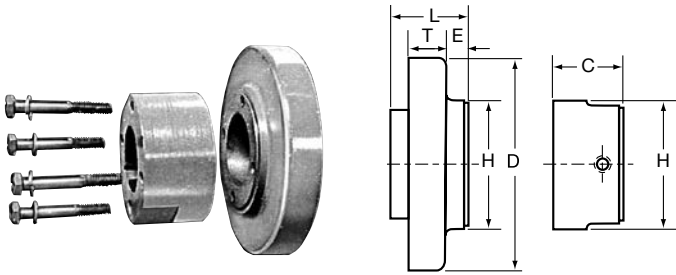

Tables on pages 13-14 provide dimensional information for flanges and hubs used for Spacer Couplings. For assembled dimensions, see table on page 12. Any of the sleeves shown on page 5 may be used.

### Flanges (mm)

Coupling Size	Flange Number	For Distance Between Shafts*	For Hub	Dimensions (mm)					Weight (kg) ■
				D	E	H	L	T	
4JSC	4JSC35	79		62	52	51	64	11	.59
5SC	5SC35	89	5SCH	83	20	51	43	15	.59
	6SC35	89	6SCH-6SCHS	102	15	64	41	18	.91
6SC	6SC44	112	6SCH-6SCHS	102	26	64	52	18	1.9
	6SC50	127	6SCH-6SCHS	102	34	64	60	18	1.2
7SC	7SC35	89	7SCH-7SCHS	117	12	71	41	20	1.1
	7SC44	112	7SCH-7SCHS	117	23	71	52	20	1.4
	7SC50	127	7SCH-7SCHS	117	31	71	60	20	1.5
8SC	8SC35	89	8SCH-8SCHS	138	7	83	41	23	1.7
	8SC35-10	89	10SCH-10SCHS	138	7	111	41	23	1.6
	8SC44	112	8SCH-8SCHS	138	18	83	52	23	2.0
	8SC50	127	8SCH-8SCHS	138	26	83	60	23	2.2
9SC	8SC50-10	127	10SCH-10SCHS	138	26	111	60	23	2.5
	9SC35	89	9SCH-9SCHS	161	2	92	43	26	1.9
	9SC44	112	9SCH-9SCHS	161	11	92	52	26	2.7
	9SC50	127	9SCH-9SCHS	161	19	92	60	26	2.9
	9SC50-11	127	11SCH-11SCHS	161	19	133	60	26	3.2
10SC	9SC70-11	178	11SCH-11SCHS	161	44	133	86	26	4.9
	9SC78-11	197	11SCH-11SCHS	161	54	133	95	26	5.6
	10SC48	112	10SCH-10SCHS	191	9	111	57	31	4.5
	10SC50	127	10SCH-10SCHS	191	12	111	60	31	4.6
	10SC70-13	178	13SCH-13SCHS	191	37	156	86	31	6.6
11SC	10SC78-13	197	13SCH-13SCHS	191	47	156	95	31	7.5
	10SC100-13	254	13SCH-13SCHS	191	50	156	124	31	10
	11SC48	112	11SCH-11SCHS	219	1	133	38	38	5.7
	11SC50	127	11SCH-11SCHS	219	2	133	40	38	5.7
	11SC70-14	178	14SCH	219	27	165	65	38	7.4
12SC	11SC78-14	197	14SCH	219	37	165	75	38	8.4
	11SC100-14	254	14SCH	219	65	165	103	38	11
	12SC70	178	12SCH-12SCHS	254	17	146	63	43	11
	12SC70-14	178	14SCH	254	17	165	63	43	9.7
	12SC78	197	12SCH-12SCHS	254	26	146	72	43	11
13SC	12SC78-14	197	14SCH	254	26	165	72	43	11
	12SC100-14	254	14SCH	254	55	165	101	43	13
14SC	13SC78	197	13SCH-13SCHS	298	14	156	83	50	17
	14SC78	197	14SCH	352	1	165	69	57	25

\*Flanges can be mixed to form different Between-Shaft Dimensions. See chart page 15. ■ Approximate weight for each flange.

▲ If using 10HS hub, 7/16-14NC x 2-1/4 long capscrew needed (not furnished).

# Type SC Couplings Flanges and Hubs

## Type SC Flanges and Hubs

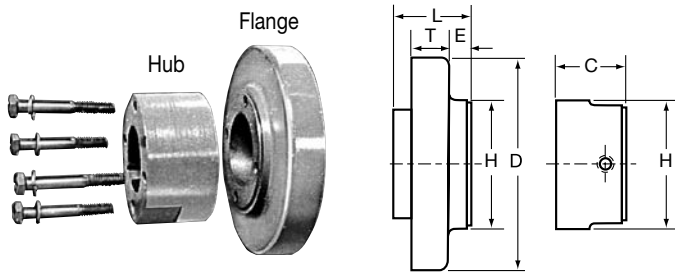

Tables on pages 13-14 provide dimensional information for flanges and hubs used for Spacer Couplings. For assembled dimensions, see table on page 12. Any of the sleeves shown on page 5 may be used.

### Hubs

Coupling Size	Hub Number	Maximum Bore		Stock Bores* (in)		Dimensions (mm)			Weight (kg) ■
		in	mm	Plain Bore	Bore with Standard Keyway & SetScrew	C	H	Cap Screws Furnished (in.)	
4JSC	†	1-1/8	29	...	5/8 - 7/8 - 1 - 1-1/8*	27	51	...	...
5SC	5SCH	1-1/8	29	1/2	5/8 - 3/4 - 7/8 - 1 - 1-1/8	28	51	4-10 x 1-1/2	.36
6SC	6SCH	1-3/8	35	5/8	3/4 - 7/8 - 1 - 1-1/8 - 1-1/4 - 1-3/8	31	64	4-1/4 x 1-3/4	.64
	6SCHS	7/8	22	...	7/8	25	64	4-1/4 x 1-1/2	.50
7SC	7SCH	1-5/8	41	5/8	7/8 - 1 - 1-1/8 - 1-3/8 - 1-1/2 - 1-5/8	37	71	4-1/4 x 1-7/8	.91
	7SCHS	7/8	22	...	7/8	28	71	4-1/4 x 1-1/2	.68
8SC	8SCH	1-7/8	48	3/4	7/8 - 1 - 1-1/8 - 1-3/8	44	83	4-5/16 x 2-1/4	1.5
	8SCHS	7/8	22	...	1-1/2 - 1-5/8 - 1-3/4 - 1-7/8	31	83	4-5/16 x 1-3/4	.91
9SC	9SCH	2-1/8	54	7/8	1 - 1-1/8 - 1-3/8 - 1-1/2	50	92	4-3/8 x 2-3/4	1.9
	9SCHS	1-1/2	38	...	1-5/8 - 1-3/4 - 1-7/8 - 2-1/8	39	92	4-3/8 x 2-1/4	1.7
10SC	10SCH	2-3/8	60	1-1/8	1-5/8 - 1-7/8 - 2-1/8 - 2-3/8	60	111	4-7/16 x 3-1/4	3.4
	10SCHS	1-5/8	41	...	1-1/8	42	111	4-7/16 x 2-1/2	2.5
11SC	11SCH	2-7/8	73	1-1/8	1-7/8 - 2-1/8 - 2-3/8 - 2-7/8	69	133	4-1/2 x 3-1/2	5.5
	11SCHS	1-7/8	48	...	1-1/8 - 1-5/8	48	133	4-1/2 x 2-3/4	4.2
12SC	12SCH	2-7/8	73	1-3/8	2-1/8 - 2-3/8 - 2-7/8	75	146	4-5/8 x 4	7.5
	12SCHS	2-1/2	64	...	2-3/8	64	146	4-5/8 x 3-1/2	6.4
13SC	13SCH	3-3/8	86	1-3/8	2-3/8 - 2-7/8 - 3-3/8	85	156	4-5/8 x 4-1/2	9.0
	13SCHS	2-1/2	64	...	2-1/8 - 2-3/8	63	156	4-5/8 x 3-1/2	7.3
14SC	142SCH	3-7/8	98	1-5/8	2-3/8 - 2-7/8 - 3-3/8 - 3-7/8	98	165	4-5/8 x 5	11

† For 4JSC the hub is an integral part of the flange. 4JSC x 1-1/8 has 1/4 x 1/16 shallow keyseat. ■ Approximate weight for each hub.

\* See page 8 for bore tolerances, page 11 for standard keyseat dimensions.

# Type SC Spacer Couplings

## Between Shaft Spacing

Spacer couplings are available for most popular between-shaft dimensions. Other spacings can be achieved by mixing flanges.

The “Standard” column provides spacings using identical flanges; the “Combination” column mixes flanges; the column headed “Semi-Spacer” uses one flange that is not made for spacer coupling applications and thus does not have a detachable hub.

To select couplings for various DBSEs, please see our Coupling Selector Program at [www.TBWoods.com/Select](http://www.TBWoods.com/Select)

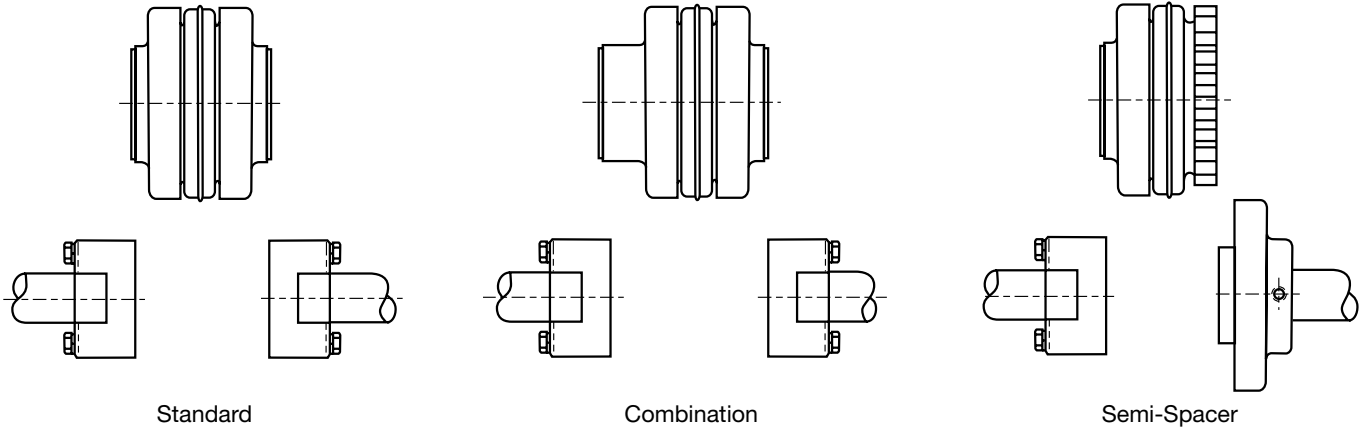

Standard (mm)	
Spacing	Uses Flanges*
80	2-( )SC35
111	2-( )SC44
127	2-( )SC50
178	2-( )SC70
197	2-( )SC78
254	2-( )SC100

Combination (mm)	
Spacing	Uses Flanges*
100	SC35 & SC44
108	SC35 & SC50
119	SC44 & SC50
133	SC35 & SC70
143	SC35 & SC78
144	SC44 & SC70
152	SC50 & SC70
154	SC44 & SC78
162	SC50 & SC78
171	SC35 & SC100
183	SC44 & SC100
187	SC70 & SC78
191	SC50 & SC100
216	SC70 & SC100
225	SC78 & SC100

Semi-Spacer (mm)	
Spacing	Uses Flanges*
48	S & SC35
58	S & SC44
67	S & SC50
92	S & SC70
102	S & SC78
130	S & SC100

\* Check individual coupling size for flange availability.  
Note: Other Combinations available — consult factory.

# Type C Sure-Flex Plus®

## Clamp Hub Spacer and Design

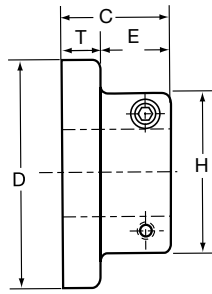

### Flanges

Sure-Flex Plus® Type C Clamp Hub flanges employ integral locking collars and screws to assure a clamp fit on the shaft. One setscrew is furnished over the key. They are designed primarily for applications where flanges must be removed from one or both shafts without moving either the driver or driven units. A typical application is a screw compressor which uses a replaceable face seal around the input shaft.

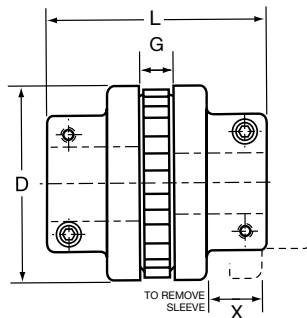

### Couplings

Type C Clamp Hub Couplings normally use Hytrel sleeves. However, any of the sleeves shown on page 5 can be used. Type C couplings may often be used where spacer couplings are required.

Spacing between internal flange hubs equals G. To order complete couplings, specify coupling size with flange symbol (C), giving bore required. Refer to page 3 to order the required coupling.

## Dimensions (mm)

Product Number	Stock Bores	Min Bore		Maximum Bore				Distance Between Shafts		Dimensions (mm)								Approx. Weight (kg.)*
		in.	mm	Standard KS		Shallow KS		Min	Max	C	D	E	G	H	L	X		
				in.	mm	in.	mm											
6C	1-1/8, 1-7/8, 40mm	7/8	22	1-5/8	41	1-7/8	48	2 (51mm)	2-3/4 (70mm)	49	102	29	22	76	121	25	1.6	
7C	1-3/8, 1-7/8, 35mm, 40mm	1-1/8	29	1-7/8	48	...	...	2-5/16 (59mm)	3-7/16 (87mm)	71	117	36	27	83	138	30	2.0	
8C	1/3/8, 1-5/8, 1-3/4, 1-7/8 2-1/8, 2-1/4, 2-3/8, 40mm	1-3/8	35	2-1/4	57	2-3/8	60	2-9/16 (65mm)	4 (102mm)	64	138	40	29	98	156	35	3.0	
9C	1-5/8, 1-3/4, 1-7/8, 2, 2-1/8, 2-1/4, 2-3/8, 2-1/2	1-5/8	41	2-1/2	64	2-5/8	68	3-1/16 (78mm)	4-5/8 (117mm)	76	161	50	37	108	189	40	4.5	
10C	1-5/8, 1-7/8, 2-1/4, 2-3/8, 2-1/2	1-5/8	41	2-7/8	73	...	...	3-9/16 (90mm)	5-1/4 (133mm)	89	191	58	43	127	221	46	7.5	
11C	2-1/8, 2-3/8, 2-1/2	1-7/8	48	3-3/8	86	...	...	4-1/8 (105mm)	5-7/8 (149mm)	102	219	63	48	137	251	54	12	
12C	2-1/8	1-7/8	48	3-3/8	86	...	...	4-7/8 (124mm)	6-1/2 (165mm)	111	254	68	60	152	283	60	17	

For Standard Keyseat dimensions, see chart page 11. \*Weight of one flange.

### Bore Tolerances for Type C Flanges

These bores provide a slip fit.

Bore (in.)	Tolerance (in.)
Up to and including 2"	+ .0005 to + .0015
Over 2"	+ .0005 to + .0020

### Shallow Keyseat Dimensions

Some large bore Type C flanges are supplied with shallow keyseats. In these cases, a rectangular key is furnished. The flanges and bores involved are as follows:

Size	Bore Range	KS	Key Furnished
6C	1-11/16 to 1-7/8	1/2 x 1/16	1/2 x 5/16 x 1-15/16
8C	2-5/16 to 2-3/8	5/8 x 1/16	5/8 x 3/8 x 2-1/2
9C	2-7/16 to 2-11/16	5/8 x 3/16	5/8 x 1/2 x 3

Metric bore tolerance meets F7 clearance fit (ISO/R775:1969, mm)



# Installation Instructions

Sure-Flex Plus flanges (outer metallic parts) and sleeves (inner elastomeric elements) come in many sizes and types. First, determine the size and type of components being used. Check maximum RPM values in the table below against operating speed. Remove all components from their boxes, and loosely assemble the coupling on any convenient surface. (If using a two-piece E or N sleeve, do not install the wire ring at this time.)

**1.** Inspect all coupling components and remove any protective coatings or lubricants from bores, mating surfaces and fasteners. Remove any existing burrs, etc. from the shafts.

**2.** Slide one coupling flange onto each shaft using keys where required. When using Type B flanges, follow the instructions furnished with the Sure-Grip bushings.

**3.** Position the flanges on the shafts to approximately achieve the  $G_1$  dimension shown in the table. It is usually best to have an equal length of shaft extending into each flange. Move one flange to its final position. Torque fasteners to proper values. Slide the other flange far enough away to install the sleeve. With a two-piece sleeve, do not move the wire ring to its final position; allow it to hang loosely in the groove adjacent to the teeth.

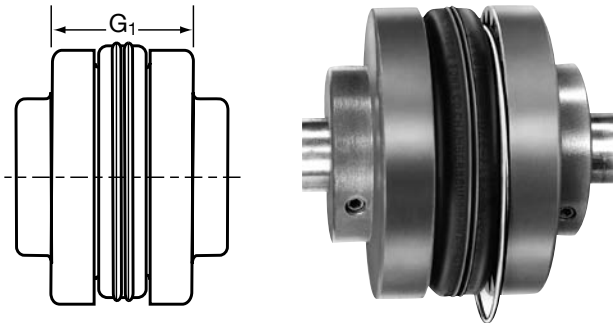

**4.** Slide the loose flange on the shaft until the sleeve is completely seated in the teeth of each flange. (The “ $G_1$ ” dimension is for reference and not critical.) Secure the flange to the shaft. Different coupling sleeves require different degrees of alignment precision. Locate the alignment values for your sleeve size and type in the table.

**5.** Check parallel alignment by placing a straight-edge across the two coupling flanges and measuring the maximum offset at various points around the periphery of the coupling without rotating the coupling. If the maximum offset exceeds the figure shown under “Parallel” in the table, realign the shafts.

**6.** Check angular alignment with a caliper. Measure from the outside of one flange to the outside of the other at intervals around the periphery of the coupling. Determine the maximum and minimum dimensions without rotating the coupling. The difference between the maximum and minimum must not exceed the figure given under “Angular” in the table. If a correction is necessary, be sure to recheck the parallel alignment.

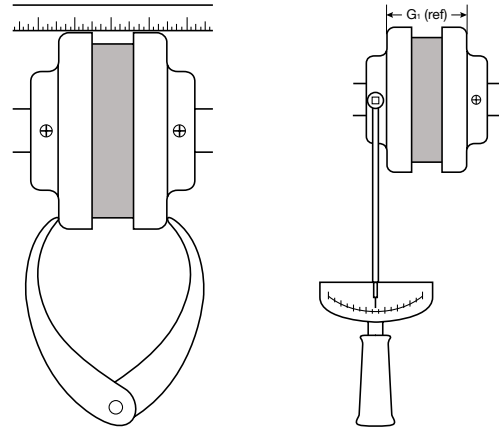

## Maximum RPM and Allowable Misalignment

Sleeve Size	Max RPM	$G_1$	Types JE, JN, JES, JNS, E & N (mm)		*Type H & HS (mm)	
			Parallel	Angular	Parallel	Angular
3	9200	30	.25	.89	...	...
4	7600	38	.25	1.1	...	...
5	7600	49	.38	1.4	...	...
6	6000	60	.38	1.8	.25	.41
7	5250	65	.51	2.1	.31	.51
8	4500	75	.51	2.4	.38	.64
9	3750	89	.64	2.8	.43	.71
10	3600	103	.64	3.2	.51	.81
11	3600	124	.81	3.9	.56	.94
12	2800	145	.81	4.4	.64	1.1
13	2400	170	1.0	5.0	.76	1.3
14	2200	200	1.1	6.2	.89	1.5
16	1500	260	1.6	7.4	...	...

Note: When using a VFD with a centrifugal pump or fan, reduce the above values by 1/2.

\*Type H and HS sleeves should never be used as direct replacements for EPDM or Neoprene sleeves.

**7.** If the coupling employs the two-piece sleeve with wire ring, move the ring into its groove in the center of the sleeve. If necessary, use soapy water and lever the ring with a blunt tool.

**8.** Install coupling guards.

**CAUTION:** Coupling sleeves may be thrown from the coupling assembly with substantial force if subjected to a severe shock load.



# TB Wood's offers a wide range of couplings for industrial applications

For over 70 years, TB Wood's has been designing and manufacturing innovative coupling solutions to meet the requirements for a broad variety of applications spanning many industries. TB Wood's couplings represent the latest in technology, featuring superior design and exceptional quality to ensure long-lasting performance in all types of industrial applications including printing presses, machine tools, cooling tower fans, food processing equipment, pumps, blowers, electric motors, compressors, mixers, and conveyors.



## L-JAW ELASTOMERIC COUPLINGS

Jaw-type elastomeric couplings are an economical, proven solution for general purpose applications. Jaw couplings are easy to install and require no lubrication or maintenance. Four different flexible insert types are available: Buna-N rubber, Urethane, Hytrel™ and Bronze. Jaw couplings are an excellent choice for all light and medium duty general purpose industrial applications. Models available with torque capacities up to 0.70 kNm; 6,228 in.lbs.

*See Catalog P-1686-TBW*



## DURA-FLEX ELASTOMERIC COUPLINGS

Dura-Flex couplings are designed from the ground up using finite element analysis to maximize flex life. Dura-Flex couplings employ a lightweight element that absorbs shock loading and torsional vibration. A flexible polyurethane material offers superior chemical, dynamic and weathering properties. The specially designed "split-in-half flex element" moves stress away from the bond, extending flex life. Dura-Flex couplings are directly interchangeable with similar couplings for fast and easy replacement. Models available with torque capacities up to 4.5 kNm; 39,500 in.lbs.

*See Catalog P-1686-TBW*



## G-FLEX GRID COUPLINGS

State-of-the-art design from Bibby Turboflex, the original grid coupling manufacturer. G-Flex is an all-metal coupling that provides positive protection against the damaging effects of shock loads and vibration. Aluminum horizontal cover (T10), and all-steel vertical cover (T20) designs are available. G-Flex tapered grid couplings are an excellent choice where torsional flexibility and vibration damping are primary concerns. Models available with torque capacities up to 169 kNm; 1,500,000 in.lbs.

*See Catalog P-1686-TBW*



## FORM-FLEX DISC COUPLINGS

Form-Flex metal disc couplings consist of two hubs, a spacer and two high strength carbon or stainless steel flexible discs. Modified and special designs are commonly supplied to meet specific application conditions. Available in carbon steel, stainless steel or with corrosion resistant coatings. Models available with torque capacities up to 270 kNm; 2,400,000 in.lbs.

*See Catalog P-1686-TBW*

## TB Wood's Facilities

### North America

#### USA

440 North Fifth Avenue  
Chambersburg, PA 17201 - USA  
888-829-6637 \* 717-264-7161

*Belted Drives and Elastomeric Couplings*

#### Customer Service

1-888-829-6637 (Press #5)

#### For Application Support

1-888-829-6637 (Press #7)

2000 Clovis Barker Road  
San Marcos, TX 78666 - USA  
1-888-449-9439

*General Purpose Disc Couplings*

#### Customer Service

1-888-449-9439

4970 Joule St  
Reno, NV 89502 - USA  
775-857-1800

#### Canada

9779 45 Ave NW  
Edmonton, AB T6E 5V8 - Canada  
+1 780-439-7979

6305 Danville Road  
Mississauga, ON L5T 2H7 - Canada  
1-800-829-6631

1073 Rue Bégin  
Saint-Laurent, QC H4R 1V8 - Canada  
+1 514-332-4812

#### Mexico

Comisión Federal de Electricidad 850,  
Industrial San Luis,  
San Luis, S.L.P., 78395 - Mexico  
+52 444 137 1500

### Europe

Merchant Drive, Hertford  
Hertfordshire SG13 7BL - England  
+44(0)1992 501900

*Elastomeric Couplings*

## The Brands of Altra Industrial Motion

### Couplings

**Ameridrives**  
[www.ameridrives.com](http://www.ameridrives.com)

**Bibby Turboflex**  
[www.bibbyturboflex.com](http://www.bibbyturboflex.com)

**Guardian Couplings**  
[www.guardiancouplings.com](http://www.guardiancouplings.com)

**Huco**  
[www.huco.com](http://www.huco.com)

**Lamiflex Couplings**  
[www.lamiflexcouplings.com](http://www.lamiflexcouplings.com)

**Stromag**  
[www.stromag.com](http://www.stromag.com)

**TB Wood's**  
[www.tbwoods.com](http://www.tbwoods.com)

### Geared Cam Limit Switches

**Stromag**  
[www.stromag.com](http://www.stromag.com)

### Electric Clutches & Brakes

**Inertia Dynamics**  
[www.idicb.com](http://www.idicb.com)

**Matrix**  
[www.matrix-international.com](http://www.matrix-international.com)

**Stromag**  
[www.stromag.com](http://www.stromag.com)

**Warner Electric**  
[www.warnerelectric.com](http://www.warnerelectric.com)

### Linear Products

**Warner Linear**  
[www.warnerlinear.com](http://www.warnerlinear.com)

### Engineered Bearing Assemblies

**Kilian**  
[www.kilianbearings.com](http://www.kilianbearings.com)

### Heavy Duty Clutches & Brakes

**Industrial Clutch**  
[www.indclutch.com](http://www.indclutch.com)

**Twiflex**  
[www.twiflex.com](http://www.twiflex.com)

**Stromag**  
[www.stromag.com](http://www.stromag.com)

**Svendborg Brakes**  
[www.svendborg-brakes.com](http://www.svendborg-brakes.com)

**Wichita Clutch**  
[www.wichitaclutch.com](http://www.wichitaclutch.com)

### Belted Drives

**TB Wood's**  
[www.tbwoods.com](http://www.tbwoods.com)

### Gearing

**Bauer Gear Motor**  
[www.bauergears.com](http://www.bauergears.com)

**Boston Gear**  
[www.bostongear.com](http://www.bostongear.com)

**Delroyd Worm Gear**  
[www.delroyd.com](http://www.delroyd.com)

**Nuttall Gear**  
[www.nuttallgear.com](http://www.nuttallgear.com)

### Overrunning Clutches

**Formsprag Clutch**  
[www.formsprag.com](http://www.formsprag.com)

**Marland Clutch**  
[www.marland.com](http://www.marland.com)

**Stieber**  
[www.stieberclutch.com](http://www.stieberclutch.com)

Neither the accuracy nor completeness of the information contained in this publication is guaranteed by the company and may be subject to change in its sole discretion. The operating and performance characteristics of these products may vary depending on the application, installation, operating conditions and environmental factors. The company's terms and conditions of sale can be viewed at <http://www.altramotion.com/terms-and-conditions/sales-terms-and-conditions>. These terms and conditions apply to any person who may buy, acquire or use a product referred to herein, including any person who buys from a licensed distributor of these branded products.

©2018 by TB Wood's LLC. All rights reserved. All trademarks in this publication are the sole and exclusive property of TB Wood's LLC or one of its affiliated companies.