

Data Sheet

Electronic Torque Limiting (ETL) Solutions

Series 45 Pumps



The new Series 45 Pressure Compensating/Load Sensing with Electronic Torque Limiting control (PC/LS with ETL), offers the next generation in system performance, efficiency, and innovation. Specifically designed with Tier 4 engines in mind this newly-developed proprietary system allows operators to maximize the total performance potential of their machine.

The Series 45 Electronic Torque Limiting control is designed to be fitted into existing pressure compensated/load sensing or mechanical torque control (MTC) systems. ETL unlocks total system performance potential by allowing infinite adjustment of torque limit settings through the electronic proportional control. PLUS+1[®] Compliant, available with GUIDE programmable software and precompiled electronic controls, this system solution can be quickly and easily implemented into current or new applications.

A flexible, modular product line allows for either the standalone pump to be purchased, or the entire system. Full system integration can be achieved quickly and easily with the Danfoss pre-programmed controllers and GUIDE software blocks. Ready to operate hardware and software significantly reduces machine development and testing time, keeping time to market at a minimum by quickly fitting the system to your specific needs.

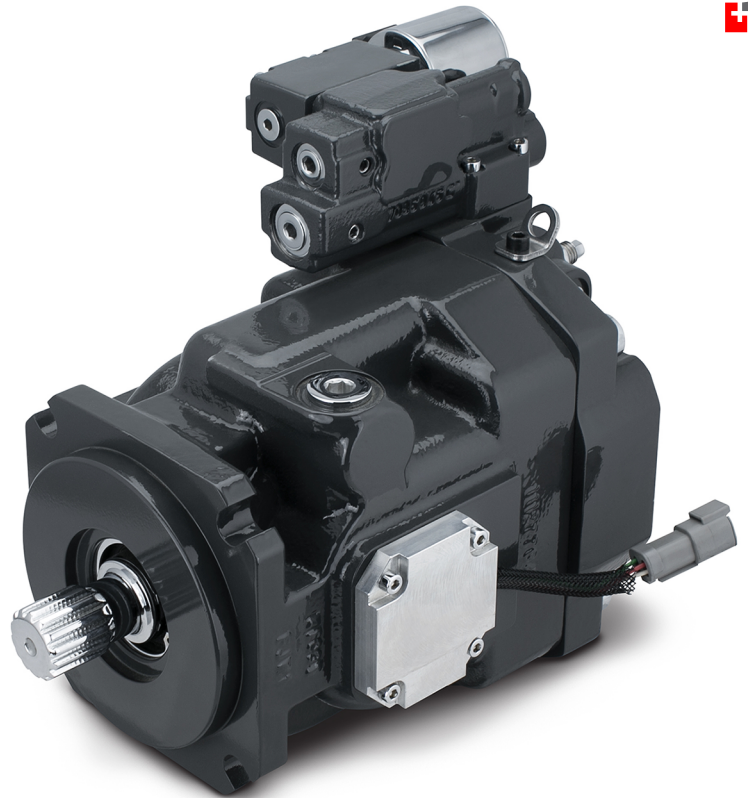

Features

Pressure compensator/load sensing pump with electronic torque limiting control (PC/LS with ETL)

- Available in 12/24 volt configurations
- Normally closed control (NC), removal of signal to control or angle sensor defaults system to regular PC/LS functionality, allows for maximum uptime
- Similar hardware configuration as current electric controls
- Can be easily implemented into PC/LS systems

Angle sensor

- Measures real time swashplate angle (displacement) of the pump with high resolution
- Proven hardware with no interference parts
- Redundant (dual) integrated sensors
 - Improved measurement accuracy
 - Easy sensor fault detection
- PLUS+1[®] compliance block
 - Easy calibration of sensor and diagnostics

- Also available with other common control configurations (PC, PC/LS, RP, ON/OFF)
- IP67 and IP69K Rating with a 4 pin DEUTSCH connector
- Same package size as current electrical controls

Comprehensive technical literature is online at www.danfoss.com

Optional features

- GUIDE Programmable Electronic Torque Limiting Software
 - Optimized ETL software package for plug & perform functionality
 - Available in the work function control library
 - Easy to program software blocks with GUIDE, ideal for adding to existing GUIDE blocks
 - Simple for integration of user inputs, outputs and additional sensors
 - Incorporates Danfoss dual path propel expertise
 - Available for use with other PLUS+1® applications.

Preprogrammed MC12 electronic controller

- Easy to follow service screens for programming
- 12 Pin connector can be added to current machine
- Easy tuning/ calibrations with CANBus integration for plug and perform operation
- Free downloadable and easy to follow simple service tool allows for fast prototyping and improved time to production

Technical specifications

Specification		Unit	Frame J					Frame F		Frame E		
Maximum displacement		cm ³ [in ³]	45 [2.75]	51 [3.11]	60 [3.66]	65 [3.97]	75 [4.58]	74 [4.52]	90 [5.49]	100 [6.1]	130 [7.93]	147 [8.97]
Continuous working pressure		bar [psi]	310 [4500]	310 [4500]	310 [4500]	260 [3770]	260 [3770]	310 [4500]	260 [3770]	310 [4500]	310 [4500]	260 [3770]
Maximum working pressure			400 [5800]	400 [5800]	400 [5800]	350 [5075]	350 [5075]	400 [5800]	350 [5075]	400 [5800]	400 [5800]	350 [5075]
Continuous input speed		min ⁻¹ (rpm)	2800	2700	2600	2500	2400	2400	2200	2450	2200	2100
Theoretical flow		l/min [US gal/min]	126 [33.3]	137.7 [36.4]	156 [41.2]	162 [42.9]	180 [47.5]	177.6 [46.9]	198 [52.3]	245 [64.7]	286 [75.6]	309 [81.6]
Weight*	Axial	kg [lb]	23.1 [51.0]					29.5 [65.0]		52.0 [115.0]		
	Radial		27.3 [60.2]					32.6 [71.9]		26.0 [123.3]		

* Weight values based on CAD geometry without auxiliary flange and PC/LS control

Frame J

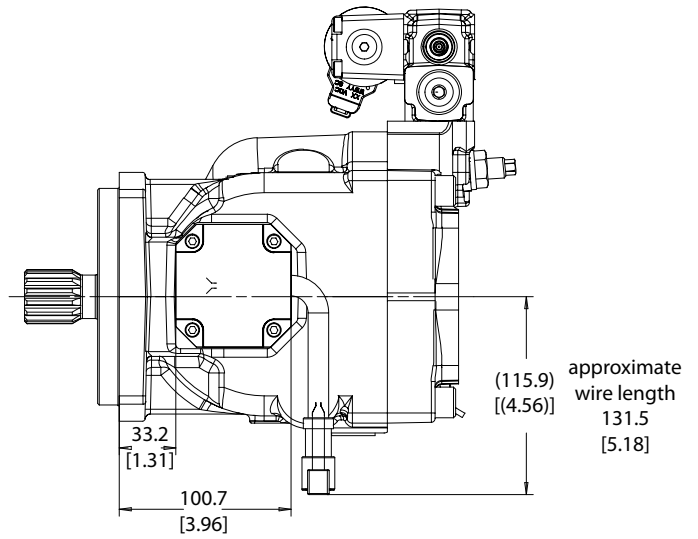
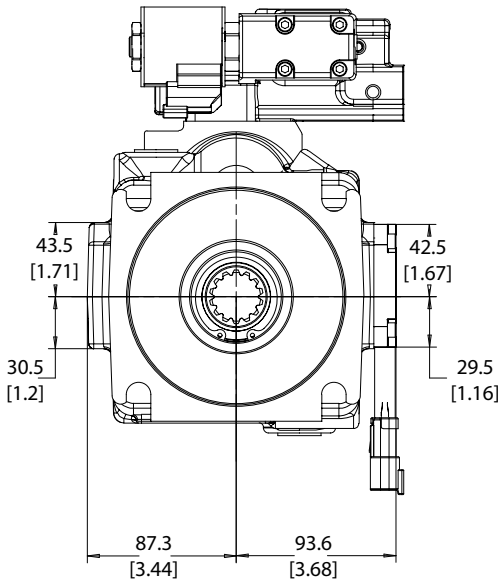

P108777

Frame F

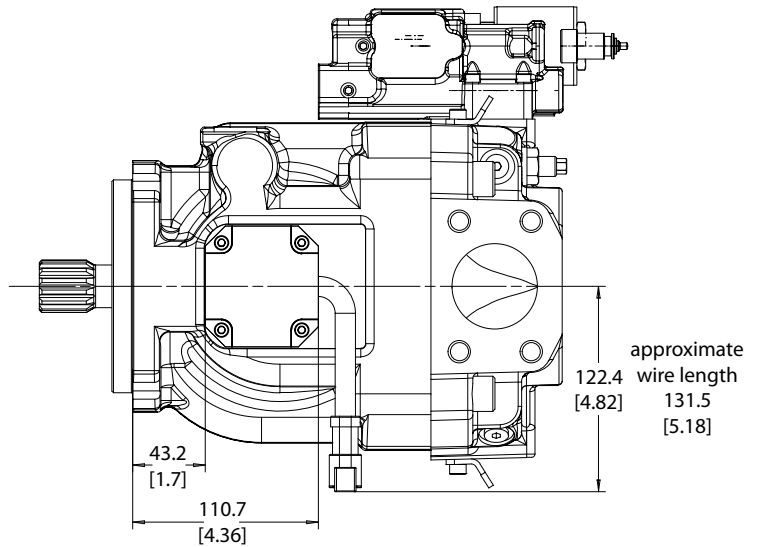
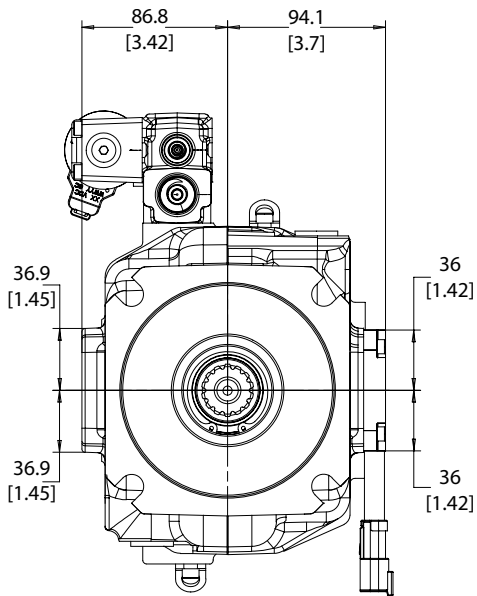

P108778

Frame E

