

**FRENI ELETTRMAGNETICI
A MAGNETE PERMANENTE
Serie PMB-3**

**PERMANENT MAGNET
ELECTROMAGNETIC BRAKES
Model PMB-3**

PRESTAZIONI (24 VCC) • PERFORMANCES (24VDC)

tipo size	coppia torque (Nm)	potenza power (W)	giri/min RPM	tempo inserzione engagement time (ms)	tempo disinserzione disengagement time (ms)	peso weight (kg)
PMB 075-3	5	9,5	10.000	0,008	0,018	0,34
PMB 090-3	10	14	10.000	0,130	0,022	0,59
PMB 115-3	20	18	10.000	0,024	0,030	1,15
PMB 132-3	40	20	10.000	0,028	0,045	2,03
PMB 162-3	80	35	8.000	0,040	0,065	4,5
PMB 190-3	120	37	8.000	0,057	0,090	7

DIMENSIONI (mm) - DIMENSIONS (mm)

tipo size	A	B	C max	D h8	E	F	G	L	N	P H8	Q	R	S
PMB 075-3	56	22	15	75	4,5	2,2	65	29	3,5	24	24	15	0,2
PMB 090-3	70	27	20	90	5,5	2,5	79,5	35	3,5	30	30	20	0,2
PMB 115-3	90	29,2	30	115	6,5	2,5	102	39	3,5	40	41	25	0,2
PMB 132-3	110	33,1	35	132	6,5	3	121	45	5	50	49	30	0,3
PMB 162-3	140	37,2	48	162	6,5	6,5	151	53,5	6,5	70	50	40	0,3
PMB 190-3	160	43,2	45	190	9	7	175	60	7	80	65	40	0,3

NOME PARTICOLARI - PARTS NAME

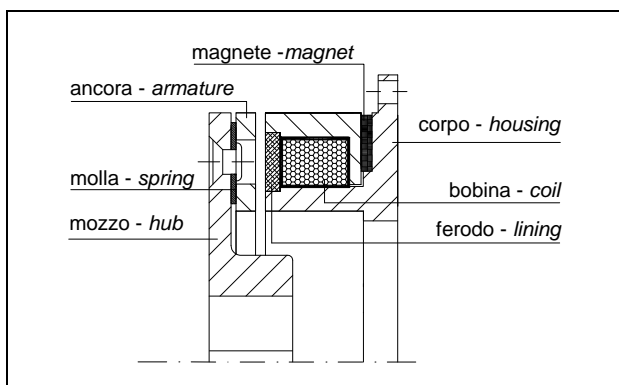

ESEMPIO MONTAGGIO - MOUNTING EXAMPLE

