

INTORQ

setting the standard

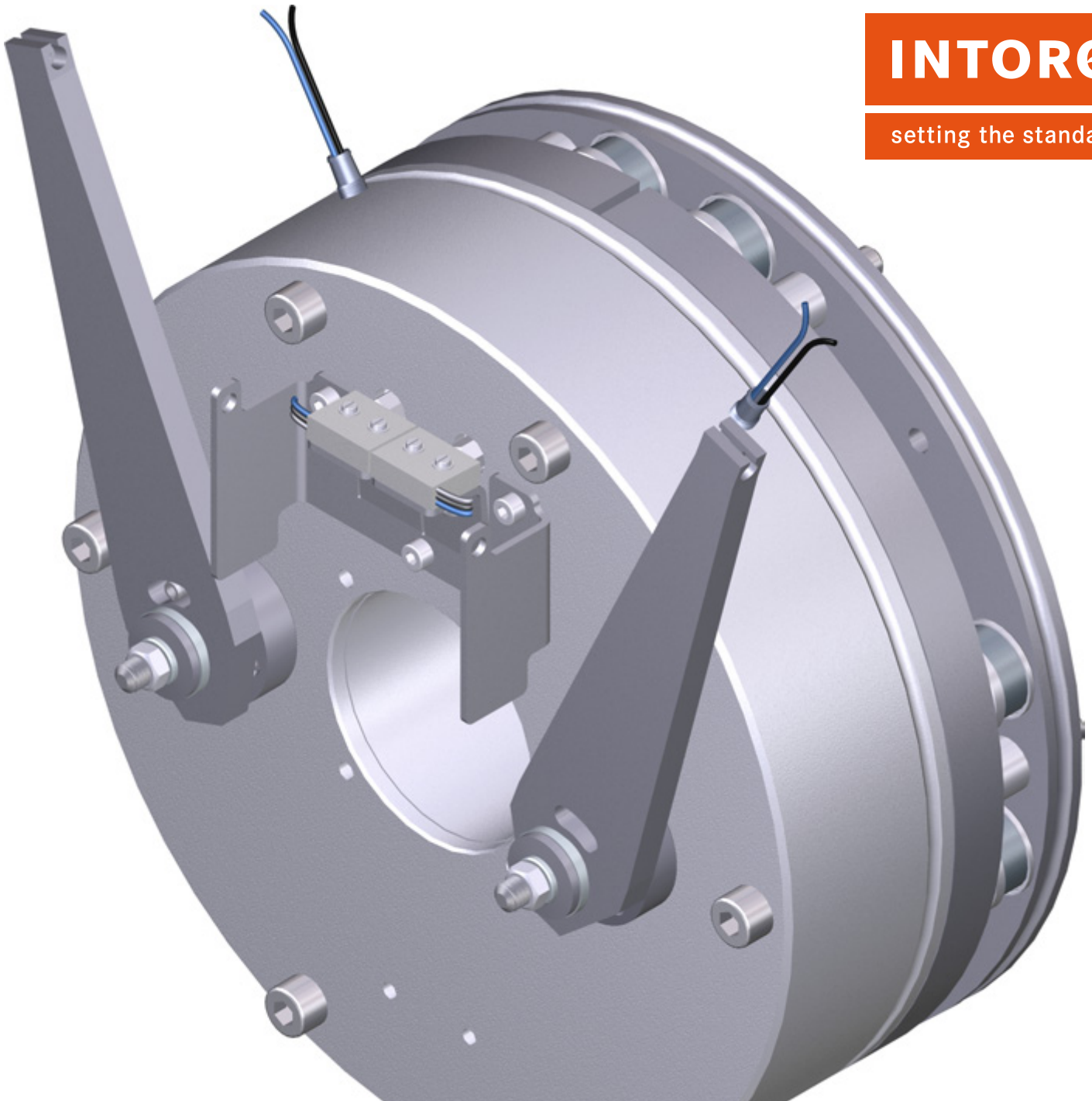

INTORQ BFK464-□□R

Spring-applied brake with electromagnetic release

Translation of the Original Operating Instructions

Document history

Material number	Version			Description
33006446	1.0	09/2017	SC	First edition
33006446	2.0	05/2018	SC	Update of HR and tightening torques
33006446	3.0	10/2019	SC	Migration to ST4

Legal regulations

Liability

- The information, data and notes in these Operating Instructions are up to date at the time of printing. Claims referring to drive systems which have already been supplied cannot be derived from this information, illustrations and descriptions.
- We do not accept any liability for damage and operating interference caused by:
 - inappropriate use
 - unauthorised modifications to the product
 - improper work on or with the drive system
 - operating errors
 - disregarding the documentation

Warranty



Notice

The warranty conditions can be found in the terms of sale and delivery from INTORQ GmbH & Co. KG.

- Warranty claims must be made to INTORQ immediately after the defects or faults are detected.
- The warranty is void in all cases when liability claims cannot be made.

Product key

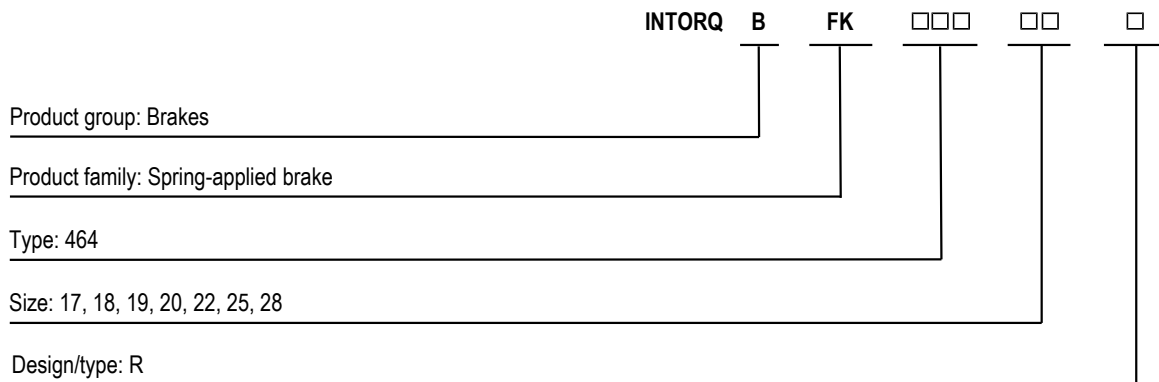

Not coded: Connection voltage, hub bore hole, options

Checking the delivery

After receipt of the delivery, check immediately whether the items delivered match the accompanying papers.

INTORQ does not accept any liability for deficiencies claimed subsequently.

- Claim visible transport damage immediately to the deliverer.
- Claim visible deficiencies or incomplete deliveries immediately to INTORQ GmbH & Co. KG.



NOTICE

Labelling of drive systems and individual components

- Drive systems and components are unambiguously designated by the labelling on their name plates.
- The spring-applied INTORQ brake is also delivered in single modules which can then be put together by the customer according to their requirements. The specifications – particularly the packaging label, name plate and type code – apply to a complete stator.
- The labelling is not included when components are delivered individually.

Contents

Legal regulations	2
Warranty	2
Product key	3
Checking the delivery	3
1 General information	6
1.1 Using these Operating Instructions	6
1.2 Conventions in use.....	6
1.3 Safety instructions and notices	6
1.4 Terminology used.....	7
1.5 Abbreviations used.....	8
2 Safety instructions	10
2.1 General safety instructions.....	10
2.2 Disposal	10
3 Product description	11
3.1 Proper and intended usage.....	11
3.1.1 Standard applications	11
3.2 Layout	11
3.3 Function	13
3.4 Braking and release	13
3.5 Project planning notes.....	13
3.6 Optional configuration	14
3.6.1 Hand-release (optional)	14
3.6.2 Optional micro-switch	14
3.6.3 Optional encapsulated design	14
4 Technical specifications	15
4.1 Possible applications of the INTORQ spring-applied brake	15
4.2 Rated data.....	15
4.3 Switching times	18
4.4 Friction work / operating frequency	20
4.5 Electromagnetic compatibility.....	21
4.6 Emissions.....	21
4.7 Labels on product.....	22
5 Mechanical installation	24

5.1	Design of end shield and shaft.....	24
5.2	Tools	25
5.3	Preparing the installation.....	26
5.4	Installing the hub onto the shaft	27
5.5	Mounting the flange (optional).....	28
5.6	Brake mounting	29
5.7	Cover ring assembly	33
5.8	Installing the hand-release (retrofitting).....	33
6	Electrical installation	37
6.1	Electrical connection	38
6.2	Technical specifications for the micro-switch	39
6.3	Rectifier	40
6.3.1	Bridge-half-wave rectifier for brakes with holding voltage reduction	40
6.3.2	Bridge rectifier for brakes without holding voltage reduction	40
6.3.3	Assignment: Rectifier - Brake size.....	40
6.3.4	Technical specifications.....	41
6.3.5	Permissible current load at ambient temperature	42
7	Commissioning and operation	43
7.1	Function checks before initial commissioning	43
7.1.1	Brake with micro-switch.....	43
7.1.2	Checking the hand-release.....	44
7.2	Commissioning.....	45
7.3	During operation.....	46
8	Maintenance and repair	47
8.1	Wear of spring-applied brakes	47
8.2	Inspections	48
8.2.1	Maintenance intervals.....	48
8.3	Maintenance.....	48
8.3.1	Checking the components	49
8.3.2	Check the rotor thickness	49
8.3.3	Checking the air gap.....	50
8.3.4	Release / voltage.....	50
8.3.5	Replace rotor	51
8.4	Spare parts list	52
9	Troubleshooting and fault elimination.....	53



1 General information

1.1 Using these Operating Instructions

- These Operating Instructions will help you to work safely with the spring-applied brake with electro-magnetic release. They contain safety instructions that must be followed.
- All persons working on or with electromagnetically released spring-applied brakes must have the Operating Instructions available and observe the information and notes relevant for them.
- The Operating Instructions must always be in a complete and perfectly readable condition.

1.2 Conventions in use



This document uses the following styles to distinguish between different types of information:

Spelling of numbers	Decimal separator	Point	The decimal point is always used. For example: 1234.56
Page reference	Underscore, orange		Reference to another page with additional information For example: <u>Using these Operating Instructions, Page 6</u>
Symbols	Wildcard	□	Wildcard (placeholder) for options or selection details For example: BFK464-R-□□ = BFK464-R-10
	Notice		Important notice about ensuring smooth operations or other key information.



1.3 Safety instructions and notices



The following icons and signal words are used in this document to indicate dangers and important safety information:



Structure of safety notices:

	 CAUTION
	<p>Icon Indicates the type of danger</p> <p>Signal word Characterizes the type and severity of danger.</p> <p>Notice text Describes the danger.</p> <p>Possible causes List of possible consequences if the safety notices are disregarded.</p> <p>Protective measures List of protective measures required to avoid the danger.</p>

Danger level

	 DANGER
	<p>DANGER indicates a hazardous situation which, if not avoided, <i>will</i> result in death or serious injury.</p>

	 WARNING
	<p>WARNING indicates a potentially hazardous situation which, if not avoided, <i>could</i> result in death or serious injury.</p>

	 CAUTION
	<p>CAUTION indicates a hazardous situation which, if not avoided, could result in minor or moderate injury.</p>

	NOTICE
	<p>Notice about a harmful situation with possible consequences: the product itself or surrounding objects could be damaged.</p>

1.4 Terminology used

Term	In the following text used for
Spring-applied brake	Spring-applied brake with electromagnetic release
Drive system	Drive systems with spring-applied brakes and other drive components

1.5 Abbreviations used

Letter symbol	Unit	Designation
F_R	N	Rated frictional force
I	A	Current
I_H	A	Holding current, at 20 °C and holding voltage
I_L	A	Release current, at 20 °C and release voltage
I_N	A	Rated current, at 20 °C and rated voltage
M_A	Nm	Tightening torque of fastening screws
M_{dyn}	Nm	Braking torque at a constant speed of rotation
M_K	Nm	Rated torque of the brake, rated value at a relative speed of rotation of 100 rpm
n_{max}	rpm	Maximum occurring speed of rotation during the slipping time t_3
P_H	W	Coil power during holding, after voltage change-over and 20 °C
P_L	W	Coil power during release, before voltage change-over and 20 °C
P_N	W	Rated coil power, at rated voltage and 20 °C
Q	J	Quantity of heat/energy
Q_E	J	Max. permissible friction energy for one-time switching, thermal parameter of the brake
Q_R	J	Braking energy, friction energy
Q_{Smax}	J	Maximally permissible friction energy for cyclic switching, depending on the operating frequency
R_m	N/mm ²	Tensile strength
R_N	Ohms	Rated coil resistance at 20 °C
R_z	µm	Averaged surface roughness
S_n	1/h	Operating frequency: the number of switching operations evenly spread over the time unit
S_{hue}	1/h	Transition operating frequency, thermal parameter of the brake
S_{nmax}	1/h	Maximum permissible operating frequency, depending on the friction energy per switching operation
s_L	mm	Air gap: the lift of the armature plate while the brake is switched
s_{LN}	mm	Rated air gap
s_{Lmin}	mm	Minimum air gap
s_{Lmax}	mm	Maximum air gap
s_{HL}	mm	Air gap for hand-release
t_1	ms	Engagement time, sum of the delay time and braking torque: rise time $t_1 = t_{11} + t_{12}$
t_2	ms	Disengagement time, time from switching the stator until reaching 0.1 M_{dyn}

Letter symbol	Unit	Designation
t_3	ms	Slipping time, operation time of the brake (according to t_{11}) until standstill
t_{11}	ms	Delay during engagement (time from switching off the supply voltage to the beginning of the torque rise)
t_{12}	ms	Rise time of the braking torque, time from the start of torque rise until reaching the braking torque
t_{ue}	s	Over-excitation period
U	V	Voltage
U_H	V DC	Holding voltage, after voltage change-over
U_L	V DC	Release voltage, before voltage change-over
U_N	V DC	Rated coil voltage; in the case of brakes requiring a voltage change-over, U_N equals U_L

2 Safety instructions

2.1 General safety instructions

- Never operate INTORQ components when you notice they are damaged.
- Never make any technical changes to INTORQ components.
- Never operate INTORQ components when they are incompletely mounted or incompletely connected.
- Never operate INTORQ components without their required covers.
- Only use accessories that have been approved by INTORQ.
- Only use original spare parts from the manufacturer.

Keep the following in mind during the initial commissioning and during operation:

- Depending on the degree of protection, INTORQ components may have both live (voltage carrying), moving and rotating parts. Such components require the appropriate safety mechanisms.
- Surfaces can become hot during operation. Take the appropriate safety measures (to ensure contact/touch protection).
- Follow all specifications and information found in the Operating Instructions and the corresponding documentation. These must be followed to maintain safe, trouble-free operations and to achieve the specified product characteristics.
- The installation, maintenance and operation of INTORQ components may only be carried out by qualified personnel. According to IEC 60364 and CENELEC HD 384, skilled personnel must be qualified in the following areas:
 - Familiarity and experience with the installation, assembly, commissioning and operation of the product.
 - Specialist qualifications for the specific field of activity.
 - Skilled personnel must know and apply all regulations for the prevention of accidents, directives, and laws relevant on site.

2.2 Disposal

The INTORQ components are made of various differing materials.

- Recycle metals and plastics.
- Ensure professional disposal of assembled PCBs according to the applicable environmental regulations.

3 Product description

3.1 Proper and intended usage

3.1.1 Standard applications

INTORQ components are intended for use in machinery and facilities. They may only be used for purposes as specified in the order and confirmed by INTORQ. The INTORQ components may only be operated under the conditions specified in these Operating Instructions. They may never be operated beyond their specified performance limits. The technical specifications (refer to Technical specifications, Page 15) must be followed to comply with the proper and intended usage. Any other usage is consider improper and prohibited.

3.2 Layout

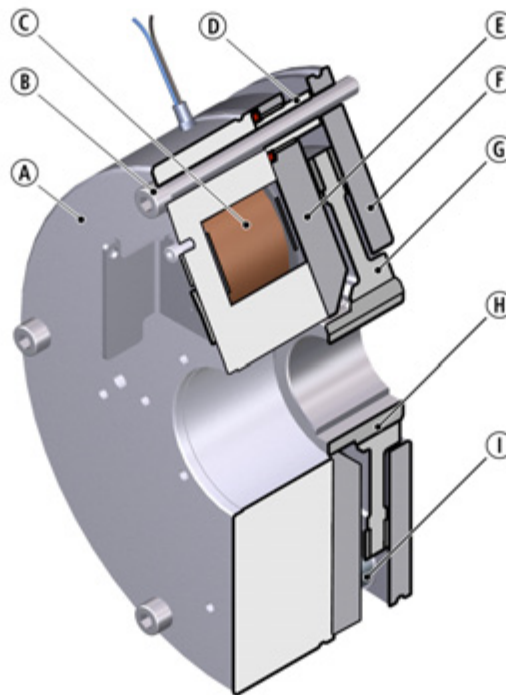

Fig. 1: Layout of an INTORQ BFK464-□R spring-applied brake Complete stator + rotor + flange

- | | | |
|----------|-------------------------|---------------------|
| Ⓐ Stator | Ⓑ Socket-head cap screw | Ⓒ Coil |
| Ⓓ Sleeve | Ⓔ Armature plate | Ⓕ Flange (optional) |
| Ⓔ Rotor | Ⓕ Hub (optional) | Ⓖ Noise reducer |

The BFK464-R spring-applied brake is a single-disk brake with two friction surfaces. The braking torque is applied through two separate braking circuits, both electrical and mechanical, via several compression springs in the form of friction locking. The brake circuits are released electromagnetically. Due to its division into two brake circuits, the brake is particularly suitable for applications such as lift systems and stage/platform technology. The brake can be selected based on the rated torque for one brake circuit. The second brake circuit meets the requirement for redundancy (refer to Rated data for coil power, Page 16).

The division of the brake circuits is done using a two-part armature disk with the associated compression springs and electromagnetic coils. Each brake circuit can be operated individually due to the separate supply lines for each stator and armature plate (siehe).

Each brake circuit has a micro-switch which monitors the switching state of the spring-applied brake. Using the associated switching device, the supply voltage (AC voltage) is rectified and, when the brake is released, lowered after a short period of time. This results in a reduction of the average electrical power of the brake.

The BFK464 spring-applied brake (with the high rated torque for the respective size) is designed for a maximum duty cycle of 60% with holding current reduction. The brakes with the lower rated torques are suitable for a maximum 60% duty cycle with no holding current reduction. The permissible operating frequency for both versions in each size is 180 1/h (with a short-term maximum of 240 1/h).

Size	Rated torque M_k [Nm]	EC-type examination certificate Directive 2014/33/EC
17R	2 x 75	EU-BD 1051
	2 x 150	
18R	2 x 170	EU-BD 1056
	2 x 280	
19R	2 x 210	EU-BD 1055
	2 x 350	
20R	2 x 280	EU-BD 1034
	2 x 450	
22R	2 x 360	EU-BD 1054
	2 x 600	
25R	2 x 540	EU-BD 1053
	2 x 900	
28R	2 x 720	EU-BD 1052
	2 x 1200	

3.3 Function

This brake is an electrically releasable spring-applied brake with a rotating brake disc (rotor) that is equipped on both sides with friction linings. In its de-energised state, the rotor is clamped with braking force applied by pressure springs between the armature plate and a counter friction surface. This corresponds to a fail-safe functionality.

The brake torque applied to the rotor is transferred to the input shaft via a hub that has axial gear teeth.

The brake can be used as a holding brake, as an operating brake, and as an emergency stop brake for high speeds.

The asbestos-free friction linings ensure a safe braking torque and low wear.

To release the brake, the armature plate is released electromagnetically from the rotor. The rotor, shifted axially and balanced by the spring force, can rotate freely.

3.4 Braking and release

During the braking procedure, the inner and outer springs use the armature plate to press the rotor (which can be shifted axially on the hub) against the friction surface. The asbestos-free friction linings ensure high braking torque and low wear. The braking torque is transmitted between the hub and the rotor via gear teeth.

When the brakes are applied, an air gap (s_L) is present between the stator and the armature plate. To release the brake, the coil of the stator is energised with the DC voltage provided. The resulting magnetic flux works against the spring force to draw the armature plate to the stator. This releases the rotor from the spring force and allows it to rotate freely.

3.5 Project planning notes

- When designing a brake for specific applications, torque tolerances, the limiting speeds of the rotors, the thermal resistance of the brake, and the effect of environmental influences must all be taken into account.
- The brakes are dimensioned in such a way that the specified rated torques are reached safely after a short run-in process.
- However, as the organic friction linings used do not all have identical properties and because environmental conditions can vary, deviations from the specified braking torques are possible. These must be taken into account in the form of appropriate dimensioning tolerances. Increased breakaway torque is common in particular after long downtimes in humid environments where temperatures vary.
- If the brake is used as a pure holding brake without dynamic load, the friction lining must be reactivated regularly.

3.6 Optional configuration

3.6.1 Hand-release (optional)

To temporarily release the brake when there is no electricity available, a hand-release function is available as an option. The hand-release function can be retrofitted.

3.6.2 Optional micro-switch

The micro-switch is used for the release monitoring or for wear monitoring. The user is responsible for arranging the electrical connection for this optional micro-switch.

- Usage for the (air) release monitoring: The motor will start only after the brake has been released. This enables the micro-switch to monitor for errors (e.g. when the motor does not start because of a defective rectifier, if there are broken connection cables, defective coils, or an excessive air gap).
- Usage for monitoring wear: The brake and motor are not supplied with power when the air gap is too large.

3.6.3 Optional encapsulated design

This design not only prevents the penetration of spray water and dust, but also the spreading of abrasion particles outside the brake. This is achieved by the following enclosures:

- A cover ring over the armature plate and rotor.

4 Technical specifications

4.1 Possible applications of the INTORQ spring-applied brake

- Degree of protection:
 - The brake is designed for operation under the environmental conditions that apply to IP54 protection. Because of the numerous possibilities of using the brake, it is still necessary to check the functionality of all mechanical components under the corresponding operating conditions.
- Ambient temperature:
 - -20 °C to +40 °C (Standard)

4.2 Rated data

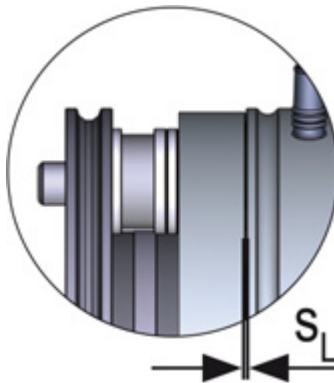

Fig. 2: Air gap measurement

Size	Air gap		Permissible wear distance [mm]	Rotor thickness		Mass of stator m
	$s_{LN}^{+0.06/-0.08}$	s_{Lmax}		Min.	Max.	
	[mm]	[mm]		[mm]	[mm]	[kg]
17R	0.4	0.6	0.2	12.7	13.0	12.4
18R						19.2
19R						22.5
20R						26.5
22R						31.0
25R						41.5
28R	0.5	0.8	0.3	12.6		55.5

Tab. 1: Rated data for air gap specifications

Size	Screw hole circle		Fastening screws DIN 912		Minimum thread depth		Tightening torque M_A	
	Diameter	Thread	without flange	with flange	without flange	with flange ¹⁾	without flange	with flange ¹⁾
	[mm]		[mm]	[mm]	[mm]	[mm]	[Nm]	[Nm]
17R	176	M8	6 x M8x85	6 x M8x95	13.0	12.0	24.6	24.6
18R	212		6 x M8x95	6 x M8x105 ¹⁾				30.4
19R	220	M10	6 x M10x100	6 x M10x110	16.0	15.0	48.0	48.0
20R	233		6 x M10x110	6 x M10x120 ¹⁾	21.0	20.0		66.5
22R	252							
25R	282	M12	6 x M12x110	6 x M12x130 ¹⁾	18.0	25.0	84.0	104.7
28R	314	M16	6 x M16x130	6 x M16x140	30.0	27.5	206.0	206.0

Tab. 2: Rated data for the screw set for brake mounting

¹⁾ Bolt fastening class 10.9 with washers in accordance with ISO 7089--300HV-A2C

CAUTION

- The screws for the different brake attachment variants have different strength grades and may have special surface coatings. In order to guarantee a secure screw connection, use **ONLY** the proper screws from INTORQ!
- It is very important to comply with the minimum thread depth of the end shield (refer to [Rated data for the screw set for brake mounting, Page 16](#)).
- If the required thread depth is not maintained, the fastening screws may run onto the thread root. This has the effect that the required pre-load force is no longer established – the brake is no longer securely fastened!

Size	Rated torque ¹⁾ M_K [Nm]	Voltage		Power ²⁾		Coil resistance $R_N^{\pm 5\%}$ [Ω]	Current ³⁾ I_L [A]
		Release $\pm 10\%$	Hold $\pm 10\%$	Brake release	Brake hold		
		U_L [V DC]	U_H [V DC]	P_N [W]	P_H [W]		
17R	2 x 75	205	205	2 x 75	2 x 75	2 x 560	2 x 0.37
		103	103			2 x 142	2 x 0.73
	2 x 150	205	103	2 x 200	2 x 50	2 x 210	2 x 0.98
		103	51.5			2 x 52	2 x 1.99
18R	2 x 170	205	205	2 x 88	2 x 88	2 x 478	2 x 0.43
		103	103			2 x 121	2 x 0.85
	2 x 280	205	103	2 x 230	2 x 57.5	2 x 183	2 x 1.12
		103	51.5			2 x 46	2 x 2.23

Size	Rated torque ¹⁾ M_K [Nm]	Voltage		Power ²⁾		Coil resistance $R_N^{\pm 5\%}$ [Ω]	Current ³⁾ I_L [A]
		Release $\pm 10\%$	Hold $\pm 10\%$	Brake release	Brake hold		
		U_L	U_H	P_N	P_H		
19R	2 x 210	205	205	2 x 95	2 x 95	2 x 442	2 x 0.46
		103	103			2 x 112	2 x 0.92
	2 x 350	205	103	2 x 245	2 x 61	2 x 172	2 x 1.20
		103	51.5			2 x 43	2 x 2.38
20R	2 x 280	205	205	2 x 100	2 x 100	2 x 420	2 x 0.49
		103	103			2 x 106	2 x 0.97
	2 x 450	205	103	2 x 270	2 x 67.5	2 x 156	2 x 1.32
		103	51.5			2 x 39	2 x 2.62
22R	2 x 360	205	205	2 x 110	2 x 110	2 x 382	2 x 0.54
		103	103			2 x 96	2 x 1.07
	2 x 600	205	103	2 x 285	2 x 71	2 x 147	2 x 1.39
		103	51.5			2 x 37	2 x 2.77
25R	2 x 540	205	205	2 x 120	2 x 120	2 x 350	2 x 0.59
		103	103			2 x 88	2 x 1.17
	2 x 900	205	103	2 x 300	2 x 75	2 x 140	2 x 1.46
		103	51.5			2 x 35	2 x 2.91
28R	2 x 720	205	205	2 x 160	2 x 160	2 x 262	2 x 0.78
		103	103			2 x 66	2 x 1.55
	2 x 1200	205	103	2 x 400	2 x 100	2 x 106	2 x 1.95
		103	51.5			2 x 26	2 x 3.88

Tab. 3: Rated data for coil power

¹⁾ Minimum braking torque with run-in friction pairs at $\Delta n = 100$ rpm

²⁾ Power at 20 °C

³⁾ Current at 20 °C during brake release

4.3 Switching times

The operating times listed here are guide values which apply to DC switching with rated air gap s_{LN} , warm coil and standard characteristic torque. The operating times given are mean values and subject to variations. The engagement time t_1 is approximately 8 to 10 times longer for AC switching. ...

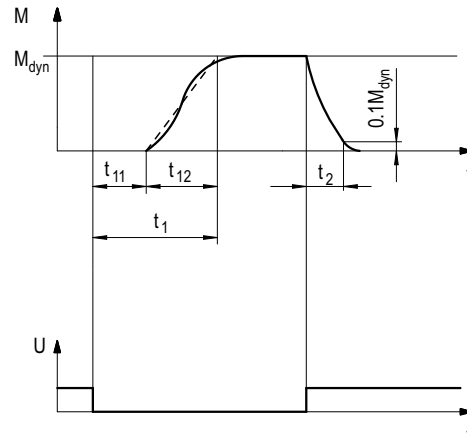

Fig. 3: Operating/switching times of the spring-applied brakes

- t_1 Engagement time
- t_2 Disengagement time (up to $M = 0.1 M_{dyn}$)
- M_{dyn} Braking torque at a constant speed of rotation
- t_{11} Delay time during engagement
- t_{12} Rise time of the braking torque
- U Voltage

Size	Rated torque M_K [Nm]	Max. permissible switching energy Q_E [J]	Transitional operating frequency S_{hue} [1/h]	Switching times						Max. speed n_{max}^5 [rpm]	
				DC-side engagement				Disengaging			
				$t_{10}^{1)}$ [ms]	$t_{90}^{1)}$ [ms]	$t_{11.AC}^{2)}$ [ms]	$t_{1.AC}^{2)}$ [ms]	$t_{2ab@s_{LN}}^{3)}$ [ms]	$t_{2ab@s_{Lmax}}^{3)}$ [ms]		
17R	2 x 75	42000	25	68	140	275	530	180	339	900	
17R ⁴⁾	2 x 150			39	77	150	315	134	194		
18R	2 x 170	60000	20	86	172	350	800	234	365		
18R ⁴⁾	2 x 280			55	100	225	615	169	265		
19R	2 x 210	68000	19	100	182	425	1025	240	435		
19R ⁴⁾	2 x 350			53	116	225	735	180	310		
20R	2 x 280	80000	19	87	175	350	1100	334	700		
20R ⁴⁾	2 x 450			49	106	200	830	216	390		
22R	2 x 360	90000	18	95	207	350	1160	323	622		750
22R ⁴⁾	2 x 600			53	125	200	890	234	400		
25R	2 x 540	120000	15	130	250	450	1410	362	800	700	
25R ⁴⁾	2 x 900			73	153	250	970	287	480	600	

Size	Rated torque	Max. permissible switching energy	Transitional operating frequency	Switching times						Max. speed
				DC-side engagement				Disengaging		
	M_K	Q_E	S_{hue}	$t_{10}^{1)}$	$t_{90}^{1)}$	$t_{11.AC}^{2)}$	$t_{1.AC}^{2)}$	$t_{2ab@S_{LN}^{3)}$	$t_{2ab@S_{Lmax}^{3)}$	$n_{max}^{5)}$
[Nm]	[J]	[1/h]	[ms]	[ms]	[ms]	[ms]	[ms]	[ms]	[rpm]	
28R	2 x 720	180000	14	141	277	500	1490	402	750	600
28R ⁴⁾	2 x 1200			69	176	300	1050	298	500	500

Tab. 4: Switching energy - operating frequency - operating times

- ¹⁾ Operating/switching times, according to type examination certificate, are based on the rated torque. $t_{50} = (t_{10} + t_{90}) / 2$.
- ²⁾ Operating times refer to steady braking torque.
- ³⁾ Venting times under unfavorable conditions (240 switching operations per hour, 60% DC, 40 °C ambient temperature).
- ⁴⁾ Brake supplied with over-excitation (release voltage / holding voltage = 2/1).
- ⁵⁾ Max. speed according to type examination certificate (for higher speeds, please first contact the manufacturer).

Engagement time

The transition from a brake-torque-free state to a holding-braking torque is not free of time lags.

For emergency braking, short engagement times for the brake are absolutely essential. The DC-side switching in connection with a suitable spark suppressor must therefore be provided.

Engagement time for AC-side switching: The engagement time is significantly longer (approx. 5 times longer).

	NOTICE
	Connect the spark suppressors in parallel to the contact. If this is not admissible for safety reasons (e.g. with hoists and lifts), the spark suppressor can also be connected in parallel to the brake coil.

- If the drive system is operated with a frequency inverter so that the brake will not be de-energized before the motor is at standstill, AC switching is also possible (not applicable to emergency braking).
- The specified engagement times are valid for DC switching with a spark suppressor.
 - Circuit proposals: refer to DC switching at mains – fast engagement.



Notice

Spark suppressors are available for the rated voltages.

Disengagement time

The disengagement time is the same for DC-side and AC-side switching. The specified disengagement times always refer to control using INTORQ rectifiers and rated voltage.

4.4 Friction work / operating frequency

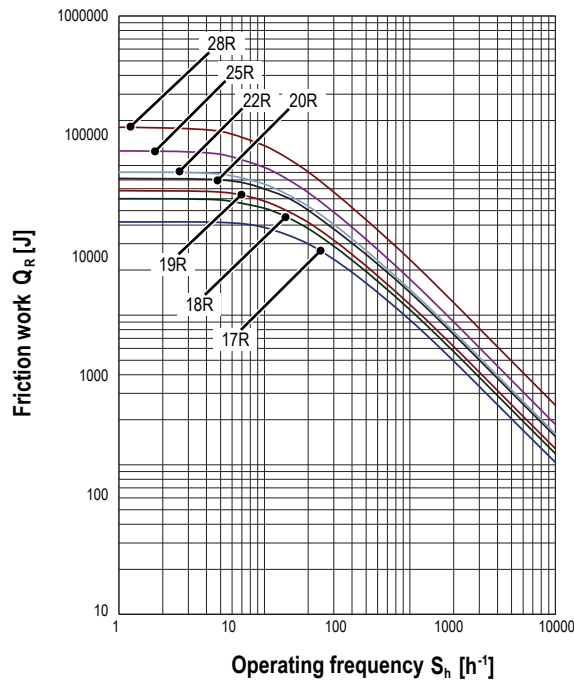

Fig. 4: Friction work as a function of the operating frequency

$$S_{hmax} = \frac{-S_{hue}}{\ln\left(1 - \frac{Q_R}{Q_E}\right)} \qquad Q_{hmax} = Q_E \left(1 - e^{\frac{-S_{hue}}{S_h}}\right)$$

The permissible operating frequency S_{hmax} depends on the amount of heat Q_R (refer to [Figure Friction work / operating frequency, Page 20](#)). At a pre-set operating frequency S_h , the permissible amount of heat is Q_{Smax} .



Notice

With high speeds of rotation and switching energy, the wear increases, because very high temperatures occur at the friction surfaces for a short time.

4.5 Electromagnetic compatibility



Notice

The user must ensure compliance with EMC Directive 2014/30/EC using appropriate controls and switching devices.

NOTICE	
	<p>If an INTORQ rectifier is used for the DC switching of the spring-applied brake and if the operating frequency exceeds five switching operations per minute, the use of a mains filter is required.</p> <p>If the spring-applied brake uses a rectifier of another manufacturer for the switching, it may become necessary to connect a spark suppressor in parallel with the AC voltage. Spark suppressors are available on request, depending on the coil voltage.</p>

4.6 Emissions

Heat

Since the brake converts kinetic energy as well as mechanical and electrical energy into heat, the surface temperature varies considerably, depending on the operating conditions and possible heat dissipation. Under unfavourable conditions, the surface temperature can reach 130 °C.

Noise

The loudness of the switching noise during engaging and disengaging depends on the air gap "s_L" and the brake size.

Depending on the natural oscillation after installation, operating conditions and the state of the friction surfaces, the brake may squeak during braking.

Others

The abrasion of the friction parts produces dust.

4.7 Labels on product

There is a packaging label on the package. The name plate is glued to the outer surface of the brake.

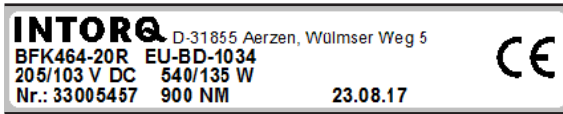

Fig. 5: Name plate

INTORQ	Manufacturer
BFK464-20-R	Type (refer to Product key, Page 3)
EU-BD-1934	EC-type examination certificate
205/103 V DC	Rated voltage
540/135 W	Rated power
33005457	ID number
900 NM	Rated torque
23.08.17	Packaging date
	CE mark



Fig. 6: Packaging label



INTORQ	Manufacturer
33005457	ID number
BFK464-20R	Type (refer to Product key, Page 3)
	Bar code
SPRING-APPLIED BRAKE	Designation of the product family
205/103 V DC	Rated voltages of both braking circuits
900 NM	Rated torque
Pieces	Qty. per box
540/135 W	Rated powers for both braking circuits
28.07.17	Packaging date
Anti-rust packaging: keep friction surface free of grease!	Addition
	CE mark



Fig. 7: Product traceability sticker

BFK464-20-R	Type (refer to Product key, Page 3)
33005457	ID number
G1708200000000000	Serial number
	QR code

5 Mechanical installation

This chapter provides step-by-step instructions for the installation.

Important notes

	NOTICE
	The toothed hub and screws must not be lubricated with grease or oil.

5.1 Design of end shield and shaft





- Comply with the specified minimum requirements regarding the end shield and the shaft to ensure a correct function of the brake.
- The diameter of the shaft shoulder must not be greater than the tooth root diameter of the hub.
- The form and position tolerances apply only to the materials mentioned. Consult with INTORQ before using other materials; INTORQ's written confirmation is required for such usage.
- The brake flange must be supported by the end shield across the full surface.
- Keep the end shield free from grease or oil.



Minimum requirements of the end shield

Size	Material	Roughness	Run-out	Levelness
			[mm]	[mm]
17R ... 28R	S235JR; C15; EN-GJL-250	Rz10 ... Rz16	< 0.1	< 0.1

Tab. 5: End shield as counter friction surface

5.2 Tools

Size	Torque wrench Insert for hexagonal socket (Allen) screws		Open-end wrench Width across flats	Socket wrench for transport safety bolts
				
	Measuring range	Wrench width	Width across flats	Width across flats
	[Nm]	[mm]	[mm]	[mm]
17R	20 to 100	6	10	5
18R				
19R		8	13	6
20R				
22R				
25R	10	17	8	
28R	40 to 250	14	19	10

Multimeter	Caliper gage	Feeler gage
		

5.3 Preparing the installation

1. Remove the packaging from the spring-applied brake and dispose of it properly.
2. Check the delivery for completeness.
3. Check the name plate specifications (especially rated voltage)!

**Notice**

We provide a lifting mechanism for hooking onto a hoist to make it easier to remove the brake from its shipping container.

For sizes 22, 25 and 28, there is also an M10 thread (not shown) located in the middle between the connecting cables of the two brake circuits.

Make sure that the cylindrical dampers on the armature plate are not damaged when you are lifting the brake using an eyebolt.



Fig. 8: Lifting mechanism for hooking onto a hoist

5.4 Installing the hub onto the shaft



Notice

The customer is responsible for dimensioning the shaft-hub connection. Make sure that the supporting length of the key is identical to the length of the hub.

	NOTICE
	If you are using the spring-applied brake for reverse operations, glue the hub to the shaft.

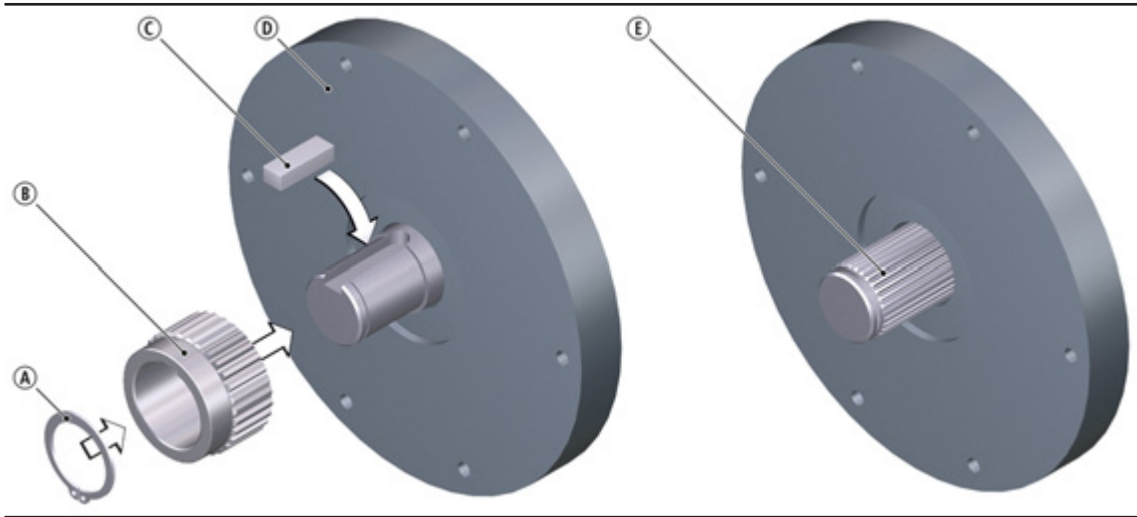

Fig. 9: Installing the hub onto the shaft

- | | | |
|--------------|----------------------------|---------------------------------|
| Ⓐ Circlip | Ⓑ Hub (optional) | Ⓒ Key shape B (angular version) |
| Ⓓ End shield | Ⓔ Toothed shaft (optional) | |

1. Insert the key into the shaft.
2. Press the hub with a moderate amount of force to the shaft.
3. Secure the hub against axial displacement (for example, by using a circlip).

5.5 Mounting the flange (optional)

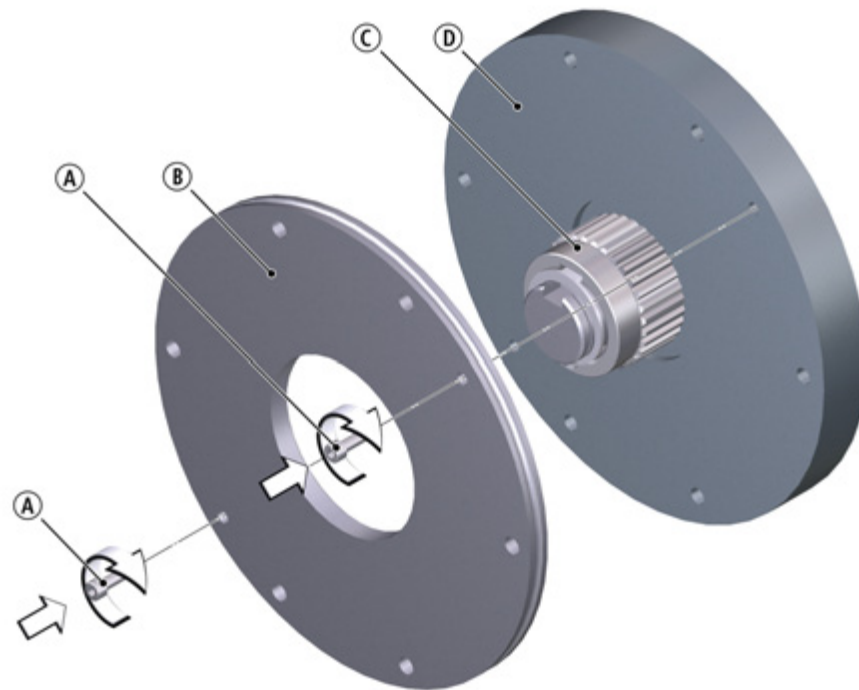

Fig. 10: Mounting the flange

- Ⓐ Socket-head cap screw Ⓑ Flange (optional) Ⓒ Hub or shaft with teeth (optional)
Ⓓ End shield

1. Hold the flange to the end shield. Place the chamfer at the inner diameter on the side of the end shield.
2. Align the through holes in the flange to the threads of the fastening bore holes.

5.6 Brake mounting



Notice

Here, the mounting of the brake is shown in the version with the optional flange and toothed shaft

NOTICE	
	<p>Only in the case of rotors with mounting paste on their gear teeth:</p> <ul style="list-style-type: none"> ■ Remove cover films from both front ends of the rotor. ■ Protect friction surfaces against contact with mounting paste! ■ After the mounting, excessive mounting paste must be removed properly!

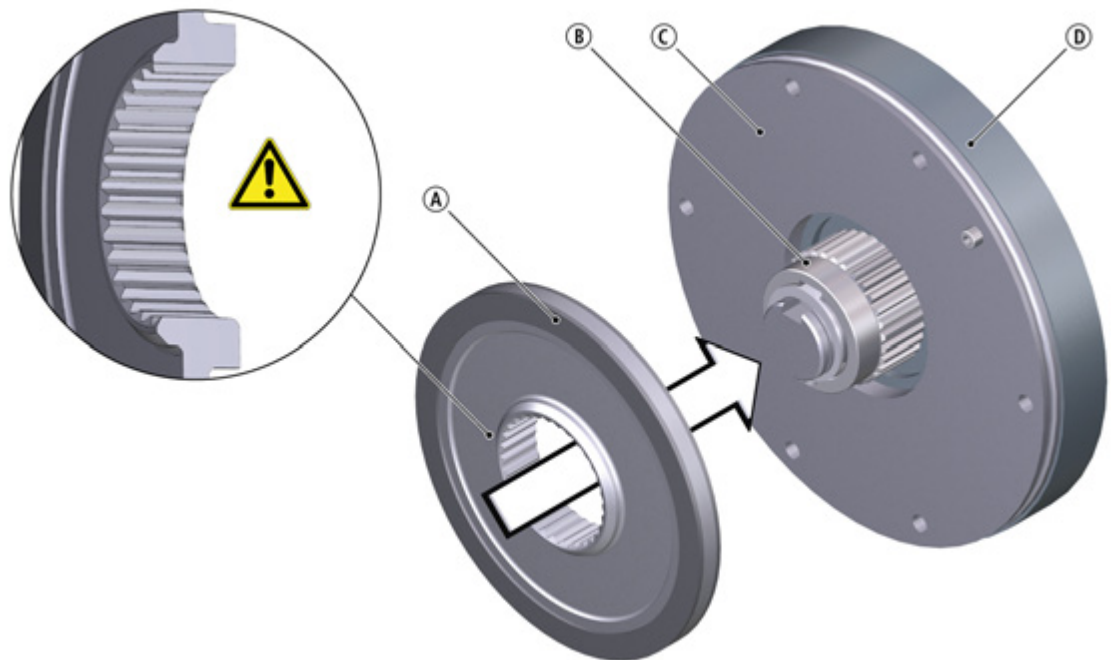

Fig. 11: Assembly of the rotor

- Ⓐ Rotor
- Ⓑ Hub or shaft with teeth (optional)
- Ⓒ Flange (optional)
- Ⓓ End shield

	<p>⚠ CAUTION</p>
<p>Note the illustration showing the chamfer of the rotor!</p>	

1. Push the rotor onto the shaft and check that it can be moved by hand.

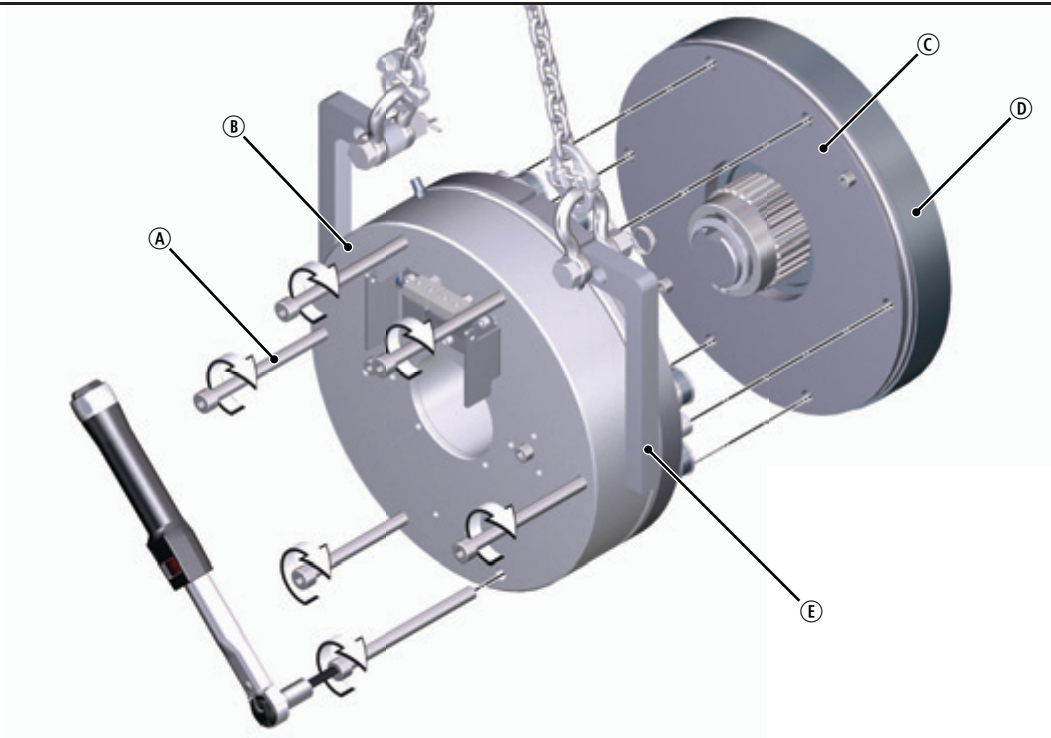

Fig. 12: Assembly of the stator

- | | | |
|--------------------------|--------------------------------|---------------------|
| Ⓐ Socket head cap screws | Ⓑ Stator | Ⓒ Flange (optional) |
| Ⓓ End shield | Ⓔ Lifting mechanism (optional) | |

2. Push the complete stator onto the shaft.
3. Evenly tighten the brake with the six socket head cap screws included in the scope of supply in several runs using a torque wrench.
4. Establish the electrical connection and energize the brake (siehe Chapter [Electrical connection](#), Page 38).

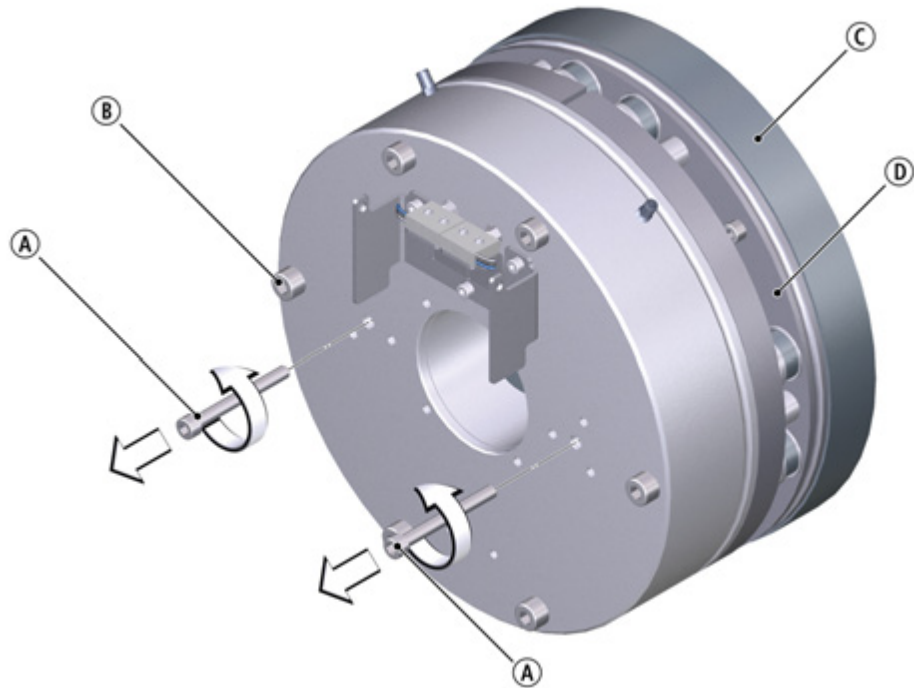



Fig. 13: Remove the safety bolts

- (A) Transport safety bolts (B) Socket head cap screws (C) End shield
(D) Flange (optional)

5. Remove the screws of the transport lock.
6. Use a torque wrench to retighten the supplied fastening screws with the required tightening torque, as shown in the table [Rated data for the screw set for brake mounting, Page 16](#).
7. Switch off the power.

Checking the air gap

	<p>⚠ DANGER</p>
	<p>Danger: rotating parts! Switch off the voltage. The brake must be free of residual torque.</p>

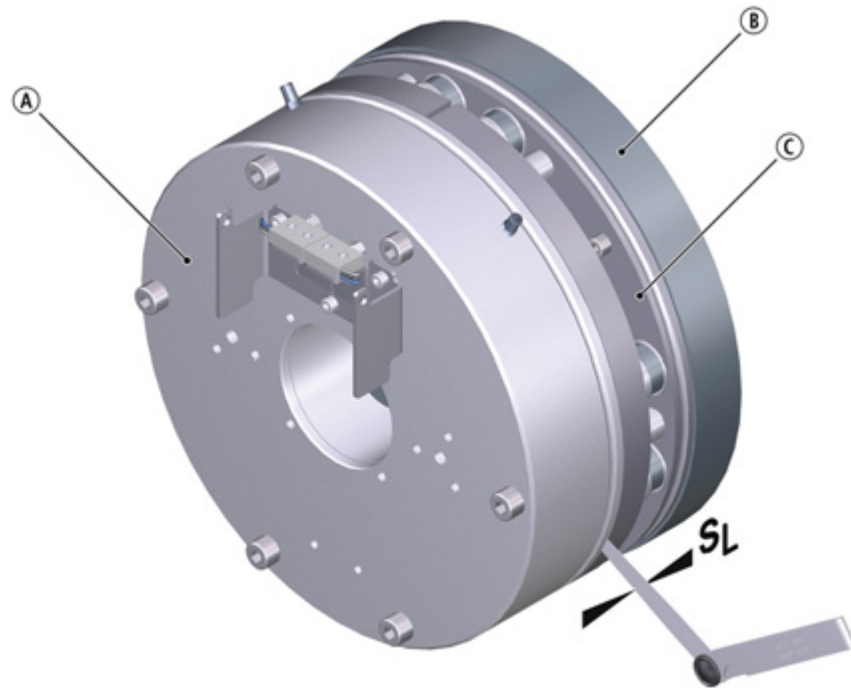

Fig. 14: Checking the air gap

8. Check the air gap near the screws by means of a feeler gage. Compare the measured values to the values for "s_{LN}" in the table [\(Rated data, Page 15\)](#).



Notice

Do not insert feeler gage more than 10 mm between armature plate and stator!



Notice

If the measured value for "s_L" is not within the tolerance, then the brake and the motor end shield must be checked!

5.7 Cover ring assembly

	NOTICE
Brakes without flange require a groove at the end shield for the lip of the cover ring.	

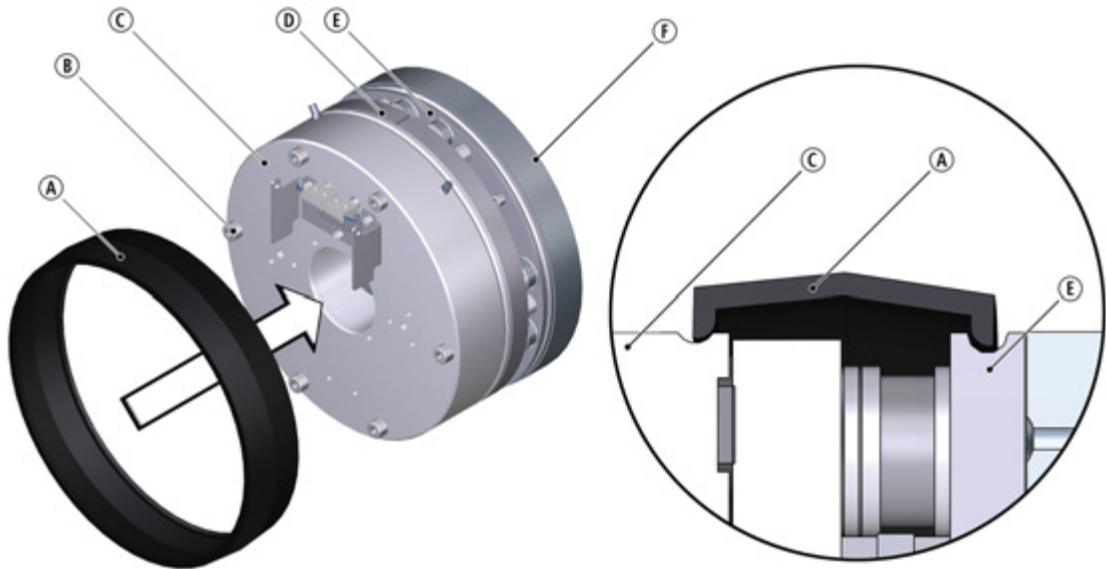



Fig. 15: Cover ring assembly

- | | | |
|------------------|--------------------------|--------------|
| Ⓐ Cover ring | Ⓑ Socket head cap screws | Ⓒ Stator |
| Ⓓ Armature plate | Ⓔ Flange (optional) | Ⓕ End shield |

1. Disconnect electrical connection.
2. Pull the cable through the cover ring.
3. Push the cover ring over the complete stator.
4. Press the lips of the cover ring into the groove of the complete stator and flange / end shield.
5. Re-establish the electrical connection.

	NOTICE
Cover ring with condensation drain hole: Attach the cover ring so that condensation can drain through the bore hole.	

5.8 Installing the hand-release (retrofitting)



Notice

The hand-release is mounted on the spring-applied brake which is already fitted on the motor. During this, the brake is not energized (except for steps 10 through 14). The brake's air gap is less than the maximum permissible value " S_{Lmax} ".

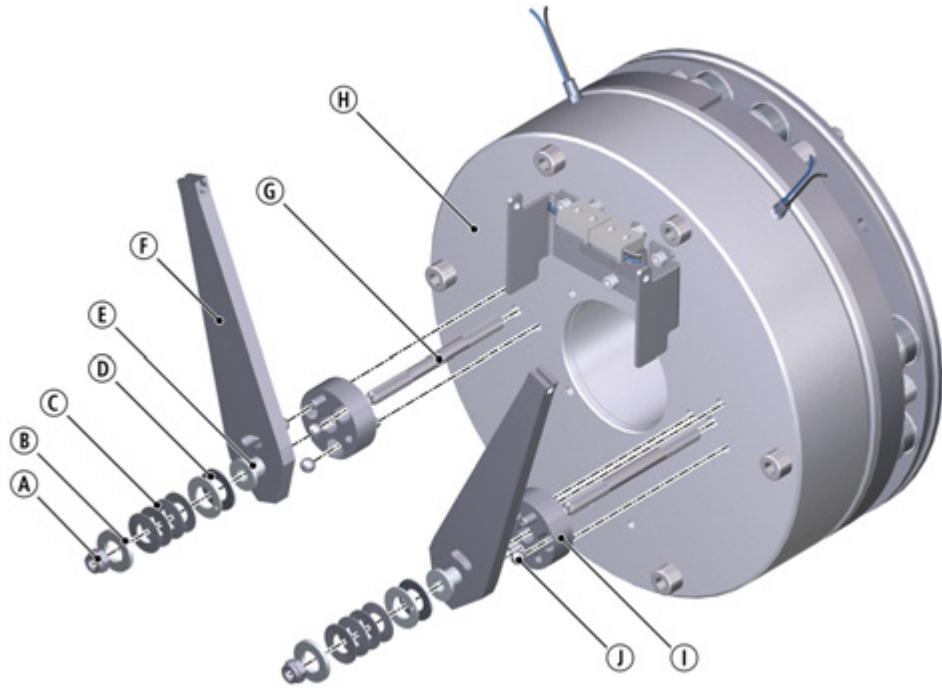

Fig. 16: Assembly of the hand-release BFK464-R

- | | | |
|-------------------|------------|---------------------|
| (A) Nut | (B) Washer | (C) Disk spring |
| (D) Thrust washer | (E) Sleeve | (F) Lever |
| (G) Stud bolt | (H) Stator | (I) Perforated disk |
| (J) Ball | | |

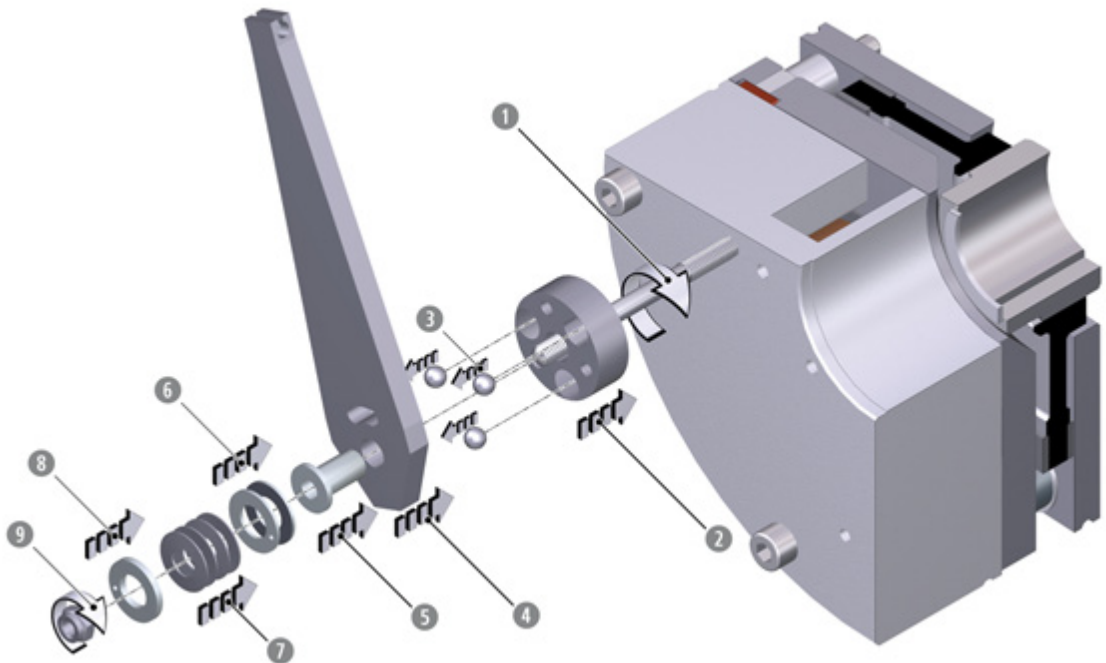

Fig. 17: Assembly of the hand-release BFK464-R

1. Insert two stud bolts (with the short threaded ends first) into the housing bore holes of the transport locking screws (which have already been removed). Use a suitable tool to tighten them with the following tightening torques:
10 Nm for sizes 17R and 18R, 20 Nm for sizes 19R and 20R, 40 Nm for sizes 22R and 25R or 70 Nm for size 28R.
2. Mount the disk with the three dowel pins into the bore holes on the brake. The protruding pins on the visible side of the disk must be oriented towards the cable outlet at the stator.
3. Insert the balls using some assembly paste into the bores of the lever.

**NOTICE**

Keep the friction lining free from grease and oil.

4. Put the lever (with the balls already inserted) onto the disk so it is concentric with the stud bolts. The dowel pin must protrude into the slot of the lever.
5. Insert the sleeves into the holes in the lever.
6. Place two thrust washers on the sleeve so that the lubricated coated sides face each other.
7. Place four disk springs in alternate directions in each of the thrust washers.
8. Place ring washers on the disk springs.
9. Screw the self-locking nuts onto the stud bolts and tighten them until they are flush against the ring washers.
10. Connect the brake to a suitable power supply and switch on the voltage (electrical release).
11. Tighten the nuts with the following tightening torques:
4 Nm for sizes 17R and 18R, 7 Nm for sizes 19R and 20R, 10 Nm for sizes 22R and 25R or 15 Nm for size 28R.
12. Turn the nuts back according to the corresponding degrees:
450° for sizes 17R and 18R, 360° for sizes 19R and 20R, 300° for sizes 22R and 25R or 260° for size 28R.
13. Check if a gap remains between the slot in the lever and the dowel pin while in this state (during hand-release).
14. Switch off the voltage.
15. Hook the Bowden cable onto the levers and operate the hand-release five times. Check the function of the hand-release mechanism (if the rotor can rotate). If necessary, repeat the configuration as described in steps 10 to 15.

**NOTICE**

Be sure to check the air gap "s_L" before adjusting the hand-release (siehe [Checking the air gap, Page 32](#)).

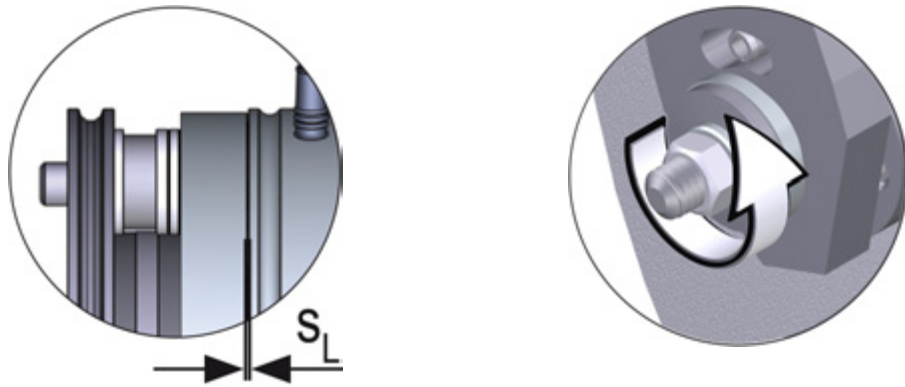



Fig. 18: Dimension "s_L"



Size	$s_{LN}^{+0.06/-0.08}$	Turn-back degrees
	[mm]	[°]
17R	0.4	450 (1 1/4 turn)
18R		
19R		360 (1 turn)
20R		
22R		
25R	300 (5/6 turn)	
28R	0.5	260 (7/10 turn)

Tab. 6: Turn-back degrees and air gap

	<p>⚠ DANGER</p>
	<p>The brake may fail. If the hand-release is incorrectly adjusted, the brake may fail and cause serious personal injury and damage to property. Protective measure: ■ Make sure that you comply with the specified turn-back degrees.</p>

6 Electrical installation

Important notes

	 DANGER
	<p>There is a risk of injury by electrical shock!</p> <ul style="list-style-type: none"> ■ The electrical connections may only be made by trained electricians! ■ Make sure that you switch off the electricity before working on the connections! There is a risk of unintended start-ups or electric shock.

	NOTICE
	<p>Make sure that the supply voltage matches the voltage specification on the name plate.</p>

	NOTICE
	<ul style="list-style-type: none"> ■ If an emergency stop is carried out without the required suppressor circuit, the control unit may be destroyed. ■ Observe the correct polarity of the suppressor circuit!

	NOTICE
	<ul style="list-style-type: none"> ■ To functionally test the individual brake circuits, the power supply must be able to be switched off individually. For a new over-energizing during switch-on, it is also necessary to open switches K1/K3. ■ The protective circuitry contained in the INTORQ switching device BEG-561- □□□-□□□ is not permitted for use in the lift technology. The protective circuitry must be connected in parallel to the brake coil (refer to the figure).

6.1 Electrical connection

Switching suggestions

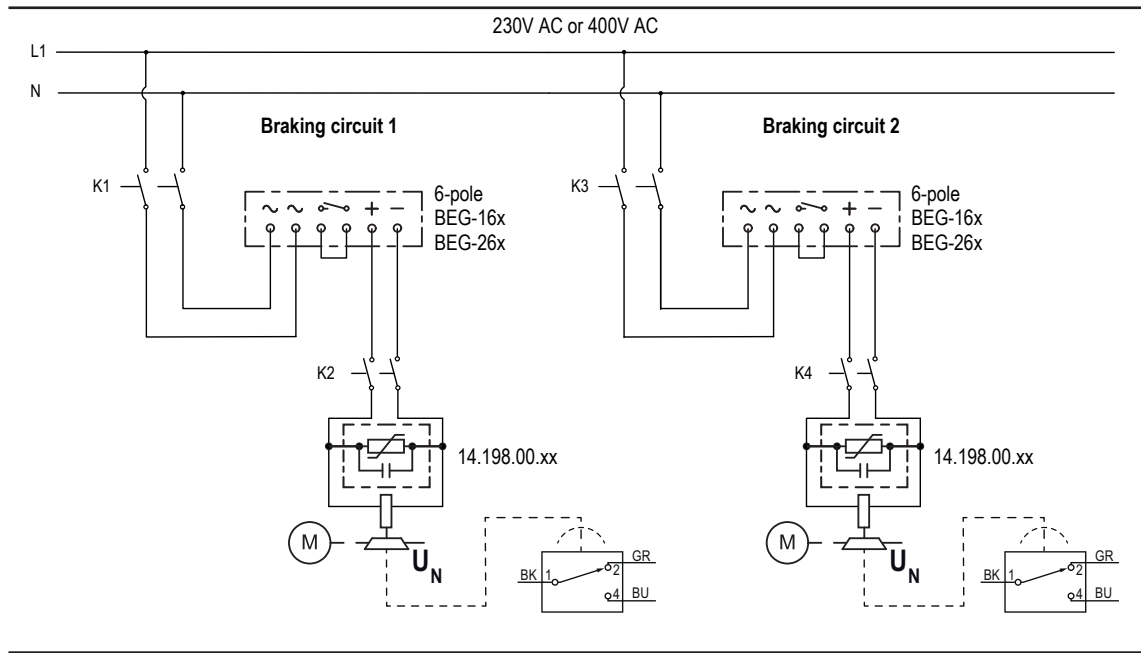

Fig. 19: Switching suggestion for the BFK464-R with holding current reduction

BK Black

GR Grey

BU Blue

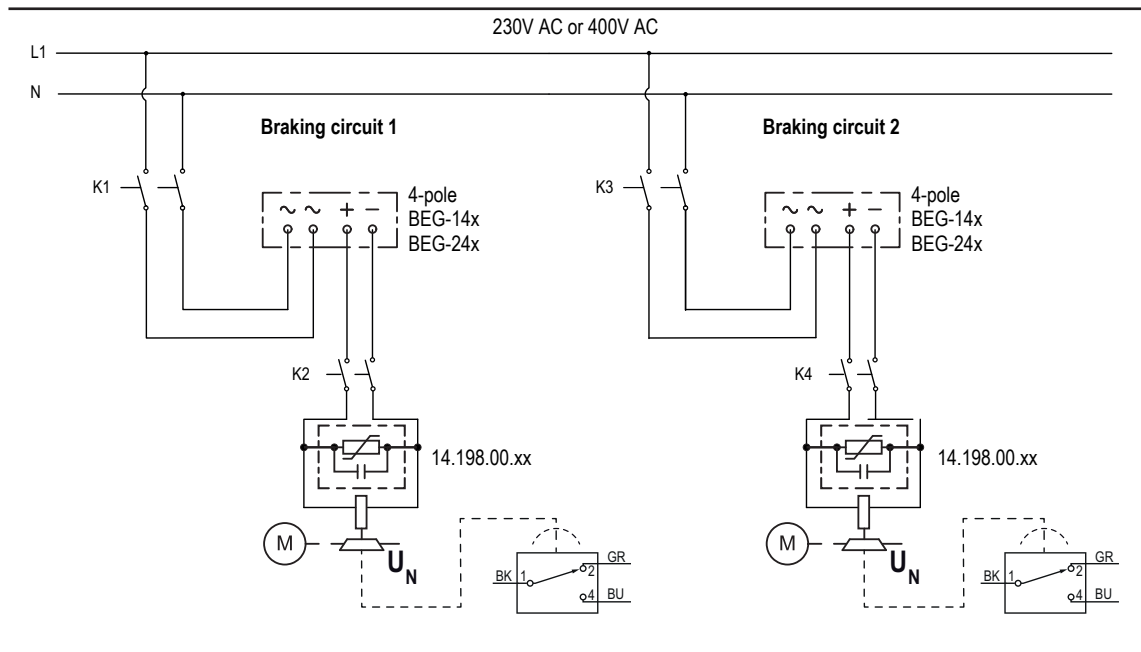

Fig. 20: Switching suggestion for the BFK464-R without holding current reduction

BK Black

GR Grey

BU Blue

Switching on

- K2/K4 must be switched on **before or at the same time** as K1/K3!

Switching off

- Normal - AC switching
 - K2/K4 remain closed
 - K1/K3 open
- Emergency stop - DC switching
 - K1/K3 and K2/K4 are opened at the same time



Notice

Recommended current load for the micro-switches

- DC current: 10 mA to 100 mA at 12 V
- AC current: 10 mA to 5 A at 12 V / max. 250 V
- Suppressor circuit: The limit voltage impacts the switching times (refer to the table Switching energy - operating frequency - operating times, Page 18).

6.2 Technical specifications for the micro-switch

The brake can be equipped with a micro-switch for monitoring the release or wear. The micro-switch can be integrated into the circuit as an NO or NC contact.

Design	Micro-switch
3-wire connecting cable	3 x 0.34 mm ² (AWG22) black / grey / blue UL file number 36479 Single wires, length 500 mm
Contacts	Silver
Current carrying capacity 250 V AC	Max. 3 A
Current carrying capacity 30 V DC	Max. 3 A
Minimum load at 24 V DC	10 mA
Temperature range:	-40 °C to +85 °C
Protection class	IP67

Tab. 7: Technical specifications for the micro-switch

	Switching states	$s_L = 0$	s_{LN}	$s_{Lmax} (-0.1)$
	Checking the air gap	1 - 4	1 - 2	1 - 2
	Monitoring wear	1 - 4	1 - 4	1 - 2

Tab. 8: Switching states of the mechanical micro-switches

6.3 Rectifier

6.3.1 Bridge-half-wave rectifier for brakes with holding voltage reduction

BEG-561-□□□-□□□

The bridge-half-wave rectifiers are used to supply electromagnetic DC spring-applied brakes which are approved for use with such rectifiers. Other use is only permitted with the approval of INTORQ.

Once a set over-excitation period has elapsed, the bridge-half-wave rectifiers switch over from bridge rectification to half-wave rectification.

Terminals 3 and 4 are located in the brake's DC circuit. When used in passenger elevators, these contacts must not be used to switch off the brake. Be sure to provide a protective circuit according to the "Switching suggestions" figures in the chapter [Electrical connection, Page 38](#).

6.3.2 Bridge rectifier for brakes without holding voltage reduction

BEG-142-270

The four-pole bridge rectifiers are used to supply electromagnetic DC spring-applied brakes which are approved for use with such rectifiers. Other use is only permitted with the approval of INTORQ.

6.3.3 Assignment: Rectifier - Brake size

Rectifier type	Supply voltage	Over-excitation		Holding current reduction	
	[V AC]	Coil voltage [V DC]	Size	Coil voltage [V DC]	Size
BEG-561-255-130	230	205	17R ... 28R	103	17R ... 28R
BEG-561-440-030-1	400	360	17R ... 28R	180	17R ... 28R
BEG-142-270	230	205	17R ... 28R	Without holding current reduction	

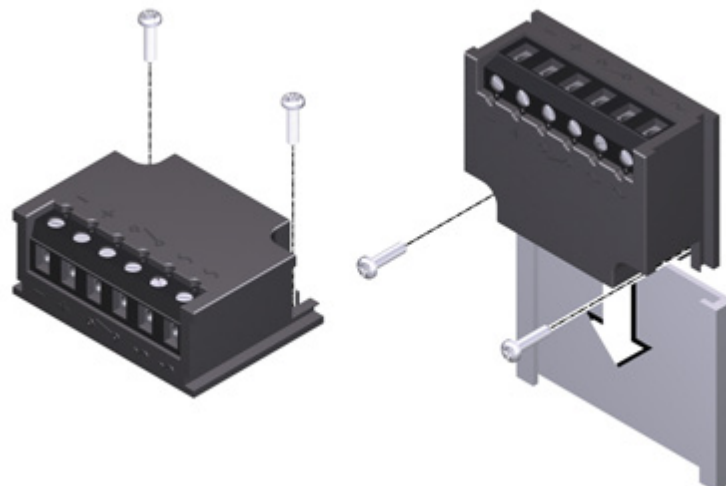

Fig. 21: BEG-561 fastening options

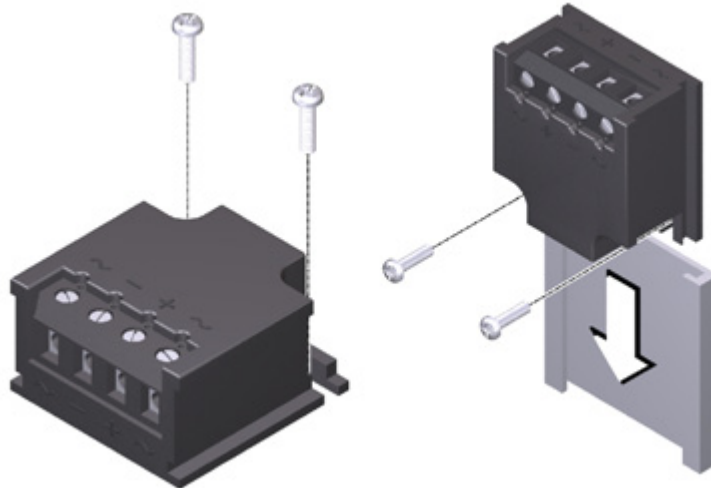

Fig. 22: BEG-142-270 fastening options

6.3.4 Technical specifications

Rectifier type	Bridge / half-wave rectifier	Bridge rectifiers
Output voltage for bridge rectification	$0.9 \times U_1$	$0.9 \times U_1$
Output voltage for half-wave rectification	$0.45 \times U_1$	without
Ambient temperature (storage/operation) [°C]	-25 – +70	-25 – +80

U_1 input voltage (40 – 60 Hz)

Type	Input voltage U_1 (40 Hz – 60 Hz)			Max. current I_{max}		Over-excitation period t_{ue} ($\pm 20\%$)		
	Min.	Rated	Max.	Bridge	half-wave	at U_{1min}	at U_{1Nom}	at U_{1max}
	[V~]	[V~]	[V~]	[A]	[A]	[s]	[s]	[s]
BEG-561-255-130	160	230	255	3.0	1.5	1,870	1,300	1,170
BEG-561-440-030-1	230	400	440	3.0	1.5	2,300	1,300	1,200
BEG-142-270	-	230	270	1.0	without	without	without	without

Tab. 9: Rectifier data

6.3.5 Permissible current load at ambient temperature

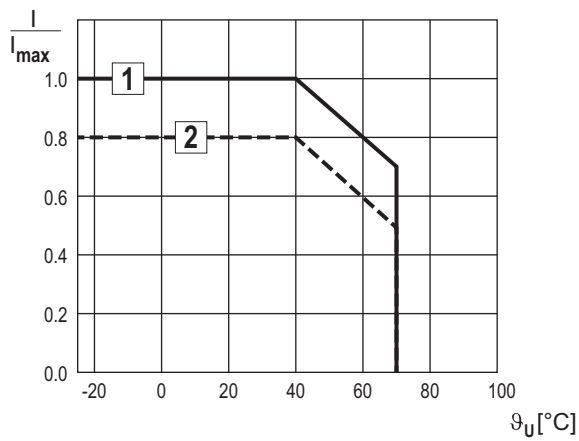

Fig. 23: Permissible current load for BEG-561-xxx-xxx

- ① If screwed to metal surface (good heat dissipation)
- ② For other installations (e.g. with adhesive)

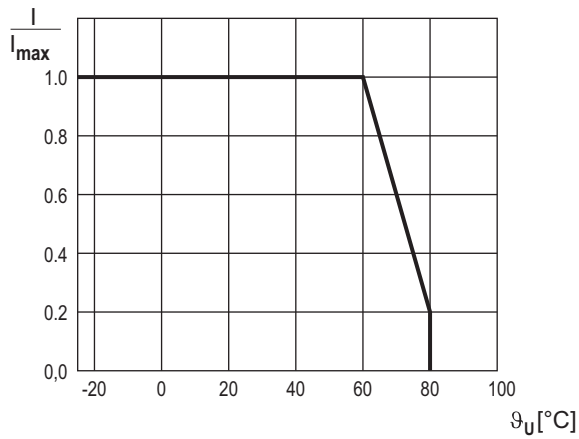





Fig. 24: Permissible current load for BEG-142-270

7 Commissioning and operation

Important notes

	 DANGER
	<p>Danger: rotating parts!</p> <ul style="list-style-type: none"> ■ The running rotor must not be touched. ■ Take structural design measures on your final product and implement organizational safety rules to ensure that nobody can touch a rotor.

	 DANGER
	<p>There is a risk of injury by electrical shock!</p> <p>The live connections must not be touched.</p>

- The brakes are dimensioned in such a way that the specified rated torques are reached safely after a short run-in period.
- Increased breakaway torque is common, in particular after long downtimes in humid environments where temperatures vary.
- Before the initial commissioning, check the braking torque when the brake is being used on the customer's friction surfaces.
- If the brake is used as a pure holding brake without any dynamic load, the friction lining must be reactivated regularly by implementing the friction work.

7.1 Function checks before initial commissioning

7.1.1 Brake with micro-switch

1. The switching contact for the brake must be open.
2. Remove two bridges from the motor terminals to de-energize the motor.
 - Do not switch off the voltage supply to the brake.

	NOTICE
	<p>If the brake is connected via the neutral point of the motor, this connection must also be used for connecting the neutral conductor.</p>

3. Apply DC voltage to the brake.
4. Measure the AC voltage at the motor terminals. The measured level must be zero.
5. Close the switching contact for the brake.
 - The brake is released.

6. Measure the DC voltage at the brake:
 - After the over-excitation time (refer to the table), the measured DC voltage must correspond to the holding voltage (refer to Assignment: Bridge/half-wave rectifier – brake size). A deviation of $\pm 10\%$ is permissible.
7. Check the air gap "s_L".
8. It must be zero and the rotor must rotate freely.
9. Check the switching status of the micro-switch (siehe to table [Switching status of micro-switch, Page 44](#)).
10. Open the switching contact for the brake.
 - The brake is applied.
11. Check the switching status of the micro-switch (siehe to table [Switching status of micro-switch, Page 44](#)).
12. Switch off DC voltage for the brake.
13. Screw the bridges onto the motor terminals.
14. If necessary, remove the neutral conductor from the neutral point (step 2).

Contact type	Connection	Brake released	Micro-switch closed
N/C contact	black / grey	yes	no
		no	yes
NO contact	black / blue	yes	yes
		no	no

Tab. 10: Switching status of micro-switch

The preparations for commissioning are completed.

7.1.2 Checking the hand-release



NOTICE

Labeling of drive systems and individual components

- The hand-release is designed for activation via a Bowden cable.
- An individual brake circuit can only be released electrically.

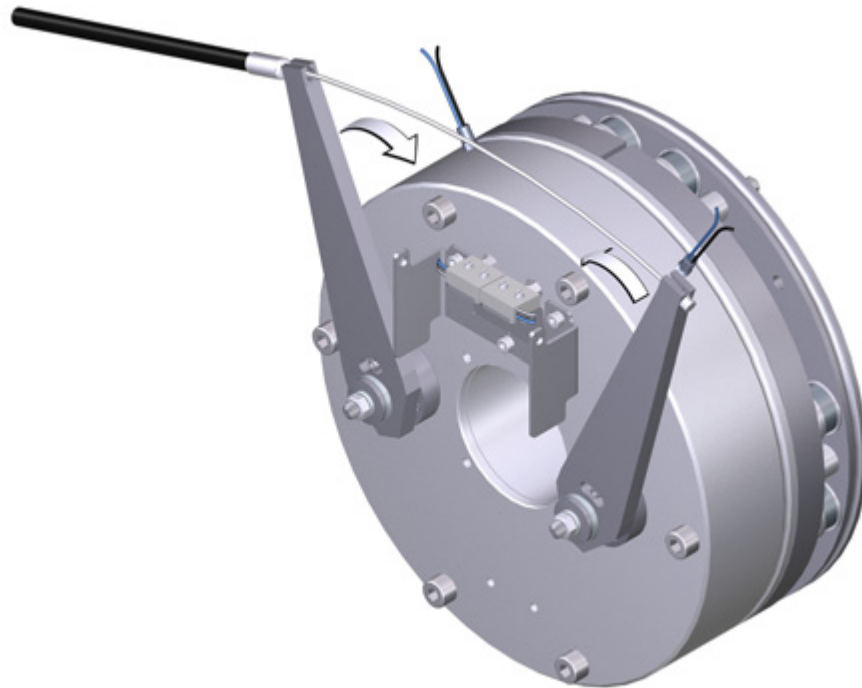

Fig. 25: Turning direction of the lever



		DANGER
	Danger: rotating parts! The motor must not be running when checking the hand-release.	

1. Hang the Bowden cable (not included in the scope of delivery) and tighten it using the torque required for that size (750 to 1100 newtons for size 17 to size 28).
 - The drive must be able to turn freely. A low residual torque is permitted.
2. Release the lever.
 - A torque must now be built up!

7.2 Commissioning

1. Switch on drive system.
2. Carry out a braking test.

7.3 During operation



	<p>⚠ DANGER</p> <p>Danger: rotating parts! The running rotor must not be touched.</p>
	<p>⚠ DANGER</p> <p>There is a risk of injury by electrical shock! The live connections must not be touched.</p>

- Checks must be carried out regularly. Pay special attention to:
 - unusual noises or temperatures
 - loose fixing elements
 - the condition of the electrical cables
- The armature plate must be tightened and the rotor must move without residual torque.
- Measure the DC voltage at the brake.
 - After the over-excitation time (refer to the table), the measured DC voltage must correspond to the holding voltage (refer to Assignment: Bridge/half-wave rectifier – brake size). A deviation of $\pm 10\%$ is permissible.
- If a fault occurs once, go through the troubleshooting table (siehe the chapter Troubleshooting and fault elimination). If the fault cannot be fixed or eliminated, please contact the customer service department.

8 Maintenance and repair

INTORQ spring-applied brakes are wear-resistant and designed for long maintenance intervals. The friction lining and braking mechanism are subject to operational wear. To ensure safe and trouble-free operations, the brake must be checked at regular intervals and replaced when necessary (refer to the table Maintenance intervals BFK458).

8.1 Wear of spring-applied brakes

	 WARNING
	<p>Braking torque reduction</p> <p>The system must not be allowed to continue operations after the maximum air gap s_{Lmax} has been exceeded. Exceeding the maximum air gap can cause a major reduction in the braking torque!</p>

The table below shows the different causes of wear and their impact on the components of the spring-applied brake. The influential factors must be quantified so that the service life of the rotor and brake can be calculated and so that the prescribed maintenance intervals can be specified accurately. The most important factors in this context are the applied friction work, the initial speed of rotation of braking and the operating frequency. If several of the causes of friction lining wear occur in an application at the same time, the effects should be added together when the amount of wear is calculated.

Component	Cause	Effect	Influencing factors
Friction lining	Braking during operation	Wear of the friction lining	Friction work
	Emergency stops		
	Overlapping wear during start and stop of drive		
	Active braking via the drive motor with support of brake (quick stop)		
	Starting wear in case of motor mounting position with vertical shaft, even when the brake is not applied		Number of start/stop cycles
Armature plate and flange	Rubbing and friction of the brake lining	Armature plate and flange are run in	Friction work
Gear teeth of brake rotor	Relative movements and shocks between brake rotor and brake hub / toothed shaft	Wear of gear teeth (primarily on the rotor side)	Number of start/stop cycles
Brake support	Load reversals and jerks in the backlash between the armature plate and guide pins	Breaking of armature plate and guide pins	Number of start/stop cycles, braking torque
Springs	Axial load cycle and shear stress of springs through radial backlash on reversal of armature plate	Reduced spring force or fatigue failure	Number of switching operations of brake

Tab. 11: Causes for wear

8.2 Inspections

To ensure safe and trouble-free operations, the spring-applied brakes must be checked at regular intervals and, if necessary, replaced. Servicing at the facility will be easier if the brakes are made accessible. This must be considered when installing the drives in the plant.

Primarily, the required maintenance intervals for industrial brakes result from their load during operation. When calculating the maintenance interval, all causes for wear must be taken into account. (Refer to the table Causes for wear). For brakes with low loads (such as holding brakes with emergency stop function), we recommend a regular inspection at a fixed time interval. To reduce costs, the inspection can be carried out along with other regular maintenance work in the plant.

Failures, production losses or damage to the system may occur when the brakes are not serviced. Therefore, a maintenance strategy that is adapted to the particular operating conditions and brake loads must be defined for every application. For the spring-applied brakes, the maintenance intervals and maintenance operations listed in the table below must be followed. The maintenance operations must be carried out as described in the detailed descriptions.

8.2.1 Maintenance intervals

Versions	Operating brakes	Holding brakes with emergency stop
BFK464-R	<ul style="list-style-type: none"> ■ according to the service life calculation 	<ul style="list-style-type: none"> ■ at least every 2 years
	<ul style="list-style-type: none"> ■ or else every six months 	<ul style="list-style-type: none"> ■ after 1 million cycles at the latest
	<ul style="list-style-type: none"> ■ after 4000 operating hours at the latest 	<ul style="list-style-type: none"> ■ Plan shorter intervals for frequent emergency stops.

8.3 Maintenance



Notice



Brakes with defective armature plates, springs or flanges must be completely replaced. Observe the following for inspections and maintenance works:

- Contamination by oils and greases should be removed using brake cleaner, or the brake should be replaced after determining the cause. Dirt and particles in the air gap between the stator and the armature plate endanger the function and should be removed.
- After replacing the rotor, the original braking torque will not be reached until the run-in operation for the friction surfaces has been completed. After replacing the rotor, the run-in armature plates and the flanges have an increased initial rate of wear.

8.3.1 Checking the components



With mounted brake	■ Check release function and control	Refer to <u>Release / voltage, Page 50</u>
	■ Measure the air gap	
	■ Measure the rotor thickness (replace rotor if required)	Refer to <u>Check the rotor thickness, Page 49</u>
	■ Thermal damage of armature plate or flange (dark-blue tarnishing)	
After removing the brake	■ Check the play of the rotor gear teeth (replace worn-out rotors)	Refer to <u>Replace rotor, Page 51</u>
	■ Check for breaking out of the torque support at the guide parts and the armature plate	
	■ Check the springs for damage	
	■ Check the armature plate and flange or end shield <ul style="list-style-type: none"> - Flatness depending on the size - Max. run-in depth = rated air gap for the size 	Refer to the End shield as counter-friction surface: Table table. Refer to the Rated data for air gap specifications table.

8.3.2 Check the rotor thickness

	 DANGER
	<p>Danger: rotating parts!</p> <p>The motor must not be running when checking the rotor thickness.</p>



1. Remove the fan cover.
2. Remove the cover ring, when present.
3. Measure the rotor thickness using a caliper gage. For the friction-plate design: observe the edging on outer diameter of friction plate.
4. Compare the measured rotor thickness with the minimum permissible rotor thickness. (Refer to the values in the table Rated data for air gap specifications.) If the measured rotor thickness is insufficient, the rotor must be replaced completely. (Refer to Replace rotor for the description.)

8.3.3 Checking the air gap

	 DANGER
	Danger: rotating parts! The motor must not run while the air gap is being checked.



1. Measure the air gap s_L between the armature plate and the stator near the fastening screws using a feeler gauge. (Refer to table Rated data for air gap specifications for the values.)
2. Compare the measured air gap to the value for the max. permissible air gap s_{Lmax} . (Refer to table Rated data for air gap specifications for the values.)
3. If required, replace both rotors completely ([Replace rotor, Page 51](#)).

8.3.4 Release / voltage

	 DANGER
	Danger: rotating parts! The running rotor must not be touched.

1. Check the brake functionality when the drive is running: The armature plate must be tightened and the rotor must move without residual torque.
2. Measure the DC voltage at the brake.
 - Compare the measured voltage to the voltage specified on the name plate. A deviation of up to 10% is permitted.
 - When using bridge/half-wave rectifiers: After switching to one-way voltage, the measured DC voltage may drop to 45% of the voltage specified on the name plate.

8.3.5 Replace rotor

	 DANGER
	<p>Danger: rotating parts!</p> <p>Switch off the voltage. The brake must be free of residual torque. Your system should be mechanically immobilized in the event that it could start moving when the brake is released.</p>

1. Remove the connection cables.
2. Loosen the screws evenly and then remove them.
3. Pay attention to the connection cable during this step! Remove the complete stator from the end shield.
4. Check the armature plate's friction surface. Replace the complete stator when there is clearly visible scoring at the running surface.
5. Pull the rotor off the hub.
6. Check the hub's gear teeth.
7. Replace the hub if wear is visible.
8. Check the end shield's friction surface. Replace the friction surface on the end shield when there is clearly visible scoring at the running surface.
9. You can now install and adjust the new rotor and the complete stator. (Refer to Brake mounting, Page 29.)
10. Re-connect the connection cables.
11. If necessary, deactivate the mechanical shutdown of the system.

8.4 Spare parts list

- Only parts with item numbers are available.
 - The item numbers are only valid for the standard design.
- Please include the following information with the order:
 - Order number of the brake
 - Position number of the spare part

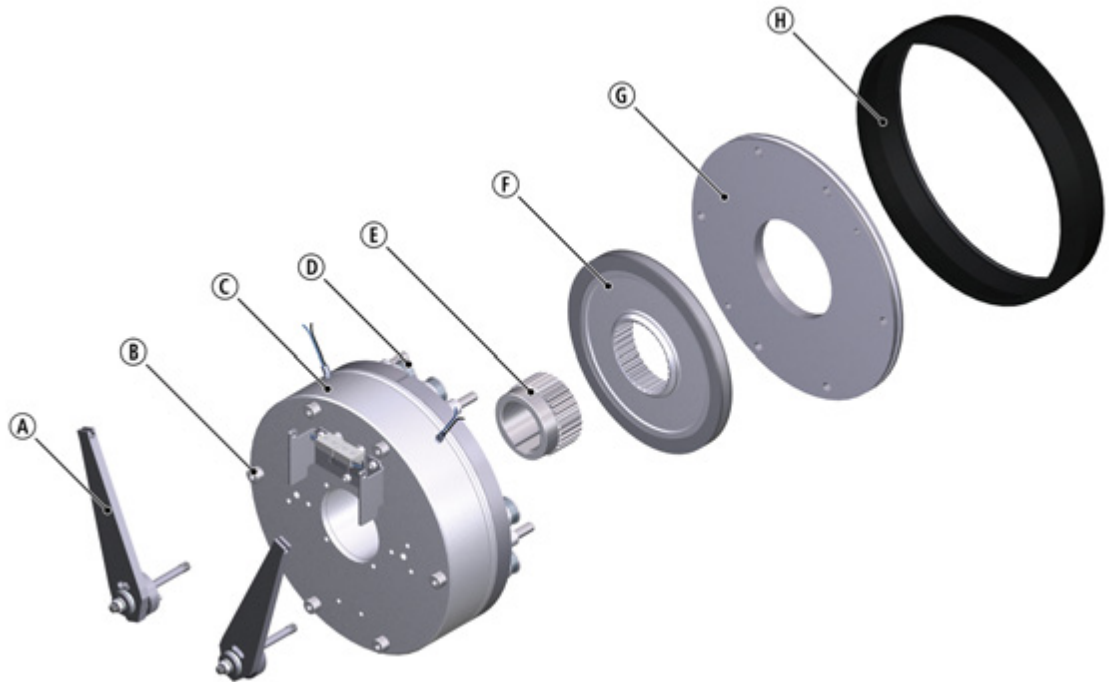

Fig. 26: Spring-applied brake 464-□□R

	Designation	Variant
Ⓐ	Complete hand-release	
Ⓑ	Fastening screws Fastening screws	<ul style="list-style-type: none"> ■ for mounting to the flange with through-holes ■ for mounting to the motor
Ⓒ	Complete stator	<ul style="list-style-type: none"> ■ Voltage ■ Rated torques
Ⓓ	Noise reducer	
Ⓔ	Hub	
Ⓕ	Complete rotor	<ul style="list-style-type: none"> ■ For brake with hub ■ For directly toothed shaft
Ⓖ	Flange	
Ⓗ	Cover ring	

9 Troubleshooting and fault elimination





If any malfunctions should occur during operations, please check for possible causes based on the following table. If the fault cannot be fixed or eliminated by one of the listed steps, please contact customer service.

Fault	Cause	Remedy
Brake does not release	Coil interruption	<ul style="list-style-type: none"> ■ Measure coil resistance using a multimeter: <ul style="list-style-type: none"> – If resistance is too high, replace the complete stator.
	Coil has contact to earth or between windings	<ul style="list-style-type: none"> ■ Measure coil resistance using a multimeter: <ul style="list-style-type: none"> – Compare the measured resistance with the nominal resistance. Refer to Rated data for coil powers for the values. If resistance is too low, replace the complete stator. ■ Check the coil for short to ground using a multimeter: <ul style="list-style-type: none"> – If there is a short to ground, replace the complete spring-applied brake. ■ Check the brake voltage (refer to section on defective rectifier, voltage too low).
	Wiring defective or wrong	<p>Check the wiring and correct.</p> <ul style="list-style-type: none"> ■ Check the cable for continuity using a multimeter <ul style="list-style-type: none"> – Replace a defective cable.
	Rectifier defective or incorrect	<ul style="list-style-type: none"> ■ Measure rectifier DC voltage using a multimeter. ■ If DC voltage is zero: <ul style="list-style-type: none"> ■ Check AC rectifier voltage. ■ If AC voltage is zero: <ul style="list-style-type: none"> – Switch on power supply – Check fuse – Check wiring. ■ If AC voltage is okay: <ul style="list-style-type: none"> – Check rectifier, – Replace defective rectifier ■ Check coil for inter-turn fault or short circuit to ground. ■ If the rectifier defect occurs again, replace the entire spring-applied brake, even if you cannot find any fault between turns or short circuit to ground. The error may only occur on warming up.

Fault	Cause	Remedy
Brake does not release	Incorrect micro-switch wiring	Check the wiring of the micro-switch and correct it.
	Micro-switch incorrectly set	Replace the complete stator and make a complaint about the setting of the micro-switch to the manufacturer.
	Air gap "s _L " is too large	<ul style="list-style-type: none"> ■ For non-adjustable brakes: <ul style="list-style-type: none"> – Replace rotor. Refer to Replace rotor, Page 51.
Rotor cannot rotate freely	Air gap "s _L " too small	Check the air gap "s _L ".
Rotor is too thin	Rotor has not been replaced in time	Replace rotor. Refer to Replace rotor, Page 51 .
The voltage is not zero during the functional test (refer to the chapter Function checks before initial commissioning, Page 43).	Incorrect micro-switch wiring	Check and correct the wiring of the micro-switch.
	Micro-switch defective or incorrectly set	Replace the complete stator and return the defective complete stator to the manufacturer.
Voltage too high	Brake voltage does not match the rectifier	Adjust rectifier and brake voltage to each other.
Voltage too low	Brake voltage does not match the rectifier	Adjust rectifier and brake voltage to each other.
	Defective rectifier diode	Replace the defective rectifier with a suitable undamaged one.
AC voltage is not mains voltage	Fuse is missing or defective	Select a connection with proper fusing.
	Incorrect micro-switch wiring	Check and correct the wiring of the micro-switch.
	Micro-switch defective or incorrectly set	Replace the complete stator and return the defective complete stator to the manufacturer.

 INTORQ GmbH & Co KG
Germany
PO Box 1103
D-31849 Aerzen, Germany
Wülmser Weg 5
D-31855 Aerzen, Germany
 +49 5154 70534-0 (Headquarters)
 +49 5154 70534-222 (Sales)
 +49 5154 70534-200
 info@intorq.com

 应拓柯制动器 (上海) 有限责任公司
INTORQ (Shanghai) Co., Ltd.
上海市浦东新区泥城镇新元南路600
号6号楼一楼B座
No. 600, Xin Yuan Nan Road,
Building No. 6 / Zone B
Nicheng town, Pudong
201306 Shanghai
 +86 21 20363-810
 +86 21 20363-805
 info@cn.intorq.com

 INTORQ US Inc.
USA
300 Lake Ridge Drive SE
Smyrna, GA 30082, USA
 +1 678 236-0555
 +1 678 309-1157
 info@us.intorq.com

 INTORQ India Private Limited
India
Plot No E-7/3
Chakan Industrial Area, Phase 3
Nighoje, Taluka - Khed
Pune, 410501, Maharashtra
 +91 2135625500
 info@intorq.in